

3655341EBL Single Door Wardrobe

Ameriwood
HOME

Date of Purchase ___ / ___ / ___
Lot Number:

B343655341EBL0

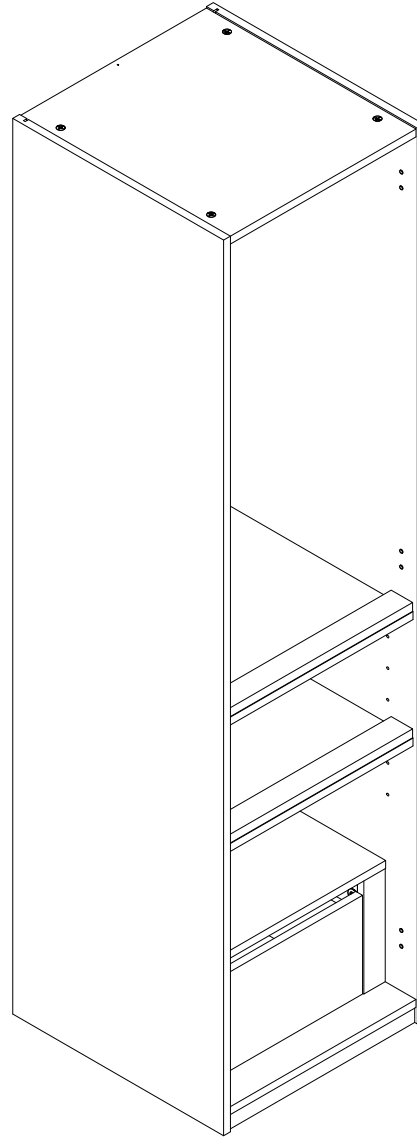

THIS INSTRUCTION BOOKLET CONTAINS **IMPORTANT** SAFETY INFORMATION. PLEASE READ AND KEEP FOR FUTURE REFERENCE.

Do Not Return This Product!

Contact our customer service team for help first.

Call: 1-800-489-3351 (toll free)

Visit: www.ameriwoodhome.com



WARNING

- Unit can tip over causing severe injury or death.
- Anchor unit to stud in wall (if instructed to).
- Do Not allow children to climb on unit.
- Put heavy items on lower shelves or drawers.

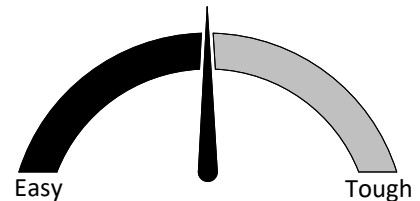

Assembly Difficulty Meter

Follow Ameriwood Home



Contact Us!

Do NOT return this product!

Contact our friendly customer service team first for help.

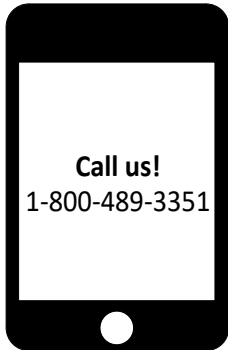

Visit ameriwoodhome.com to view the limited warranty valid in the U.S. and Canada.

Assembly Tips



Helpful Hints

PEOPLE NEEDED FOR ASSEMBLY: 1-2

- Open your item in the area you plan to keep it to avoid excessive heavy lifting.
- Identify, sort and count the parts before attempting assembly.
- Compression dowels are lightly tapped in with a hammer.
- Slides are labeled with a **R** (right) and **L** (left) for proper placement.
- Make sure to always face the point on the top of the Cam Lock towards the outer edge.
- Use all the nails provided for the back panel and spread them out equally.
- Back panel must be used to make sure your unit is sturdy.
- Do NOT use harsh chemicals or abrasive cleaners on this item.
- Never push, pull, or drag your furniture.

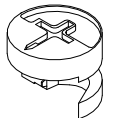

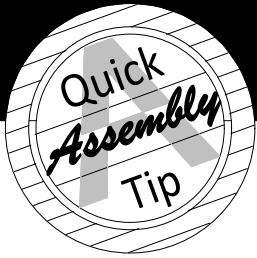

Before You Start

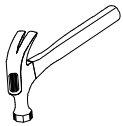
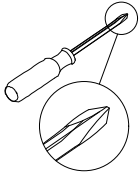

- ✓ Read through each step carefully and follow the proper order
 - ✓ Separate and count all your parts and hardware
Parts are labeled on the surface or edge of the part
 - ✓ Give yourself enough room for the assembly process
 - ✓ Have the following tools: #2 Phillips Head Screwdriver and Hammer
- Caution: If using a power drill or power screwdriver for screwing, please be aware to slow down and stop when screw is tight. Reduce torque setting to a lower level so the drill will skip when the screw is tight. Failure to do so may result in stripping the screw.

Cam Lock Fastening System

This Cam Lock Fastening System will be used throughout the assembly process.

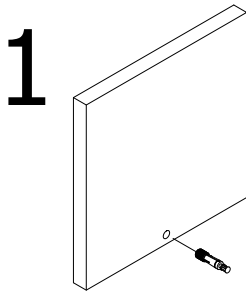

1 Press CAM BOLT into hole.

2

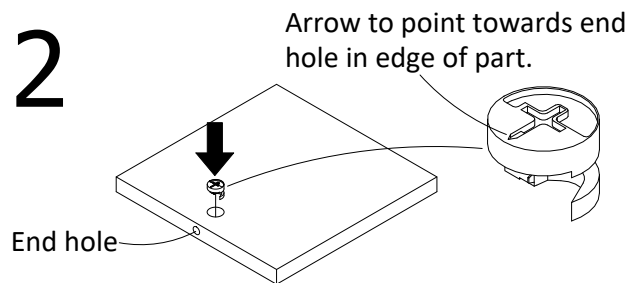

Press CAM LOCK into hole.

3

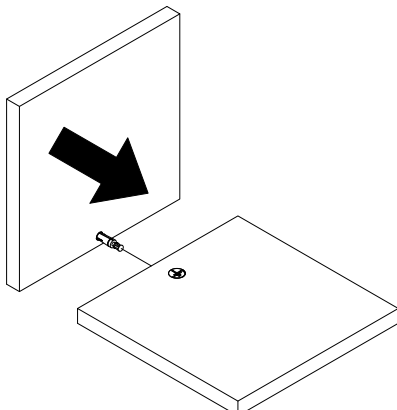

Press parts together so CAM BOLT inserts into edge hole.

4

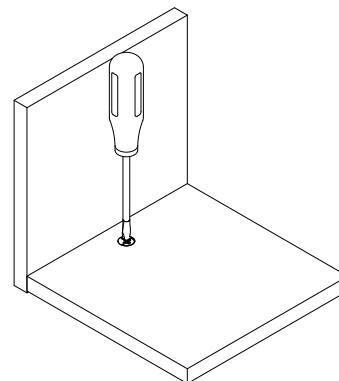

Using a screwdriver, turn the CAM LOCK clockwise to lock the CAM LOCK and CAM BOLT into their holes and fastening parts together.

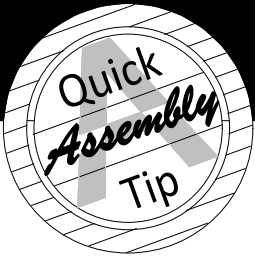

Before You Start

Please Note:

You may need to lightly tap the wood dowels into the holes during your assembly process.

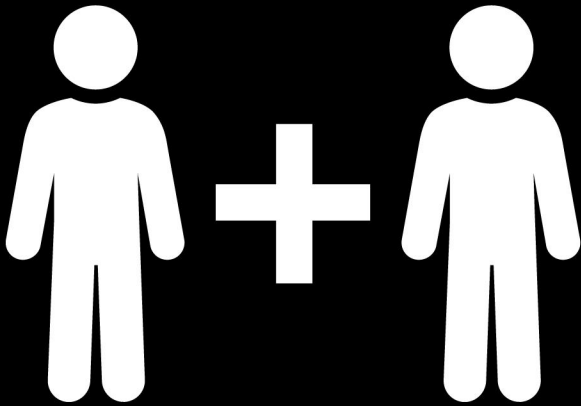
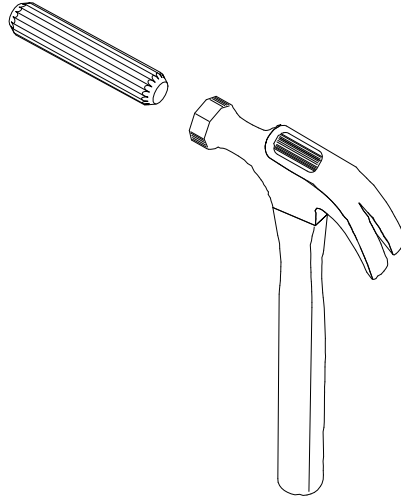

2 PEOPLE NEEDED FOR ASSEMBLY

**2 PERSONAS NECESITADAS
PARA LA ASAMBLEA**

**2 PERSONNES NÉCESSAIRES
POUR L'ASSEMBLAGE**

CAUTION: Failure to use 2 people for assembly could result in unit damage or personal injury.

PRECAUCIÓN: Si no se utilizan 2 personas para el ensamblaje, se pueden producir daños en la unidad o lesiones personales.

ATTENTION: Échec d'utiliser 2 personnes pour l'assemblage peut causer du dommage au meuble ou causer des blessures.

Board Identification

Not actual size

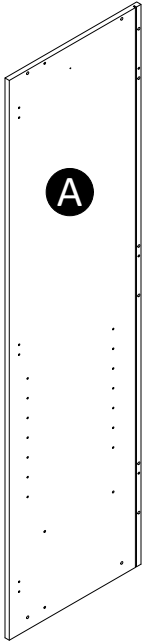

Left Side Panel
33655341010

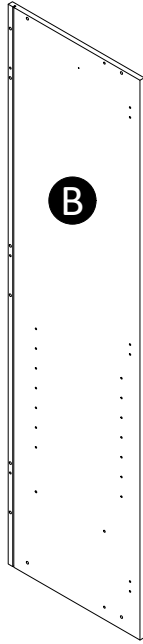

Right Side Panel
33655341020

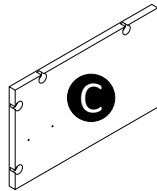

Left Inner Upright
33655341030

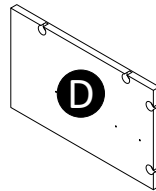

Right Inner Upright
33655341040

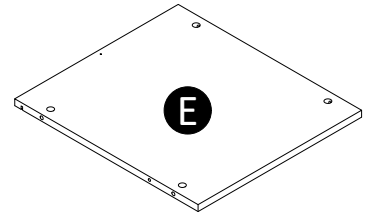

Top
33655341050

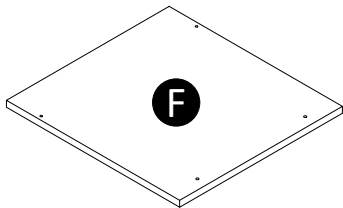

Adjustable Shelf (x2)
33655341060

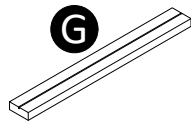

Adj Shelf Rail (x2)
33655341070

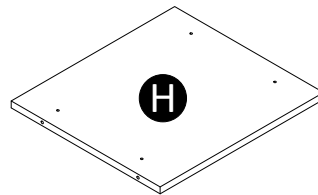

Fixed Shelf
33655341080

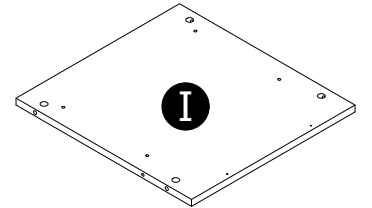

Bottom
33655341090

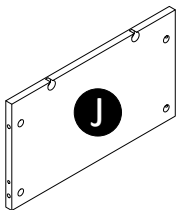

Rear Top Stringer
33655000100

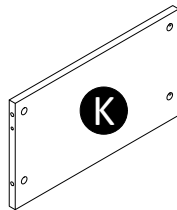

Rear Lower Stringer (x2)
33655000110

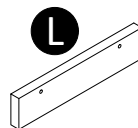

Vertical Rail (x2)
33655341120

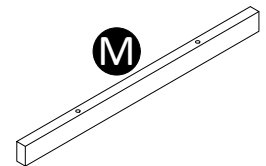

Kick
33655341130

Board Identification

Not actual size

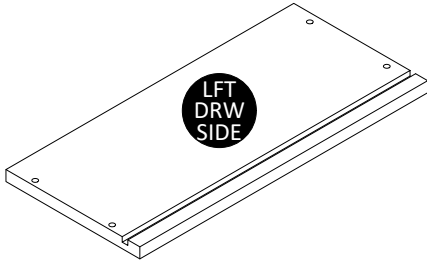

Drawer Side Left
39991167359430L

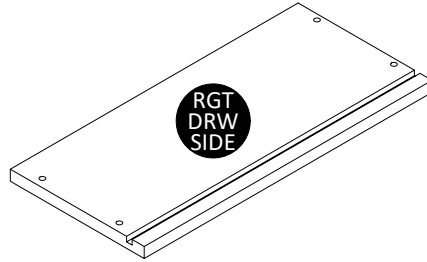

Drawer Side Right
39991167359430R

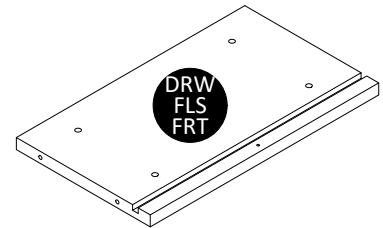

Drawer False Front
39991167028519F



Drawer Back
39991167028519B

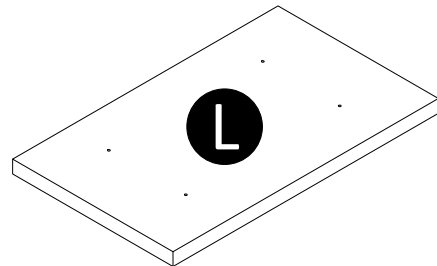

Drawer Front
33655341140

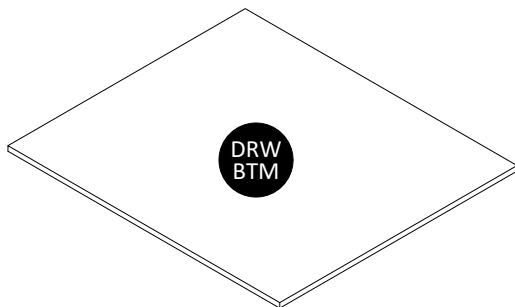

Drawer Bottom
39991339029620D

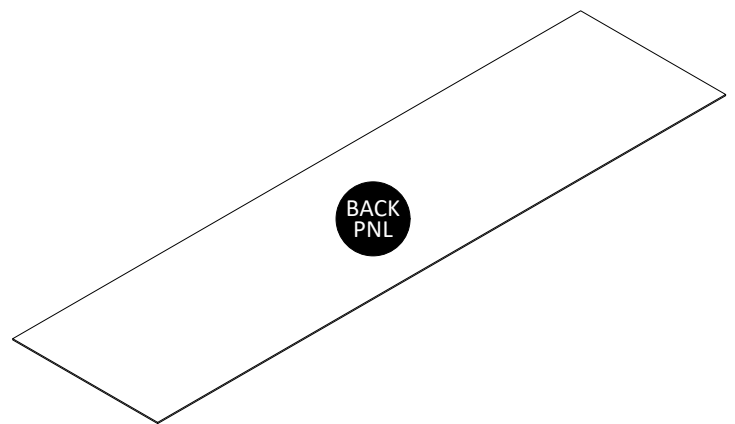

Back Panel
K365534100

Board Identification

Not actual size

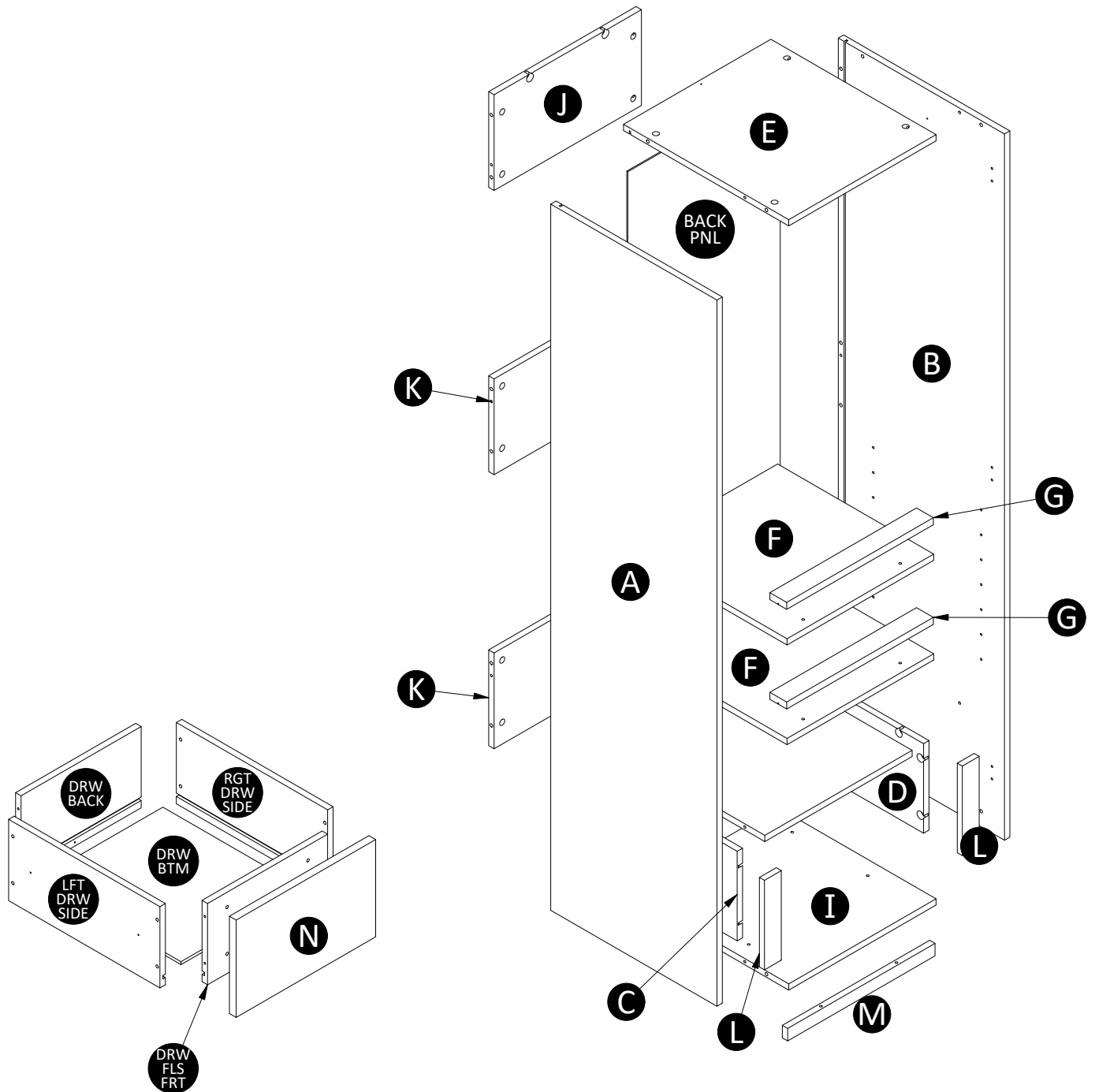

Note: Your unit may contain extra hardware.

Part List

Actual Size

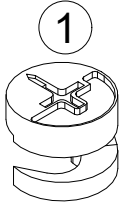

(x24)
#A22700
cam lock

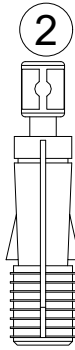

(x24)
#A22710
cam bolt

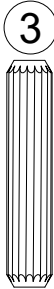

(x14)
#A21670
wood dowel

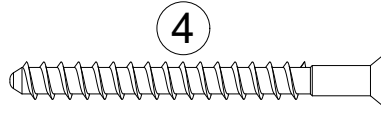

(x4)
#A23030
confirmat screw

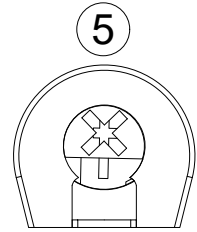

(x10)
#A22900
connector housing

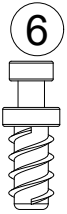

(x10)
#A22910
connector bolt

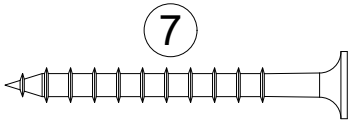

(x2)
#A13410
1-3/4" screw

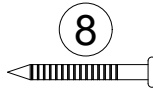

(x4)
#A21110
nail

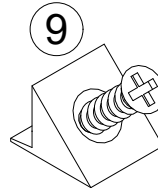

(x8)
#A54710
wedge

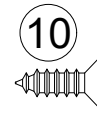

(x2)
#A11080
7/16" screw

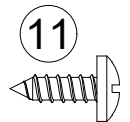

(x20)
#A12120
7/16" screw



(x12)
#A24930
hole plug

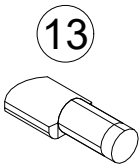

(x8)
#A80250
shelf support

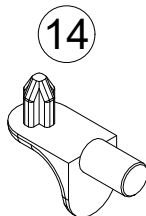

(x4)
#A80480
shelf support

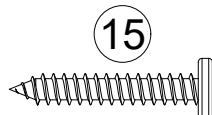

(x8)
#A12810
1" screw

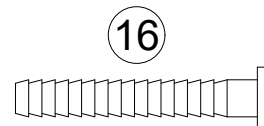

(x8)
#A21975
drive fastener

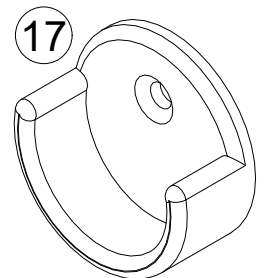

(x2)
#A82010
rod bracket

Note: Your unit may contain extra hardware.

Part List

Not Actual Size

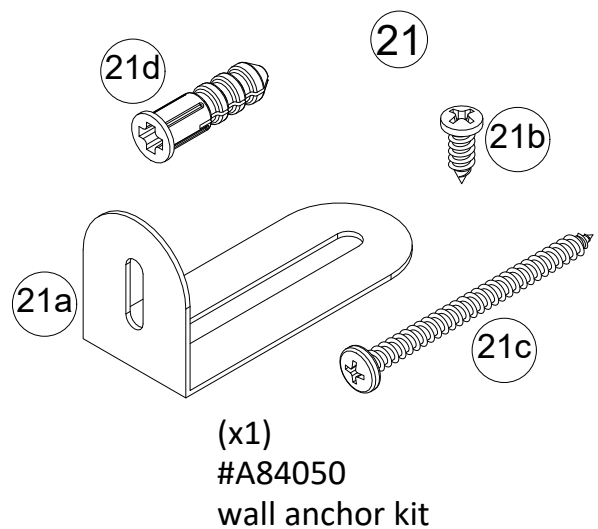
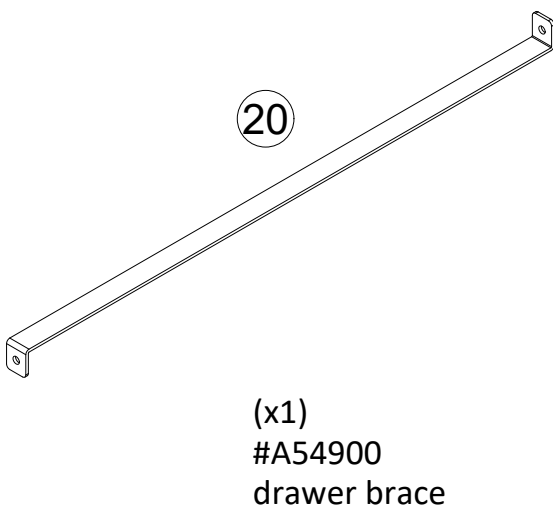
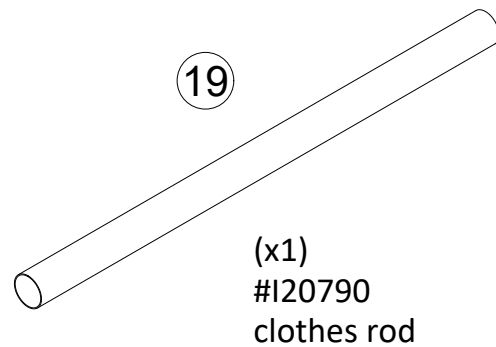
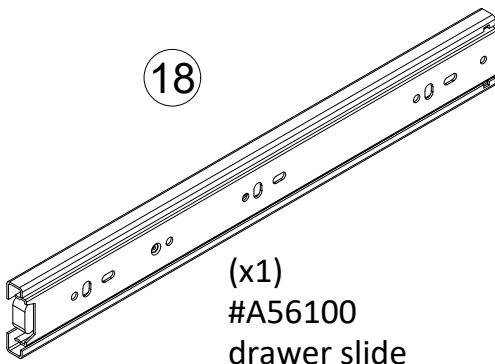

Part List

Slide Information

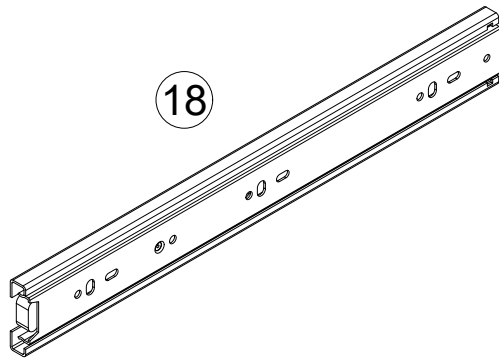

Your unit comes with four (2) drawer slides. For each slide, extend the slide as shown and press the release lever to remove the inner slide. Set the inner slide aside for later. For Step 3 and 4, you will be attaching the slide to the panels at the rear of the slide. While sliding the middle slide, locate the holes in the panels with the access holes in the middle slide and fasten with screws.

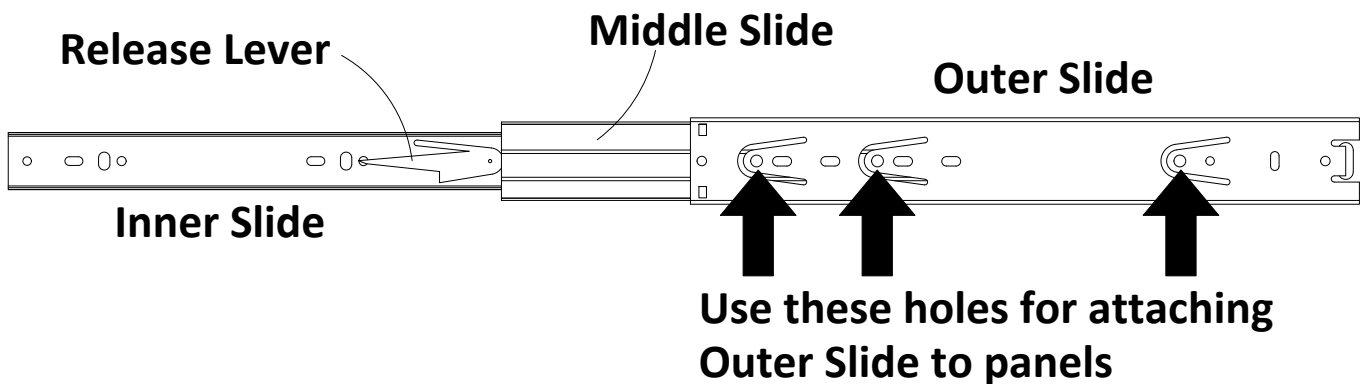

STEP 1

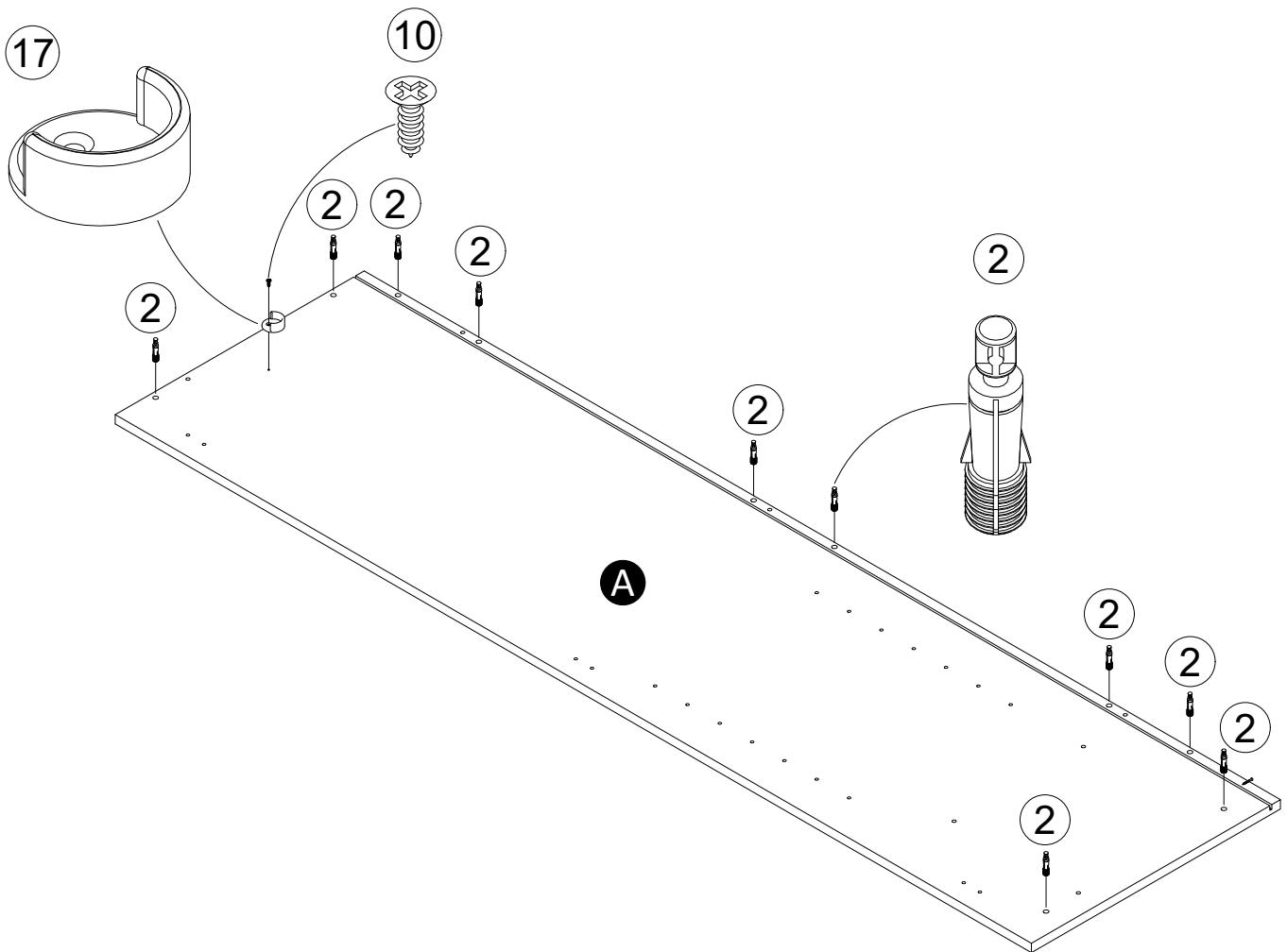
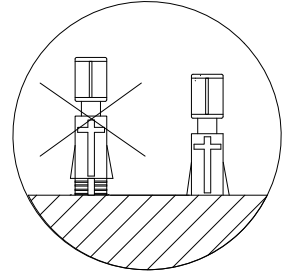
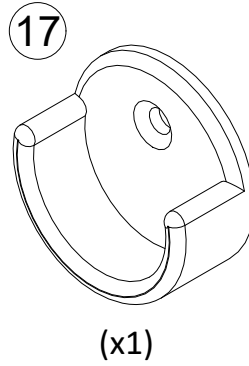
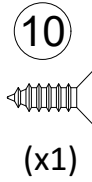
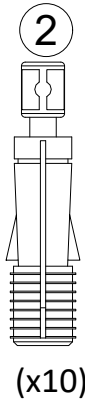
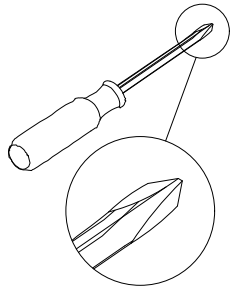

STEP 2

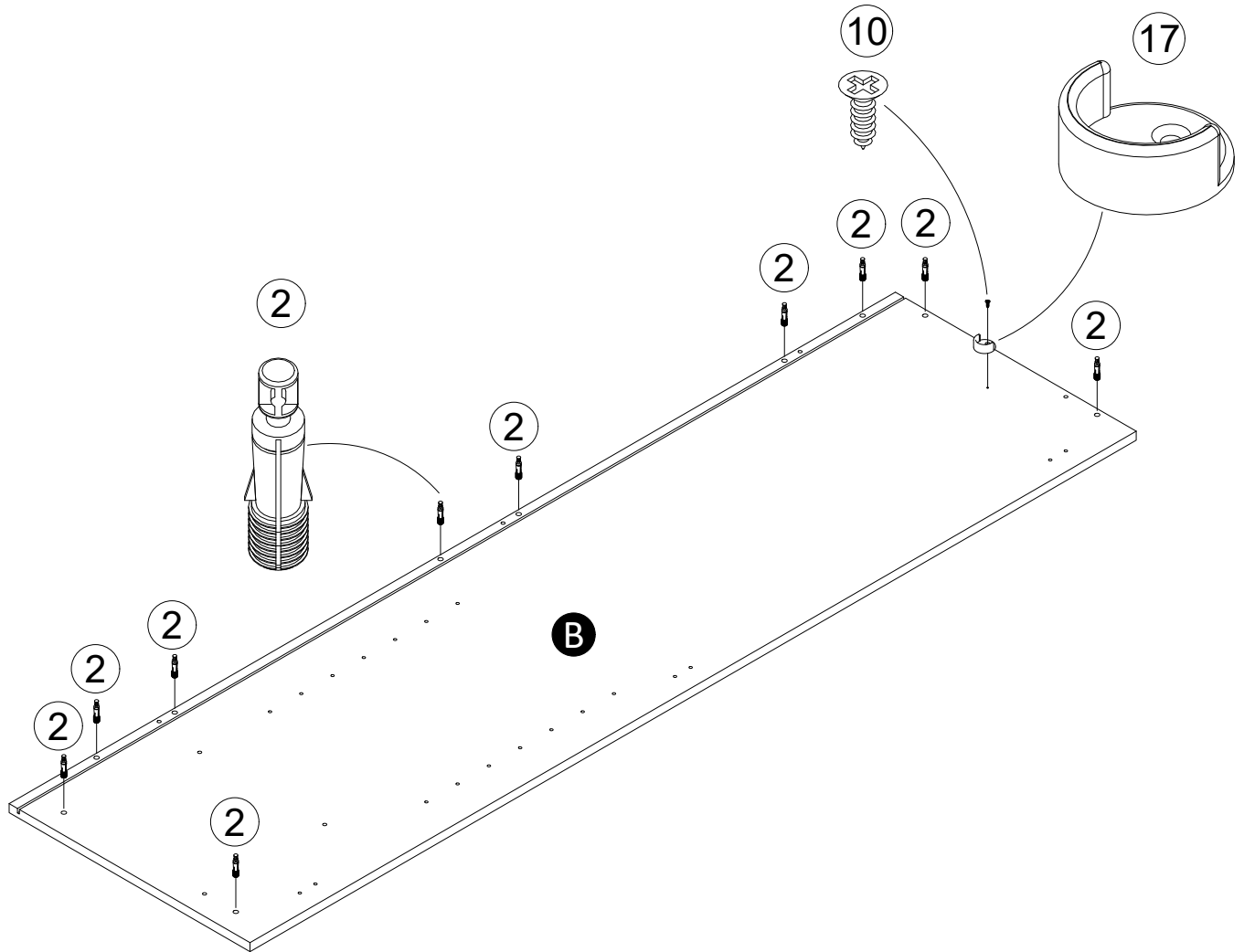
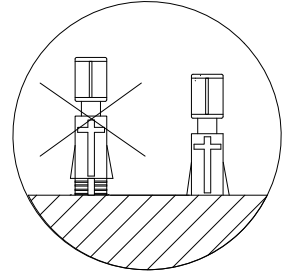
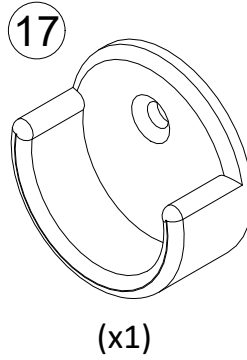
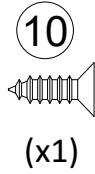
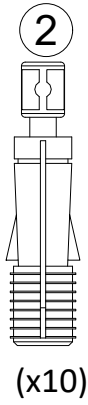
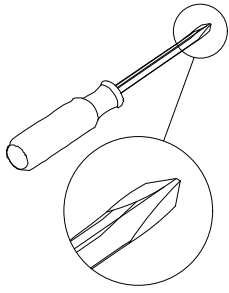

STEP 3

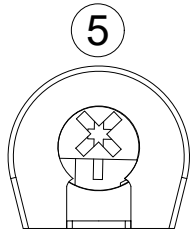
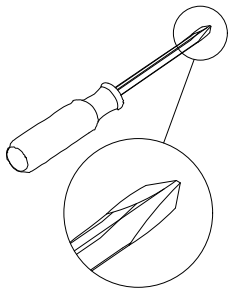

(x4)

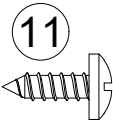

(x3)

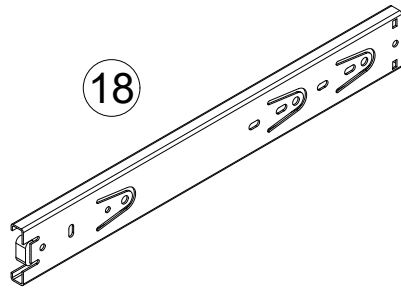

(x1)

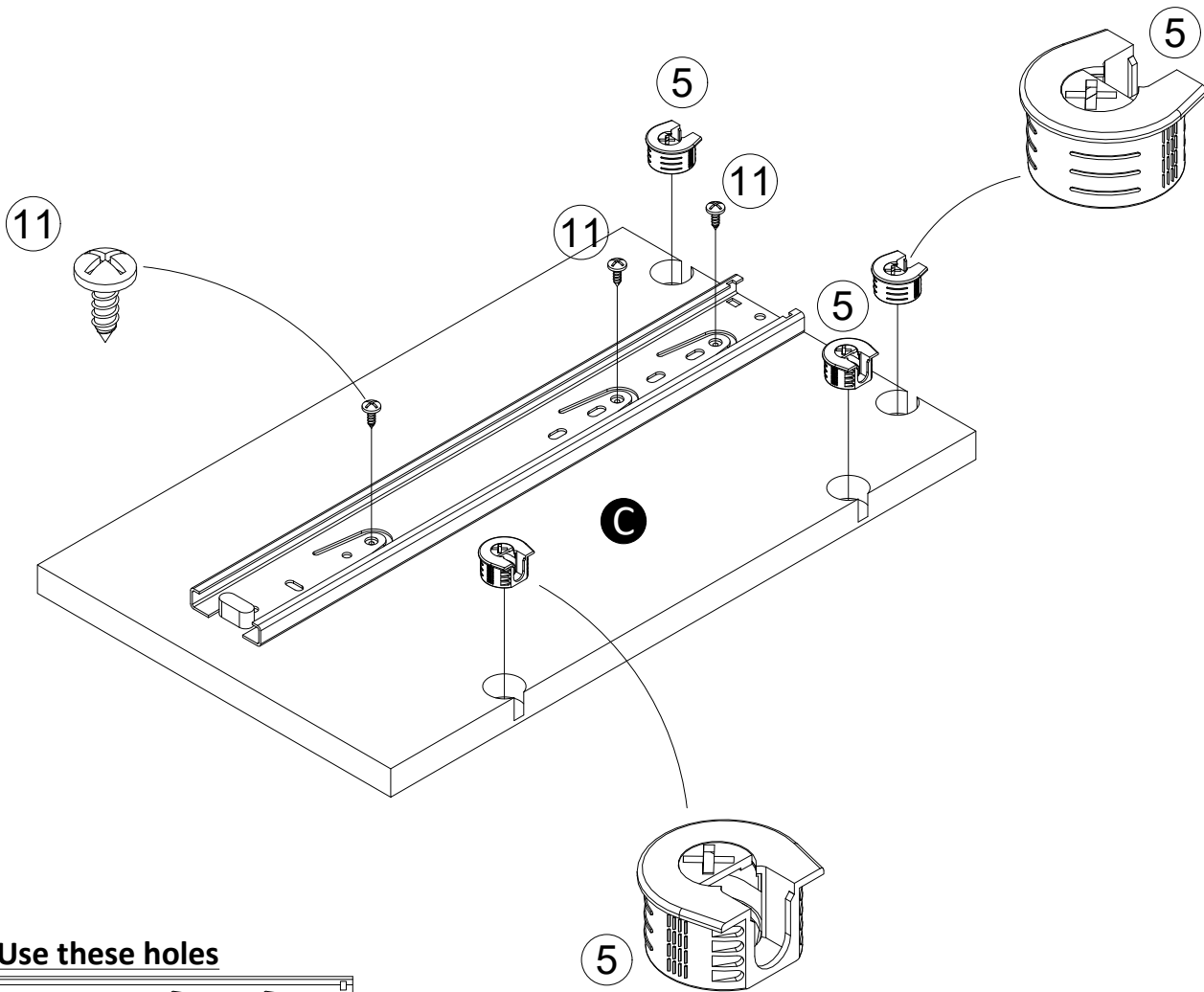

Use these holes



STEP 4

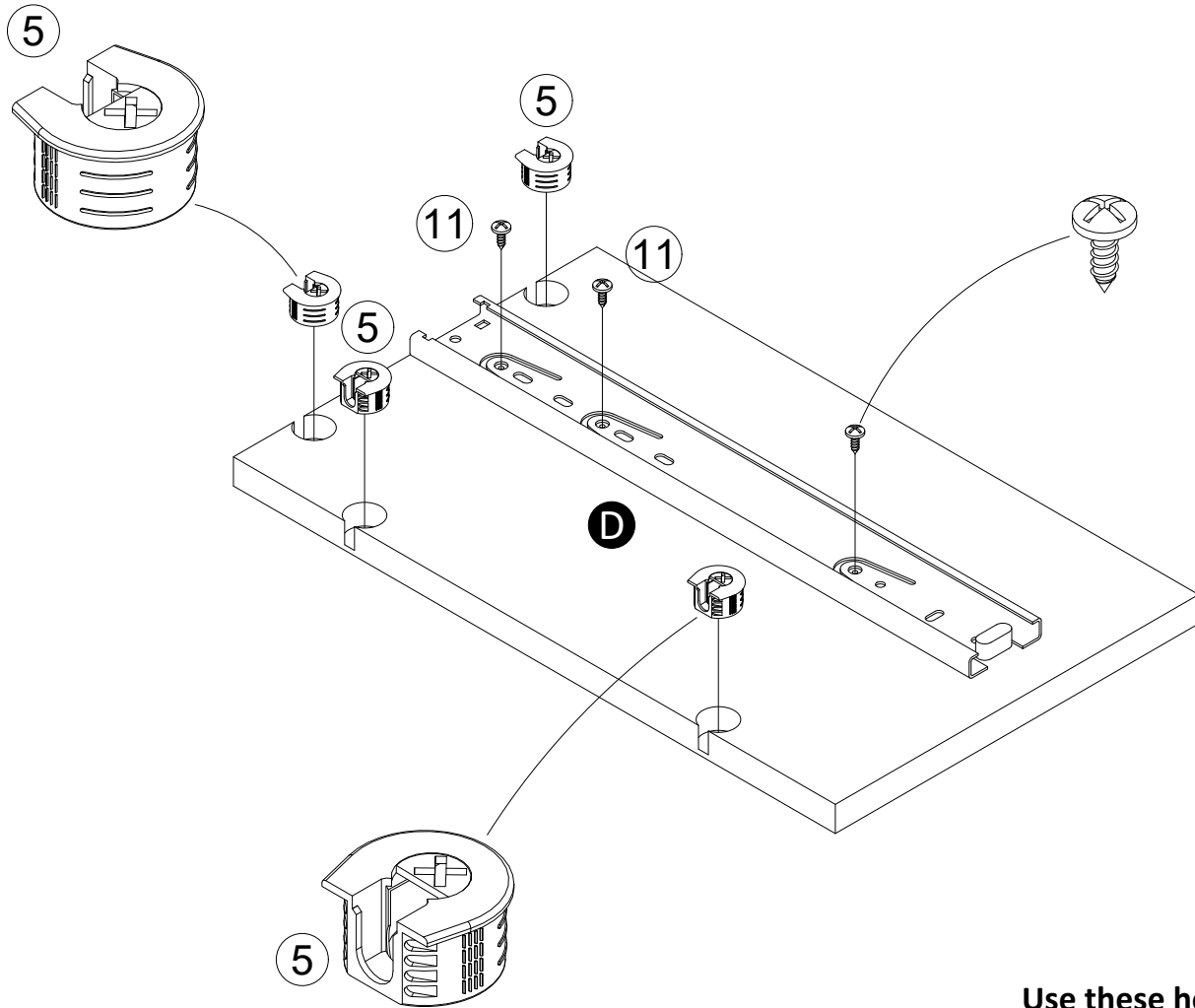
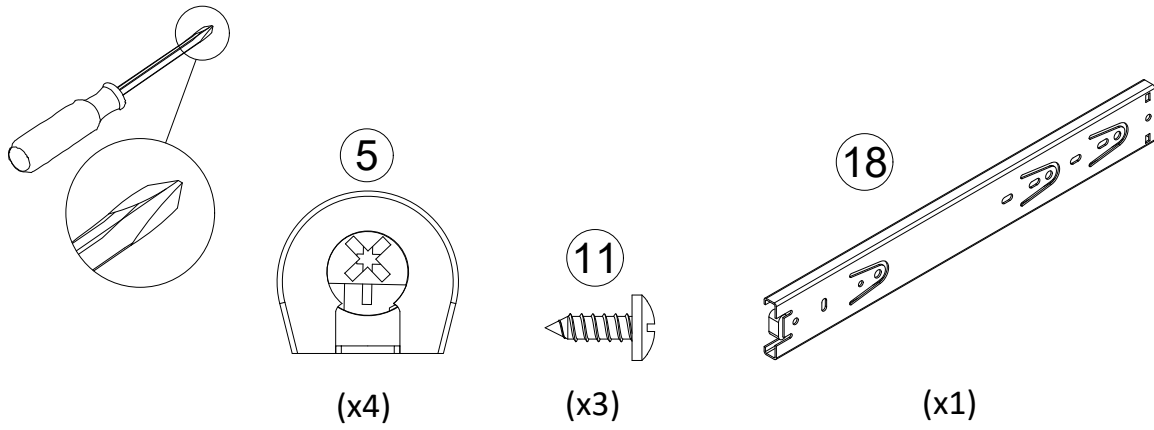

Use these holes

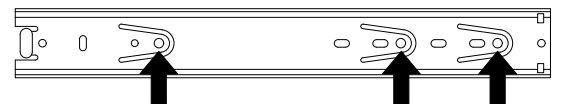

STEP 5

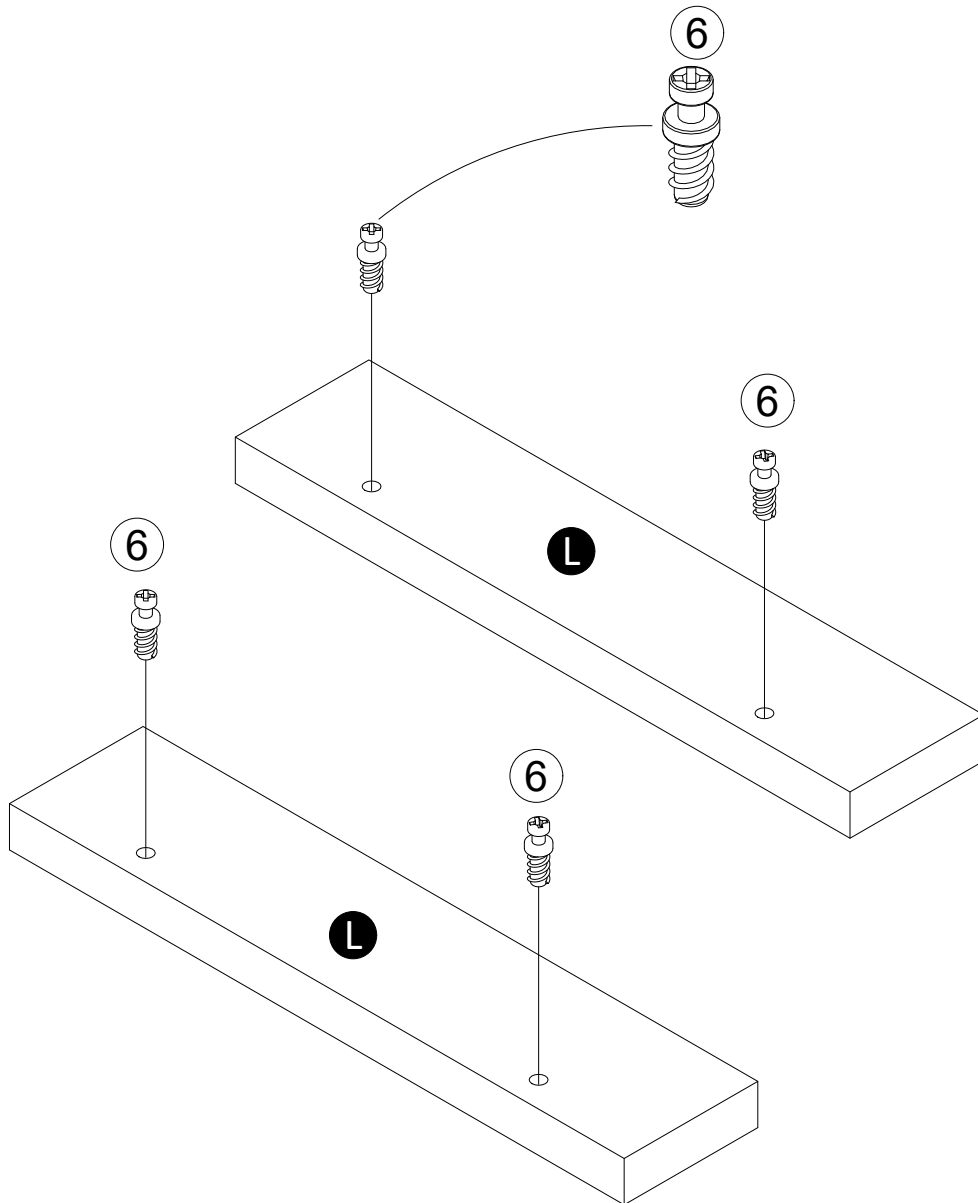
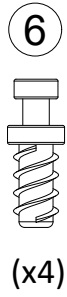
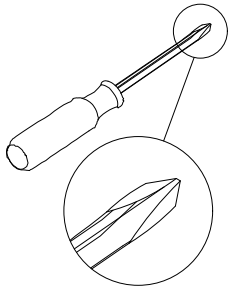

STEP 6

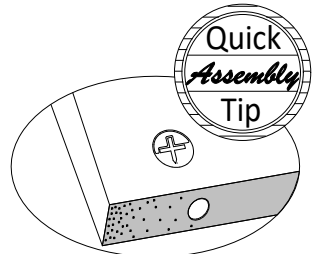
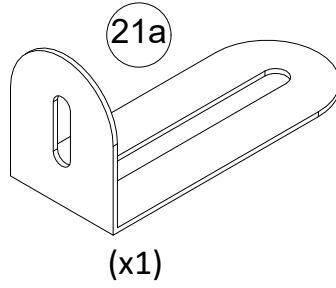
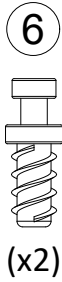
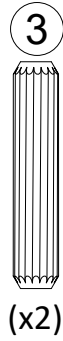
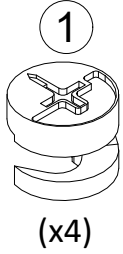
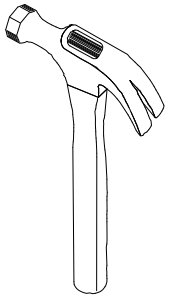
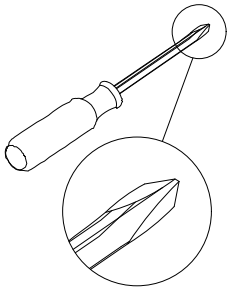

Proper orientation of CAM LOCK

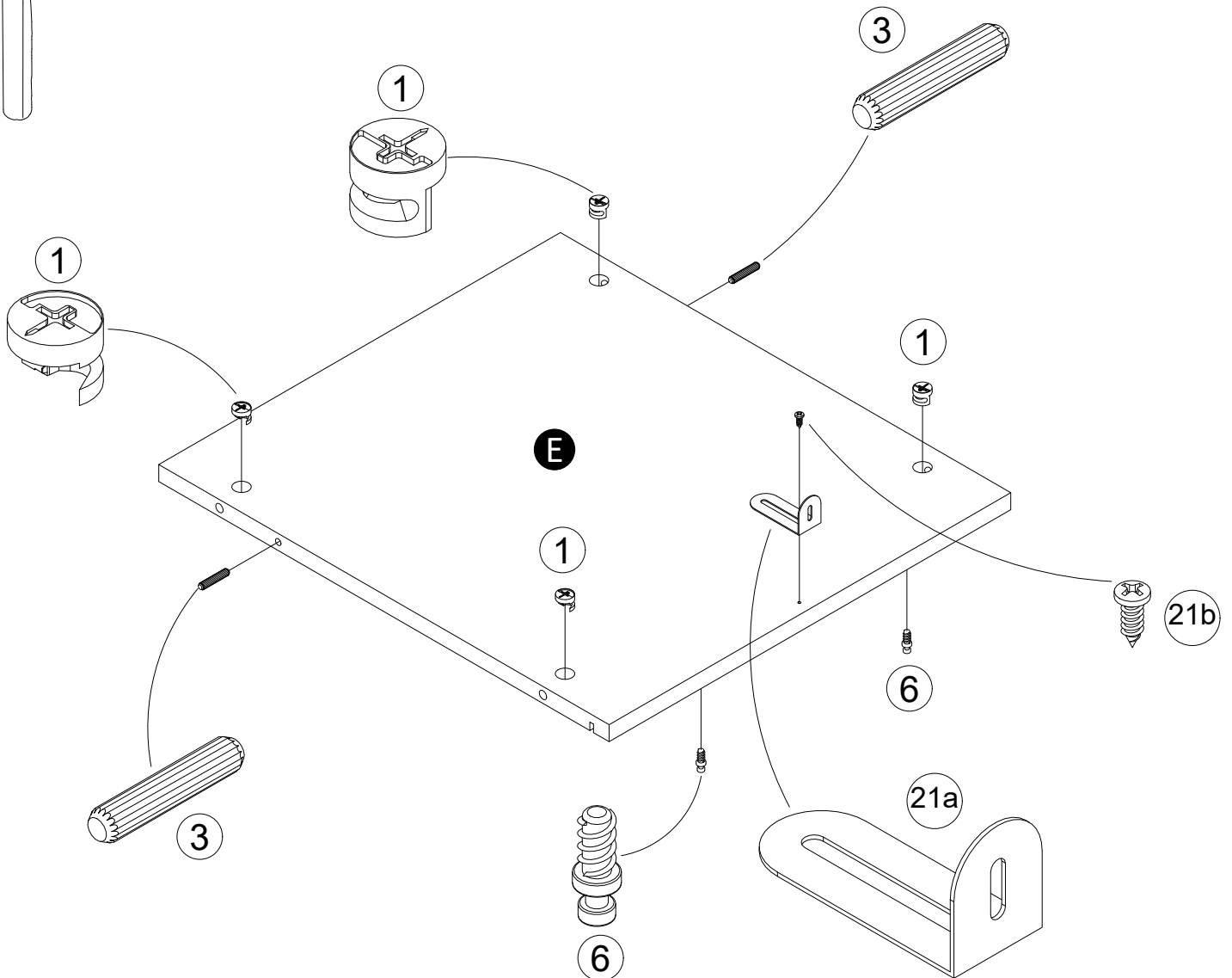

STEP 7

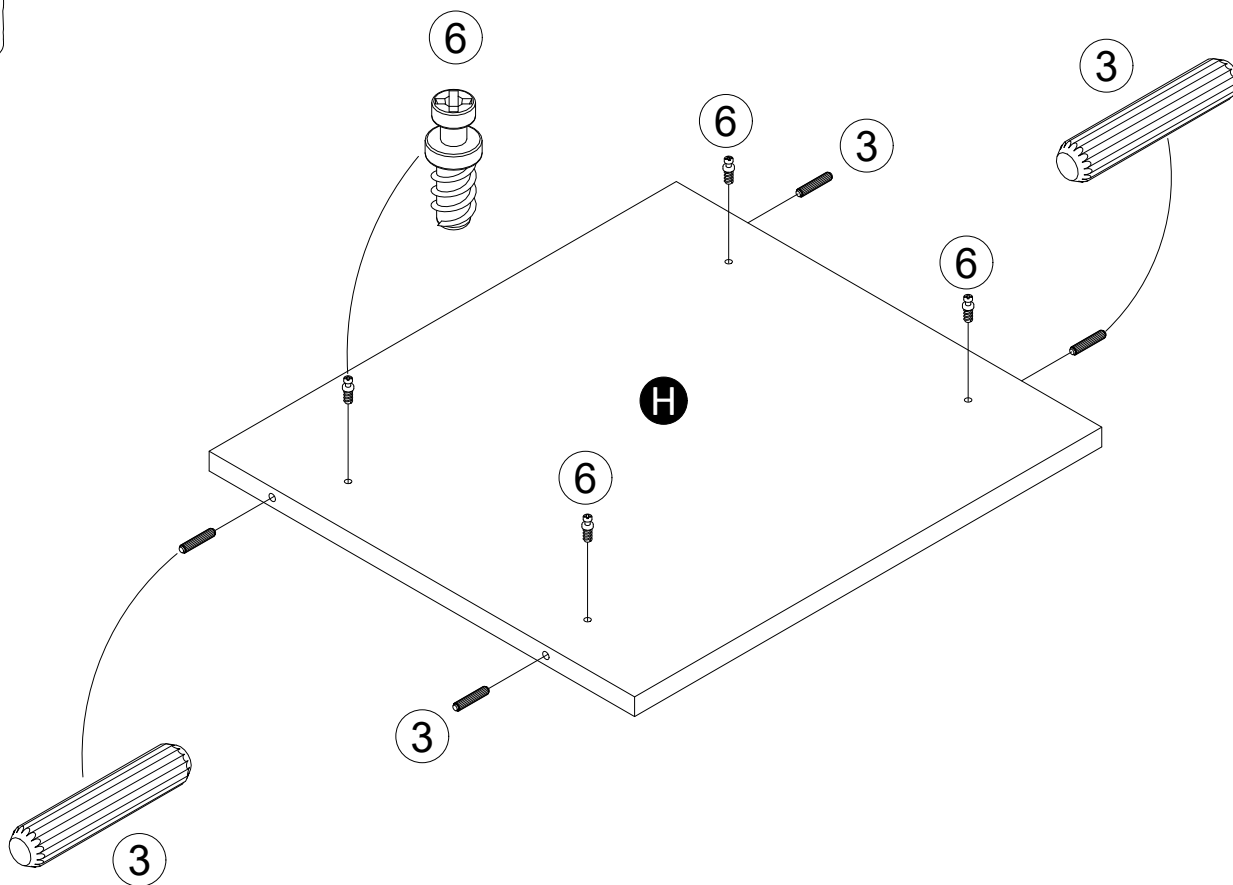
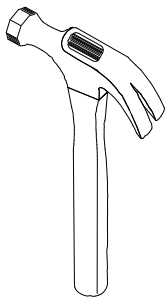
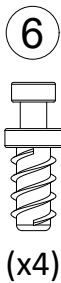
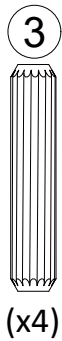
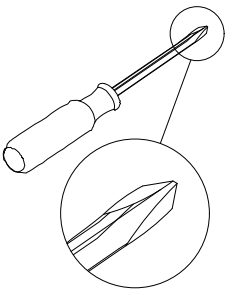

STEP 8

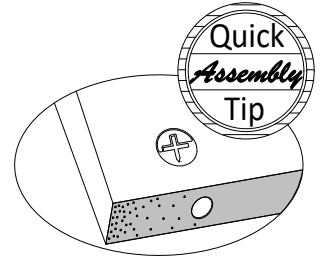
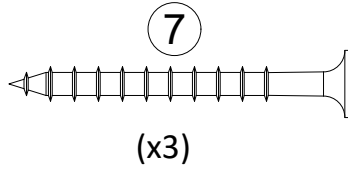
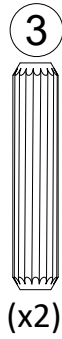
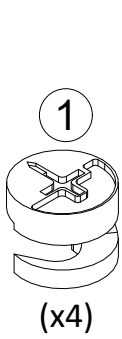
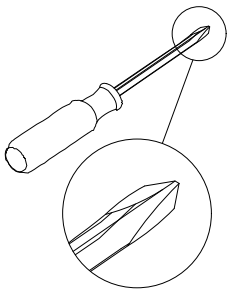

Proper orientation of CAM LOCK

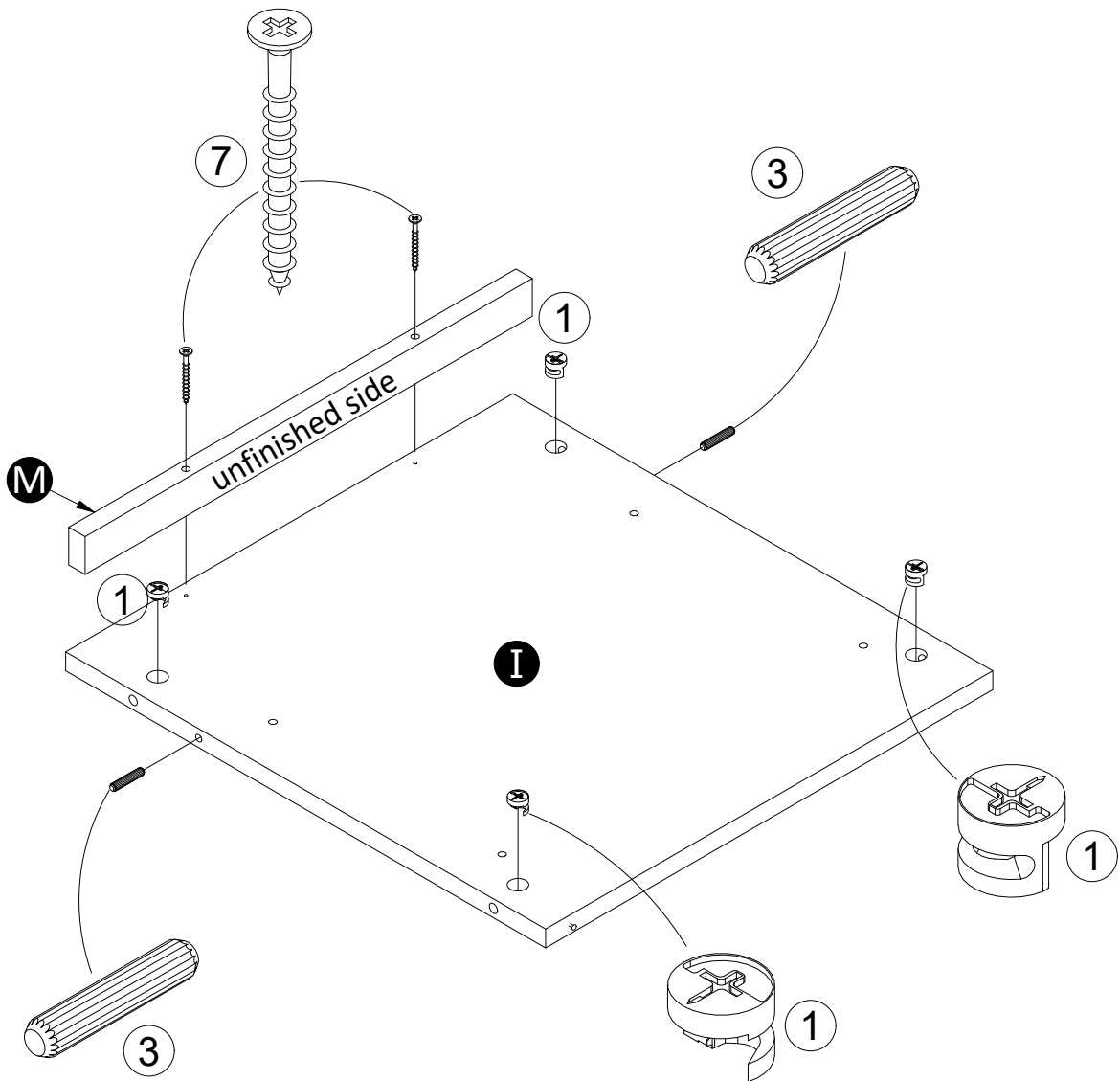
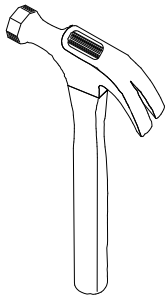

STEP 9

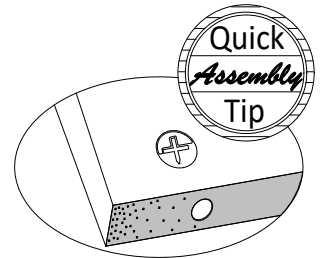
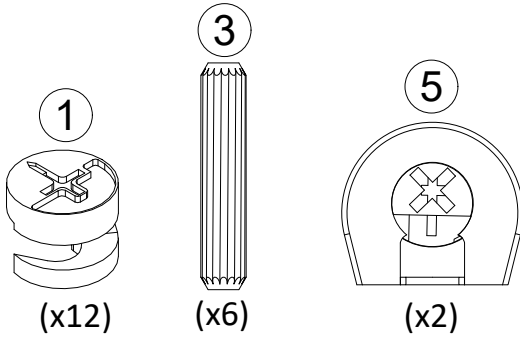
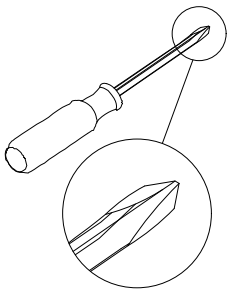

Proper orientation of CAM LOCK

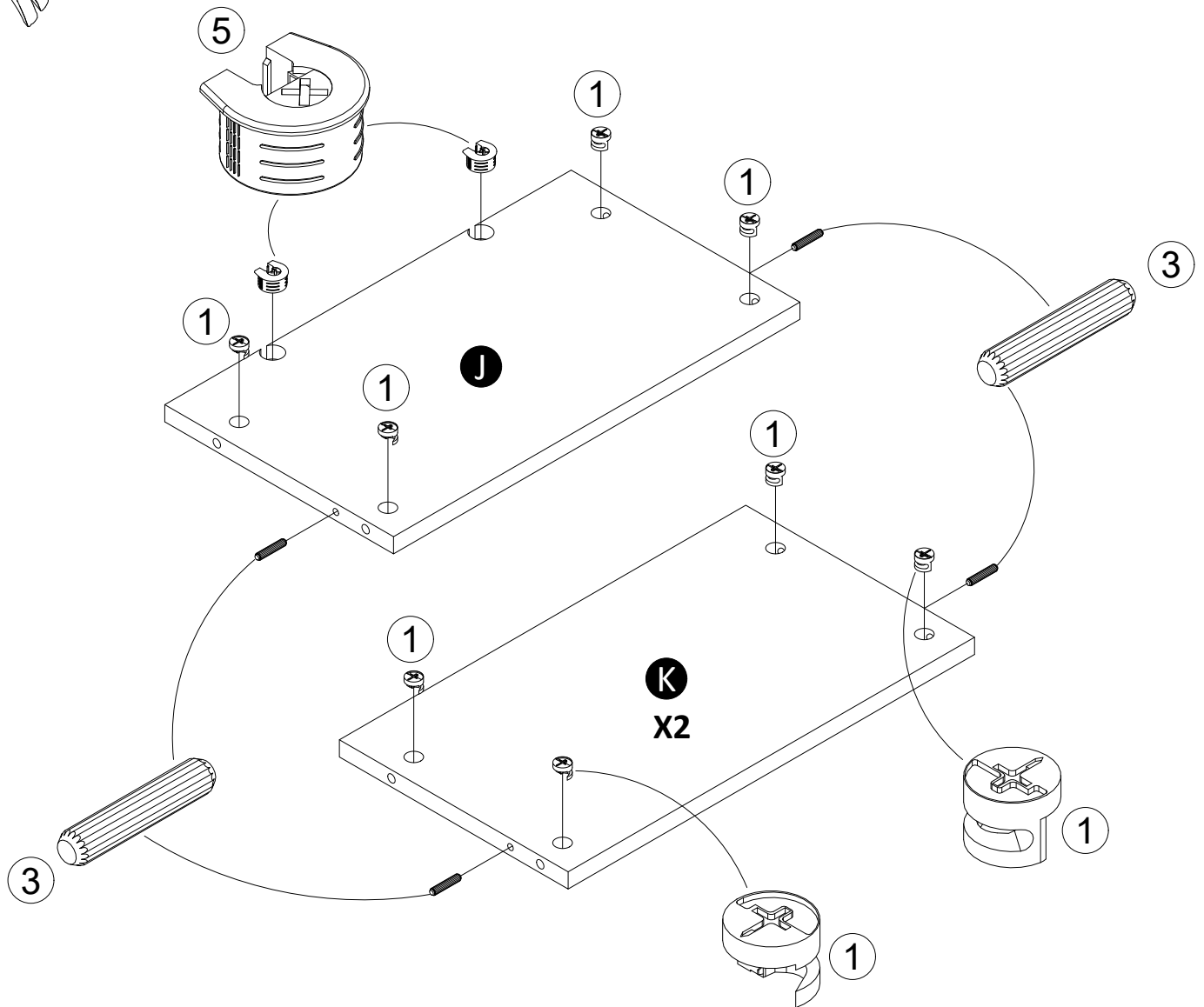
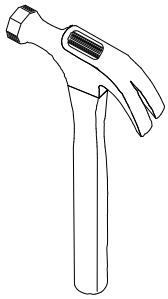

STEP 10

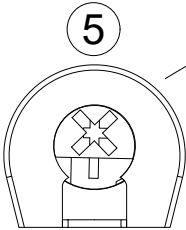
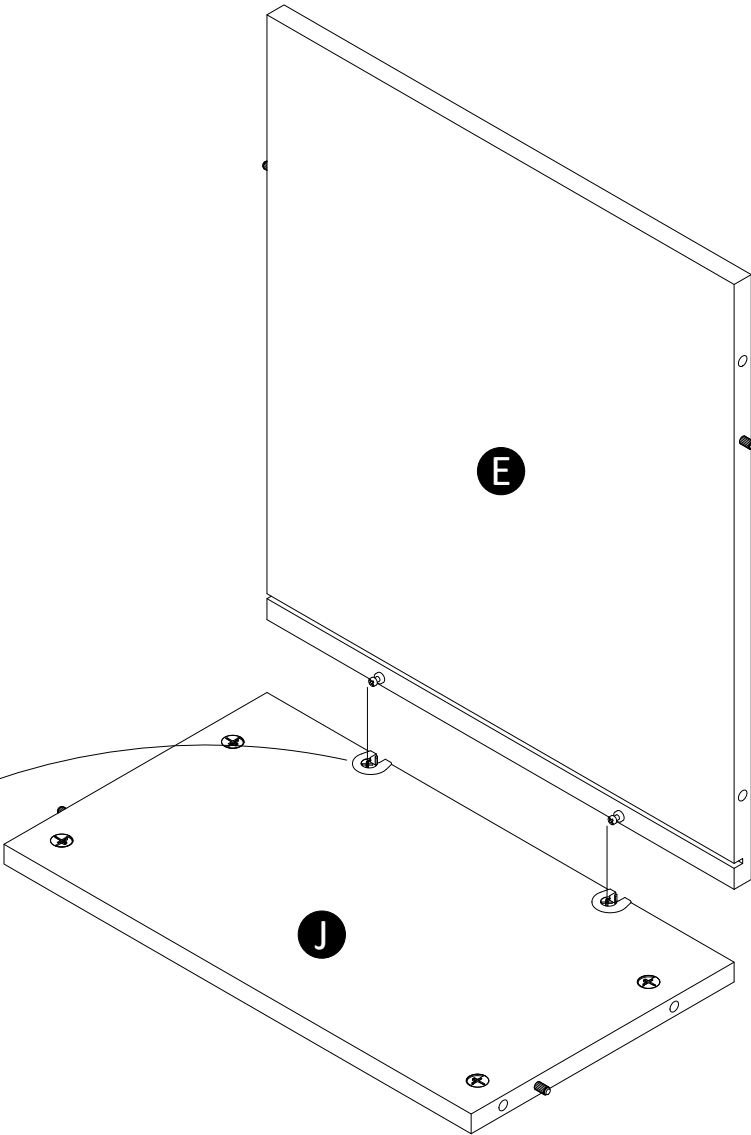
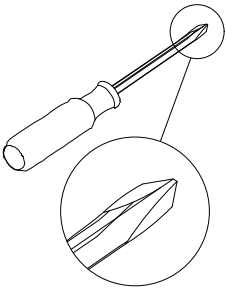

Turn clockwise
to lock in place.

STEP 11

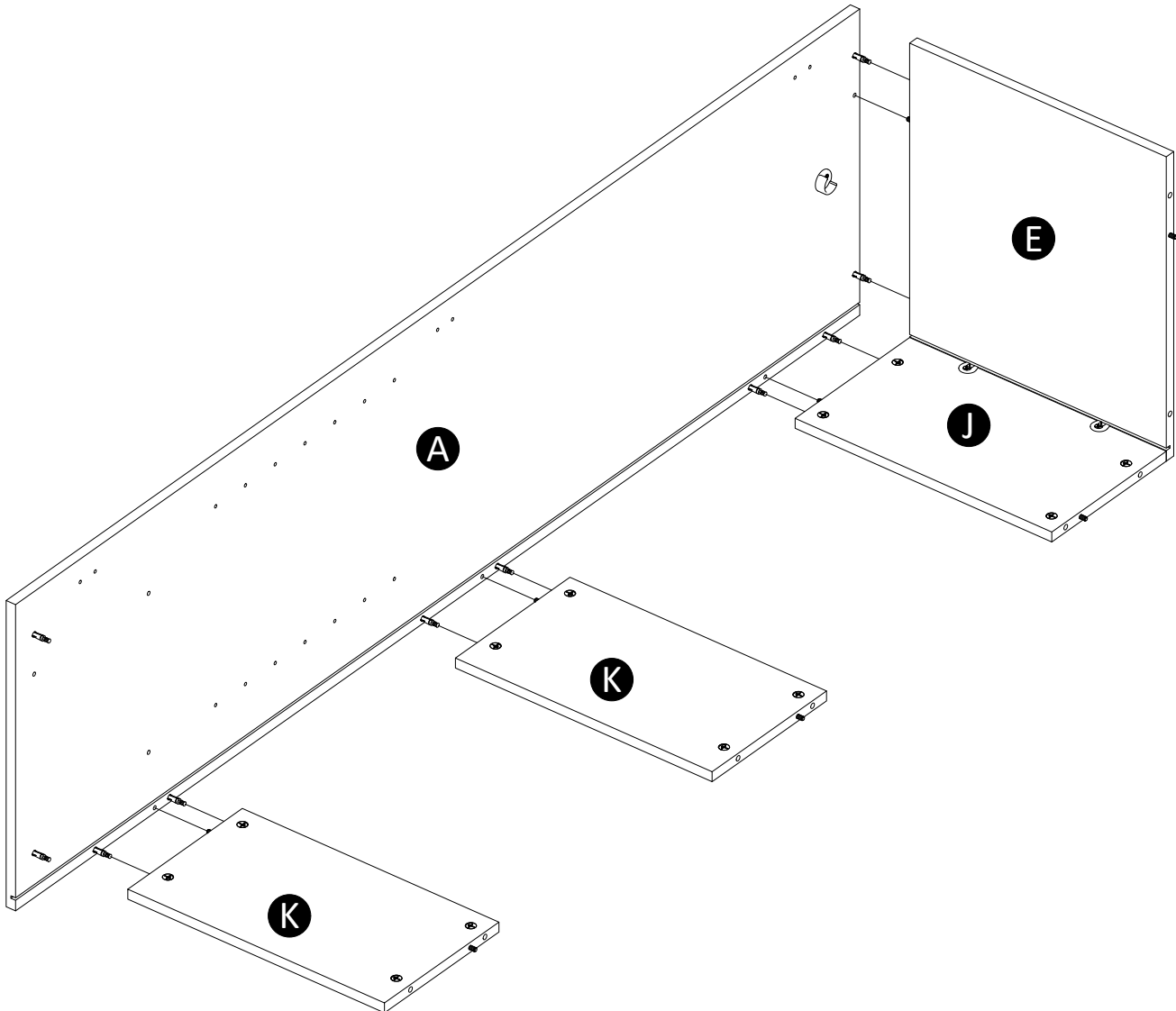
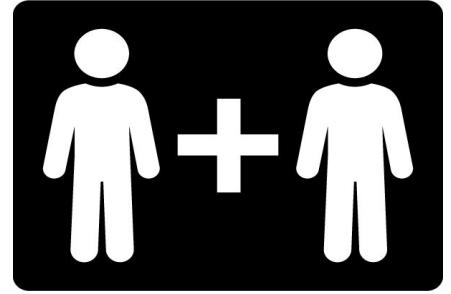
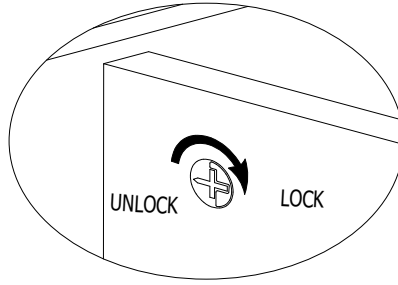
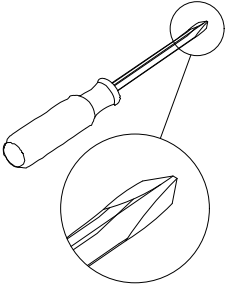

STEP 12

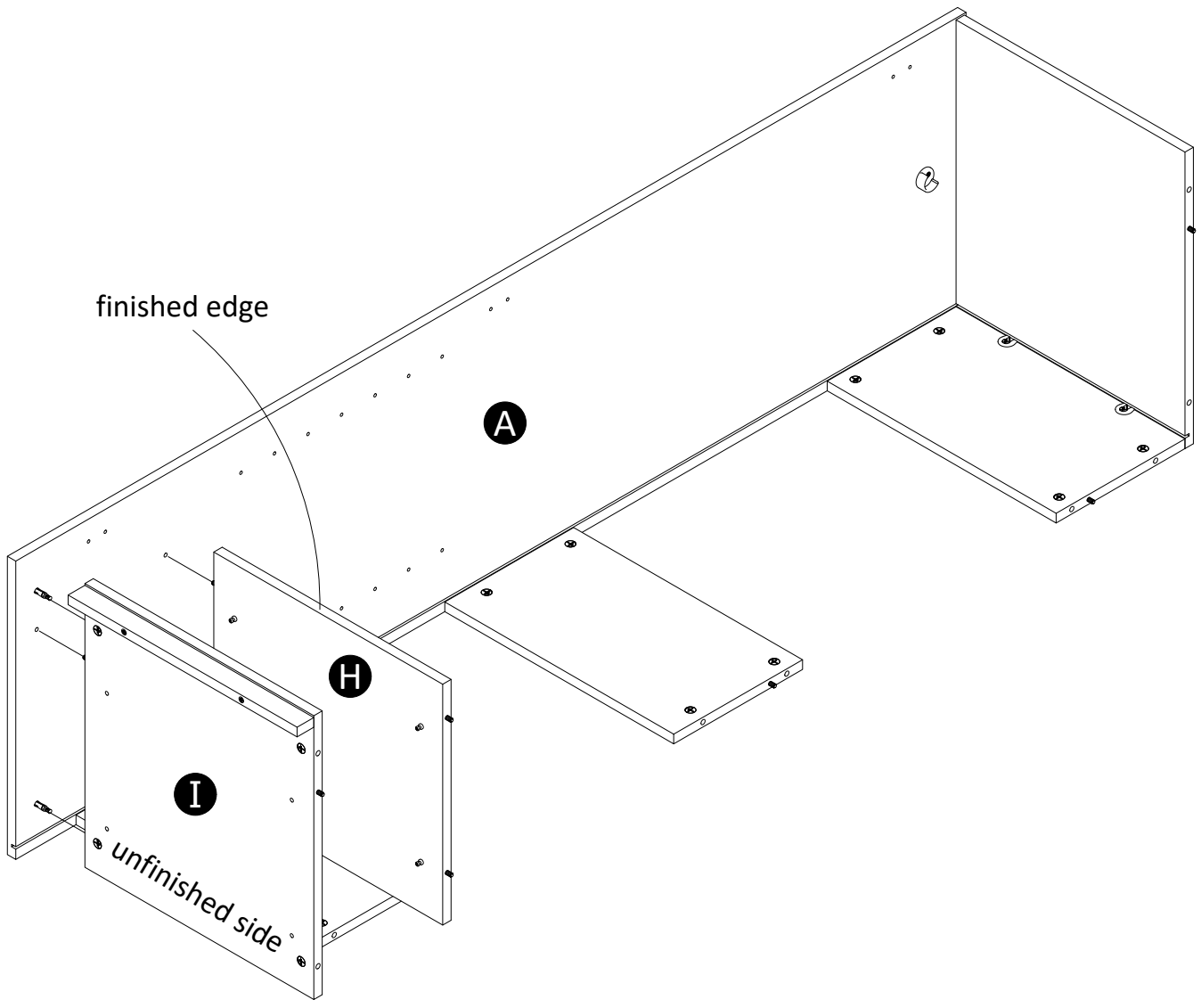
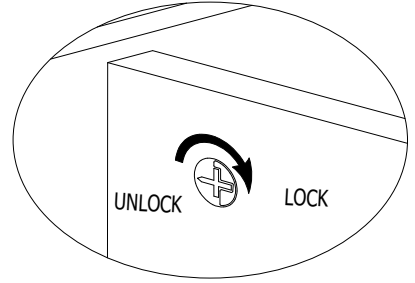
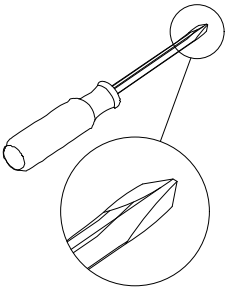

STEP 13

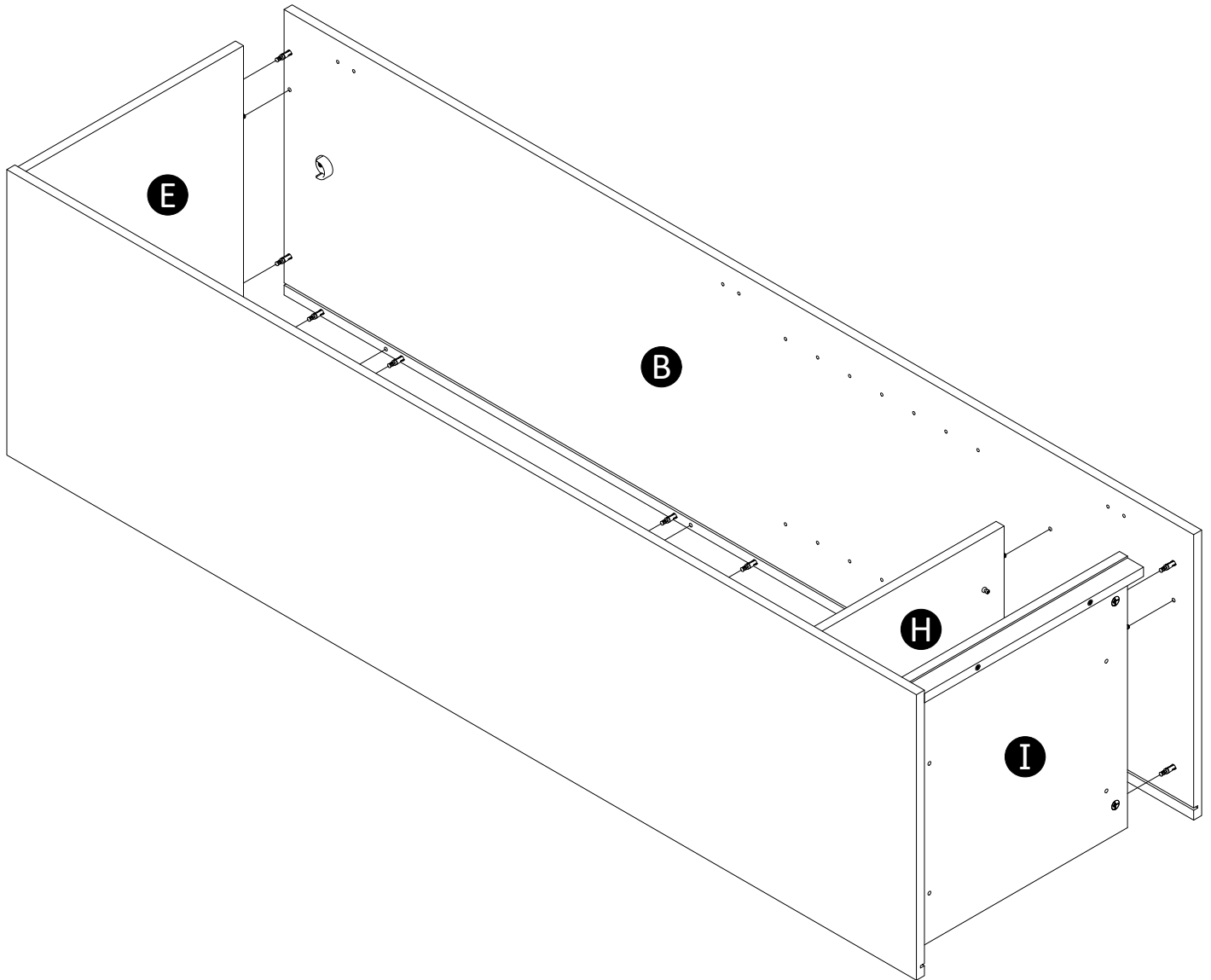
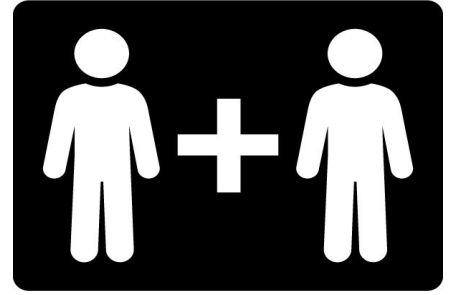
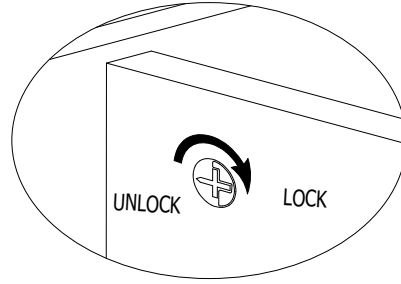
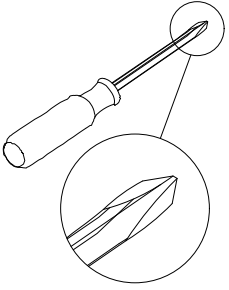

STEP 14

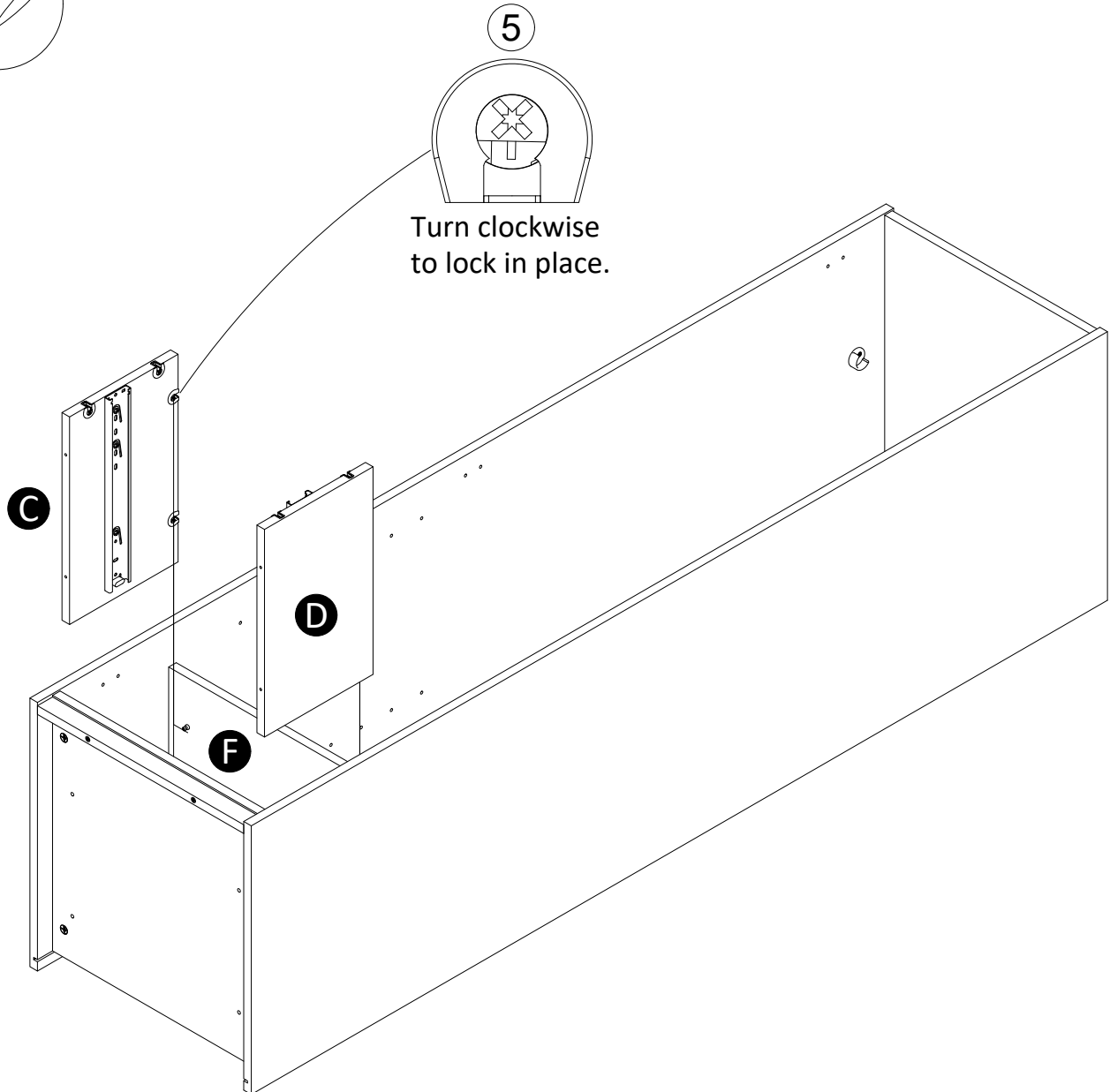
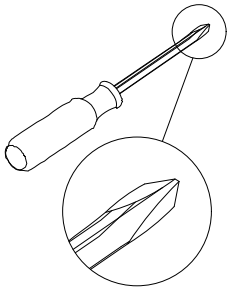

STEP 15

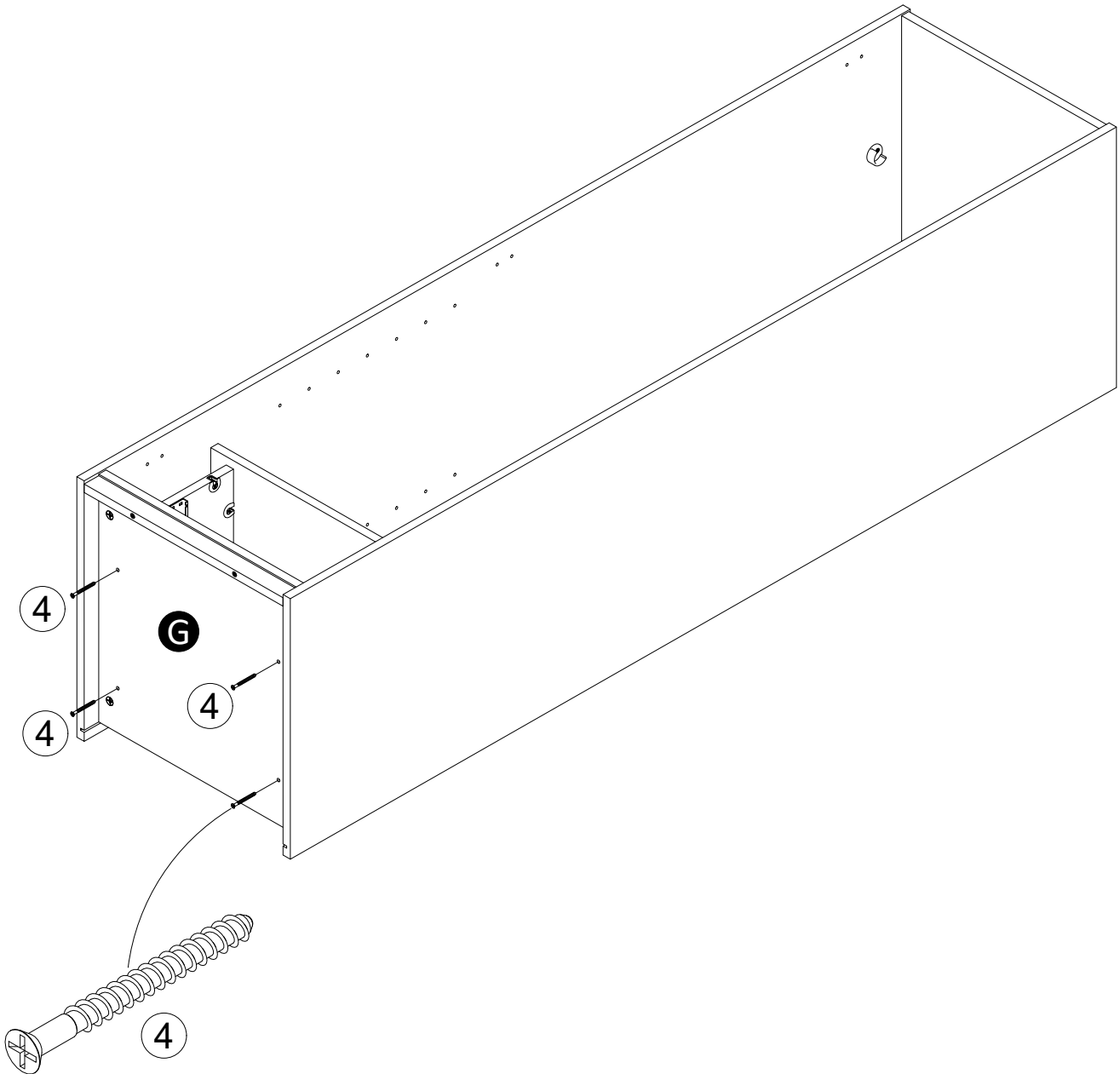
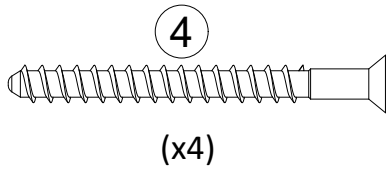
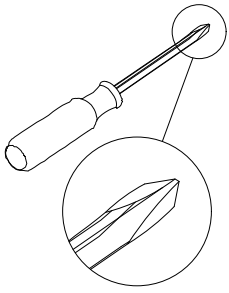

STEP 16

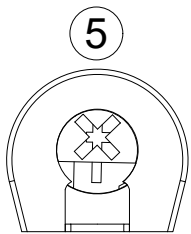
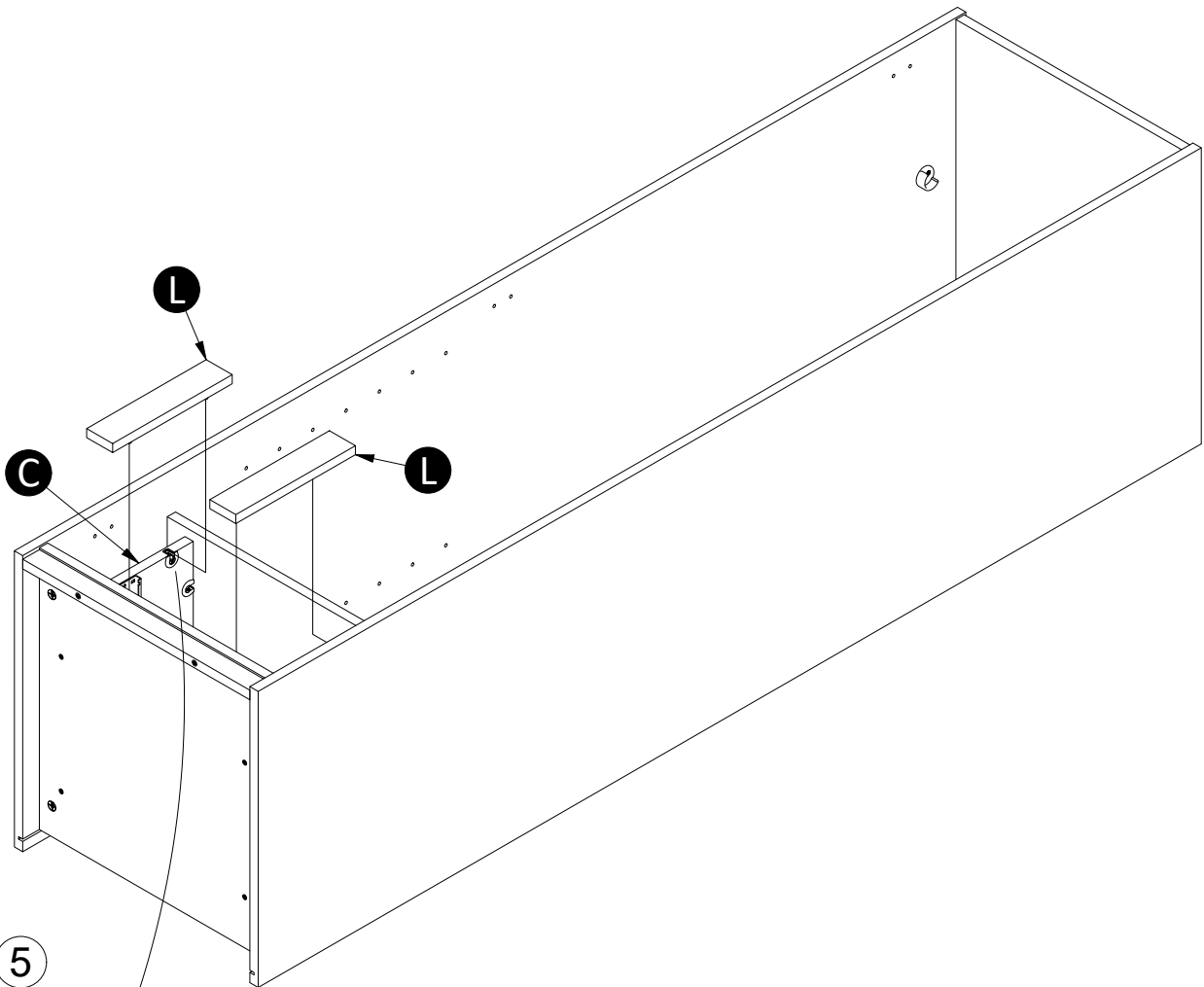
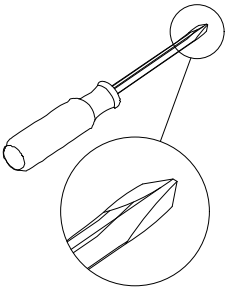

Turn clockwise
to lock in place.

STEP 17

IMPORTANT! THE BACK PANEL IS A STRUCTURAL PART OF THIS UNIT AND MUST BE INSTALLED PROPERLY.

With the help of another person, turn unit on its front side. Unfold the back panel. With uncut side facing down, slide the back panel into the groove in the Left and Right Panels (A&B) seating into the groove in the Top (E). Note, the back panel will be under the supports.

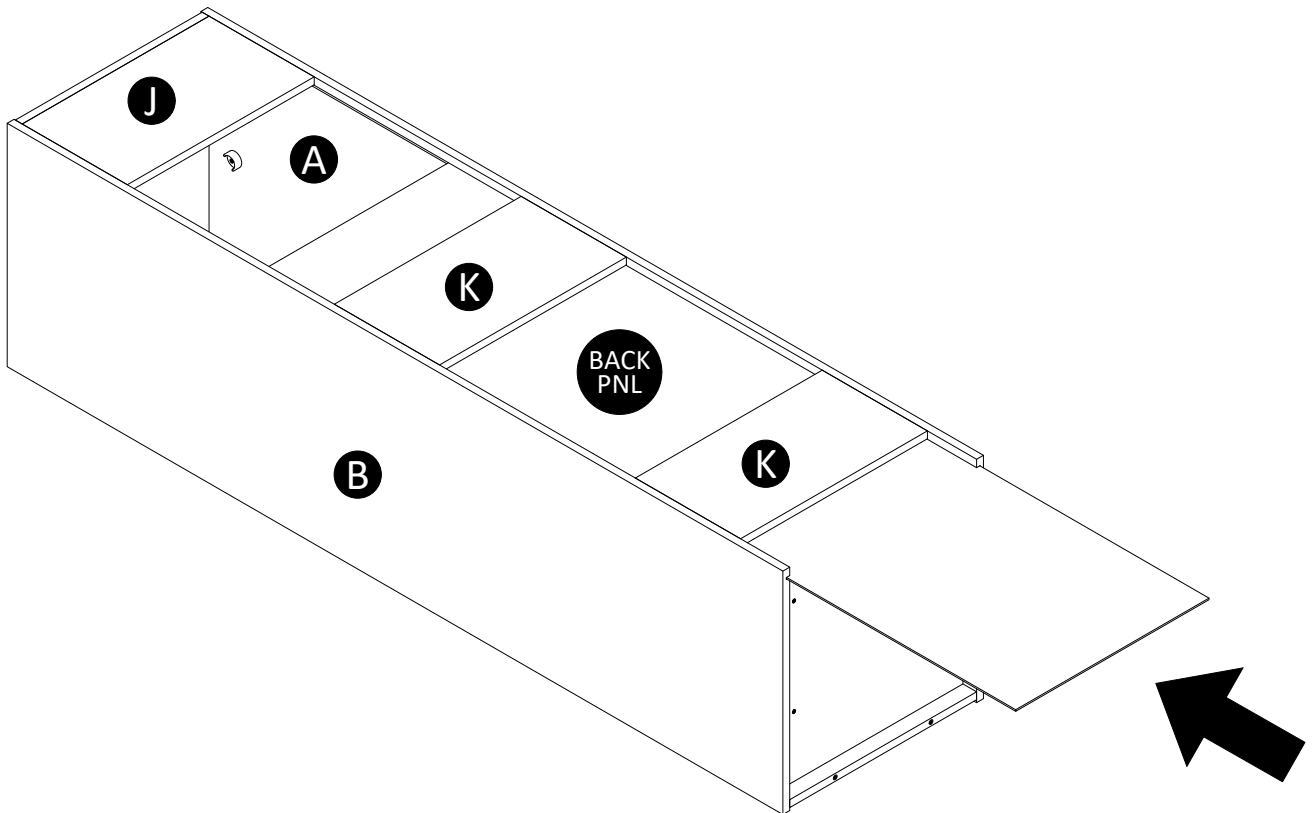
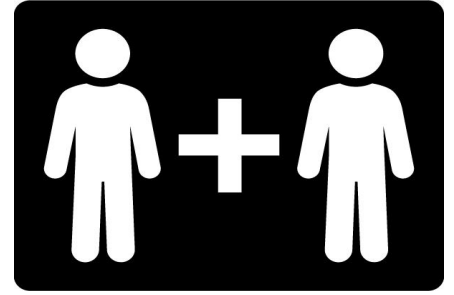

STEP 18

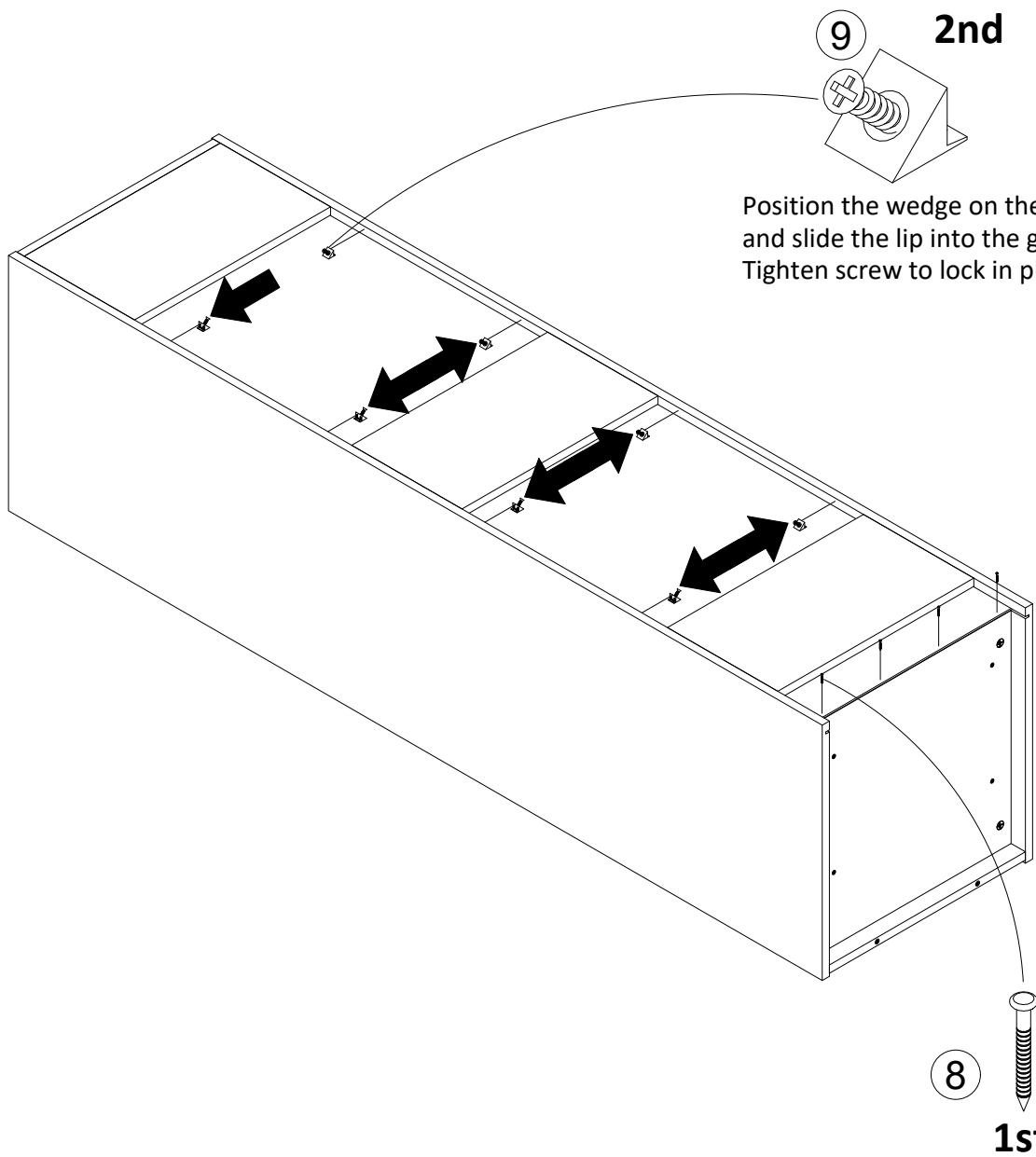
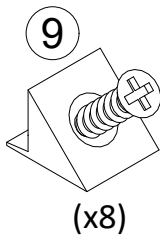
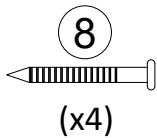
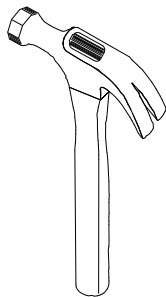
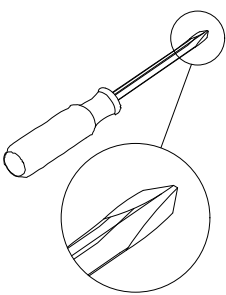

STEP 19

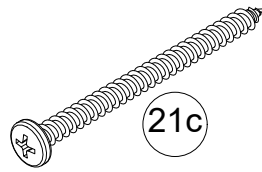
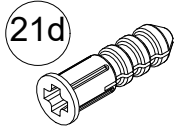

For Masonry, Concrete, or other wall materials:

Consult your local hardware store for appropriate anchors to securely attach the safety bracket.

IMPORTANT: THIS UNIT MUST BE SECURE TO THE WALL TO HELP PREVENT TIPOVER. FOLLOW THESE INSTRUCTIONS TO INSTALL THE ANTI-TIPPING SAFETY BRACKET PROVIDED WITH THIS PRODUCT.

WARNING

Serious or fatal crushing injuries can occur from furniture tipover.

To prevent tipover:

- * Install tipover restraint provided
- * place heaviest items in the lowest drawers
- * Unless specifically designed to accommodate, do not set TVs or other heavy objects on the top of this product
- * Never allow children to climb or hang on drawers, door, or shelves
- * Never open more than one drawer at a time

Use of tipover restraints may only reduce, but not eliminate the risk of tipover

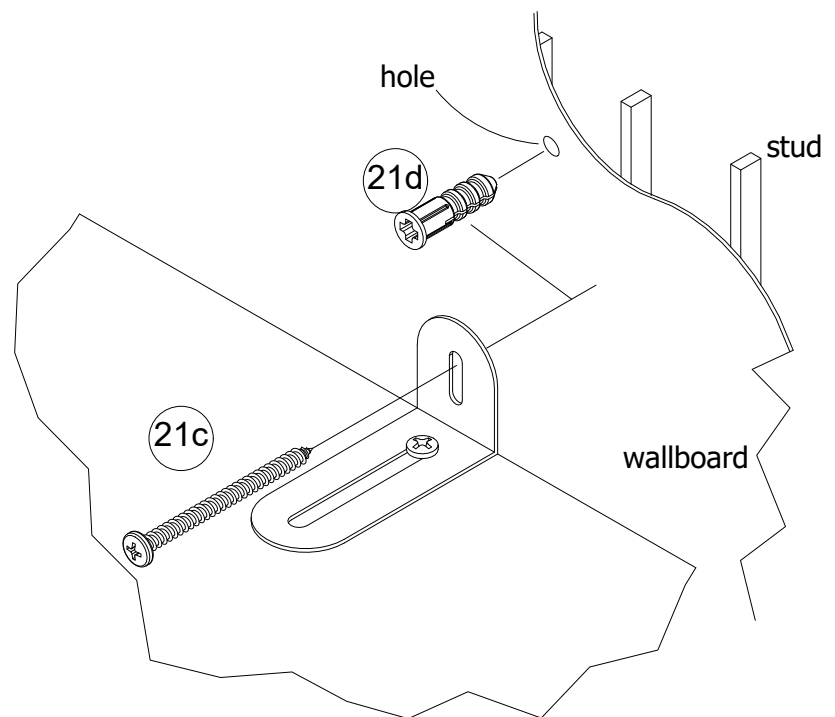

OPTION 1: Attachment into a wall stud (preferred method)

Using a stud finder, locate a stud in the wall. Place your unit against the wall, with the safety bracket aligned in this location. To make driving the screw easier, you can drill a 1/8" diameter pilot hole (3mm) through the safety bracket into the stud. Drive the screw through the safety bracket into the wall stud. Tighten the screw that was not fully tightened in step 1.

OPTION 2: Attachment into drywall

Locate your unit where desired against a wall and mark the wall through the safety bracket, then move your unit aside. Drill a 3/16" diameter hole (5mm) into the wallboard. Tap the wall anchor into the hole until it is flush. Move your unit into location and fasten the wall bracket to the wall anchor with the screw. Tighten the screw that was not fully tightened in step 1.

STEP 20

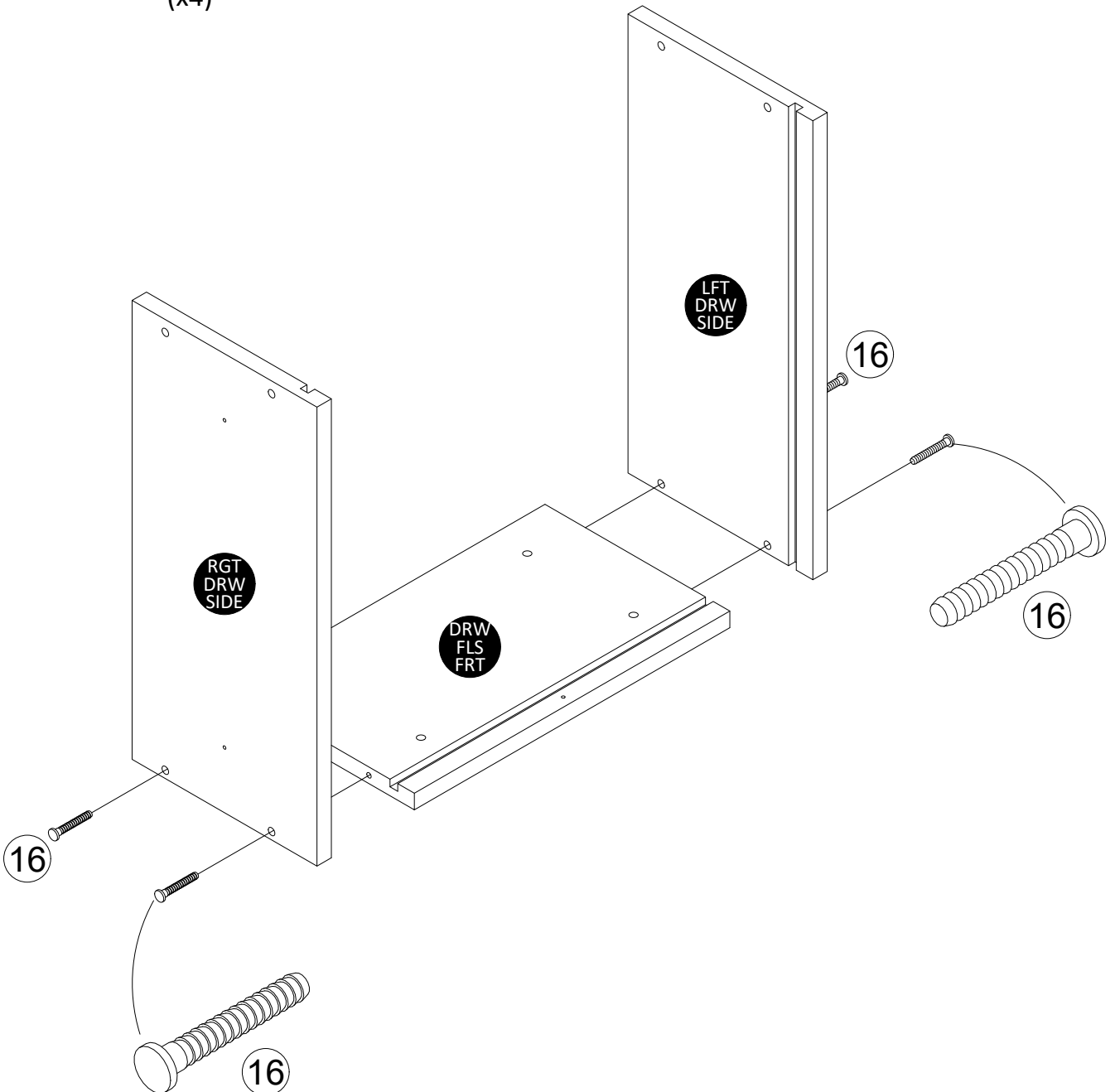
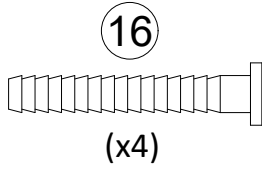
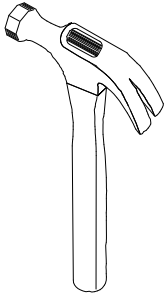

STEP 21

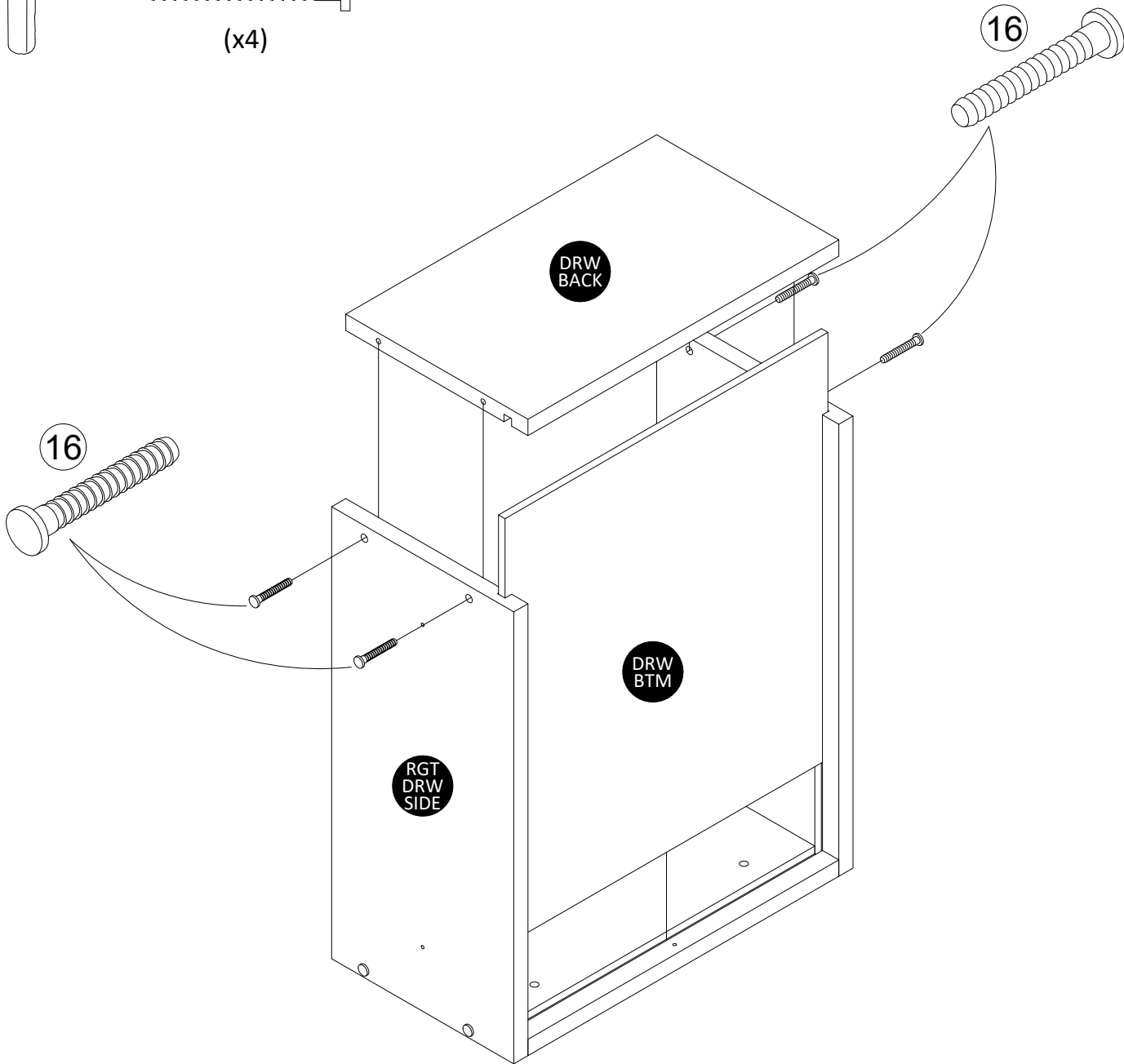
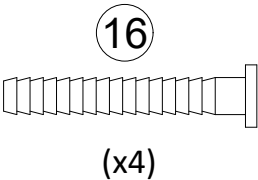
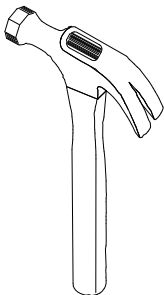

STEP 22

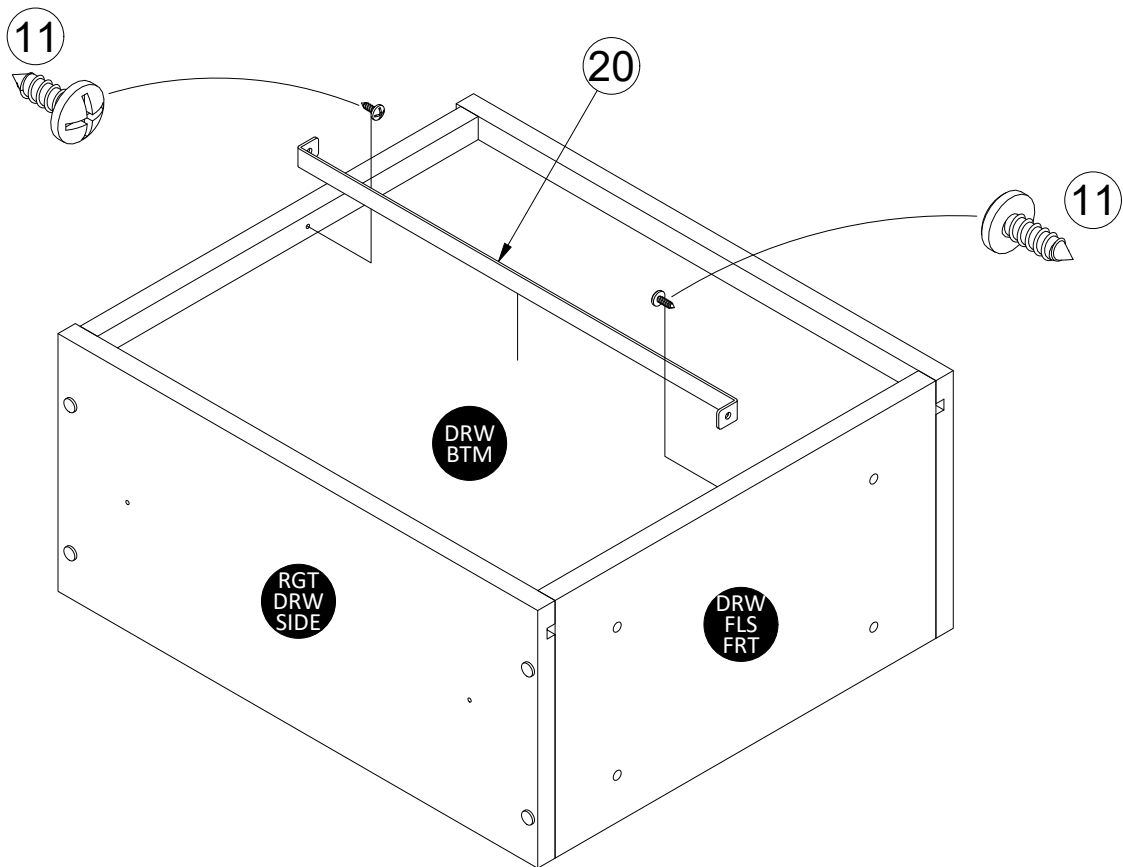
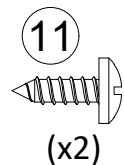
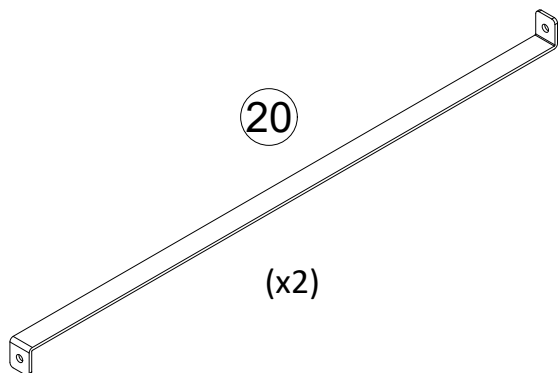
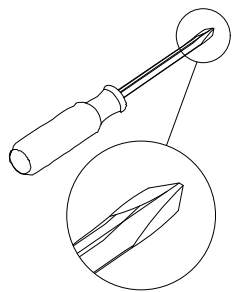

STEP 23

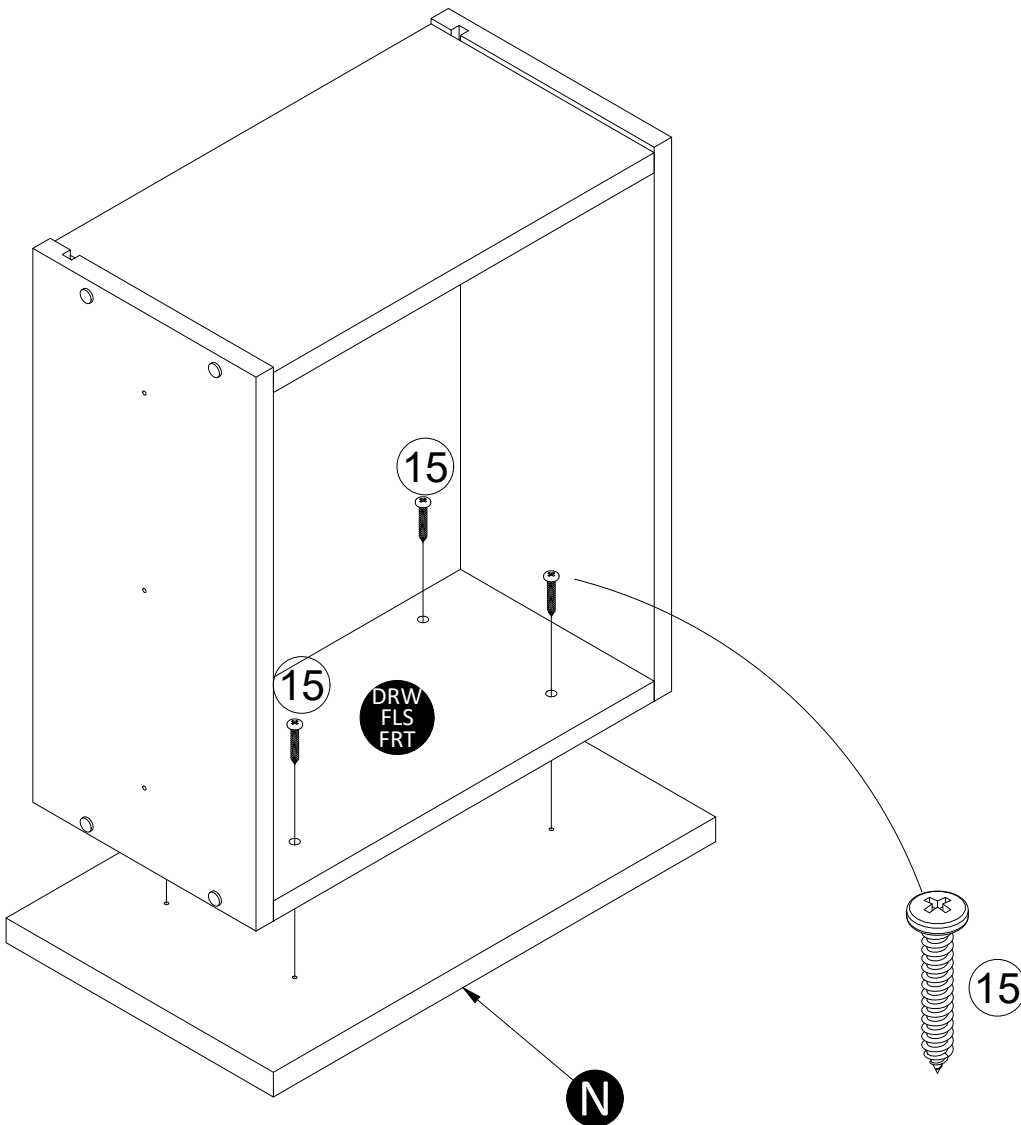
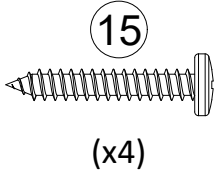
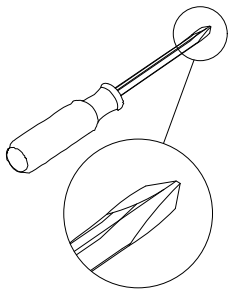

STEP 24

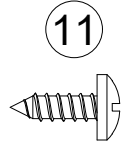
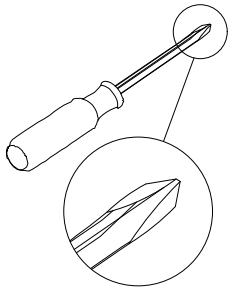

(x6)

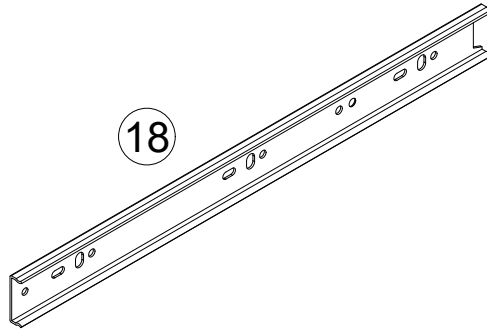

(x2)

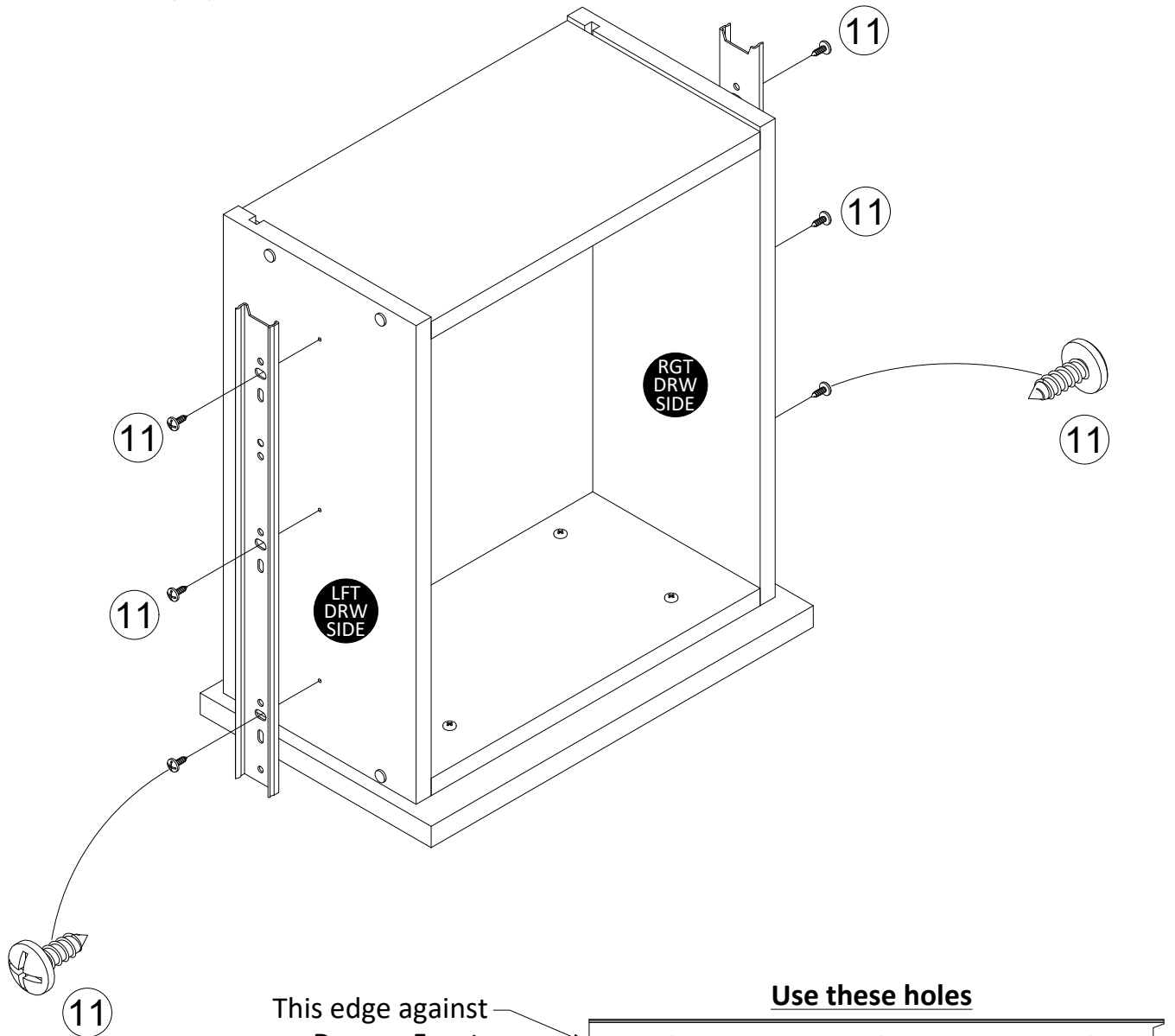

This edge against
Drawer Front.

Use these holes

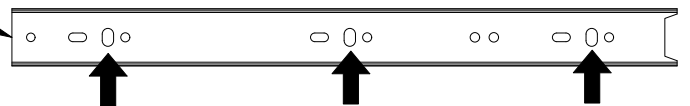

STEP 25

Install drawers by engaging the inner slides (attached to drawer sides) with the out slides attached to the left and right inner uprights. Push in until plastic lever snaps into the outer slide.

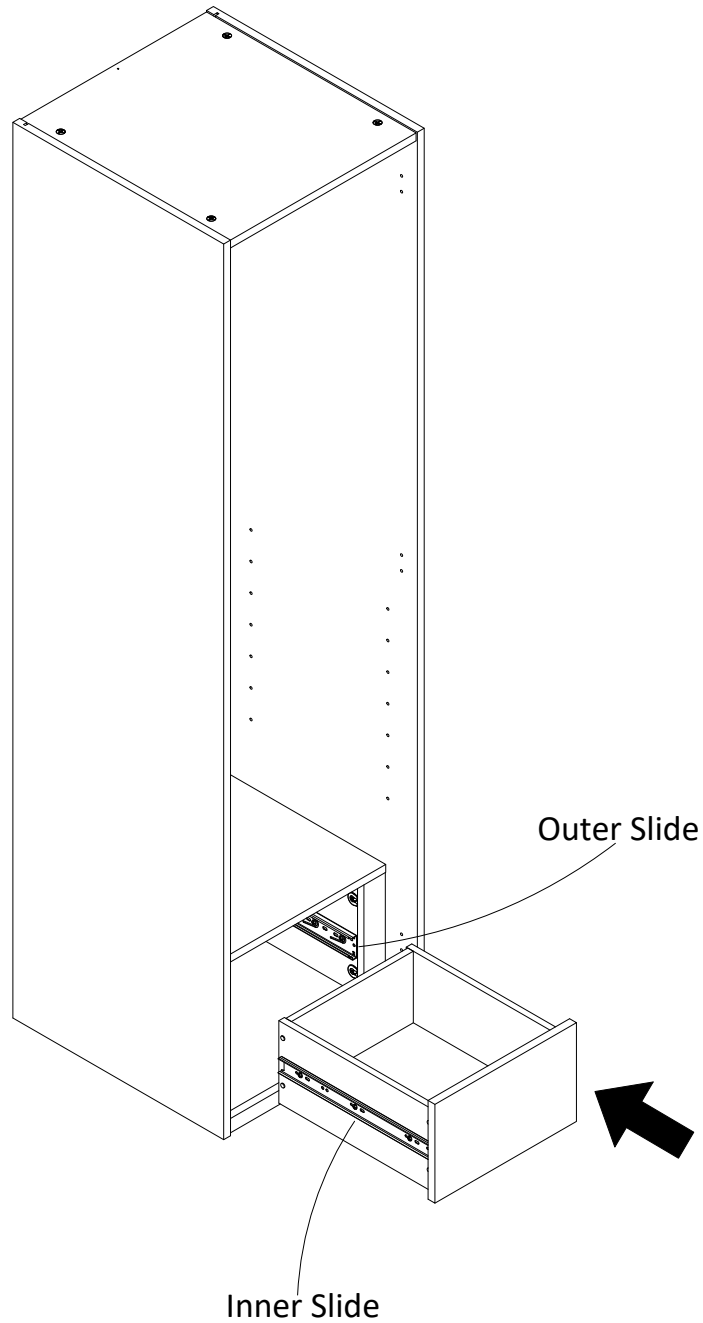

STEP 26

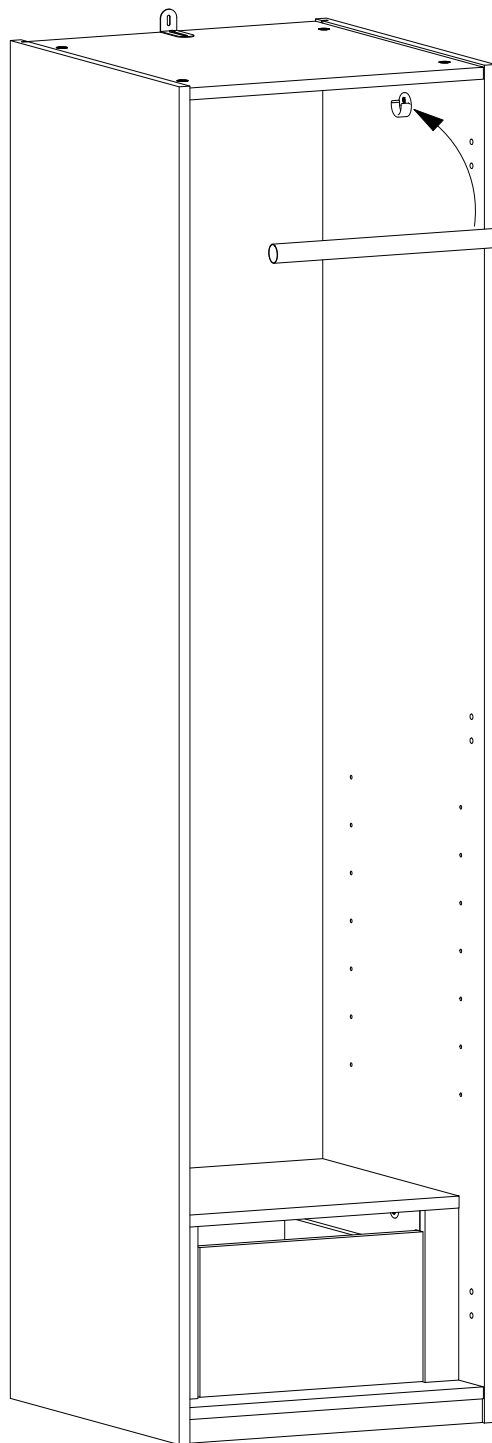

19

Place closet rod onto rod bracket.

STEP 27

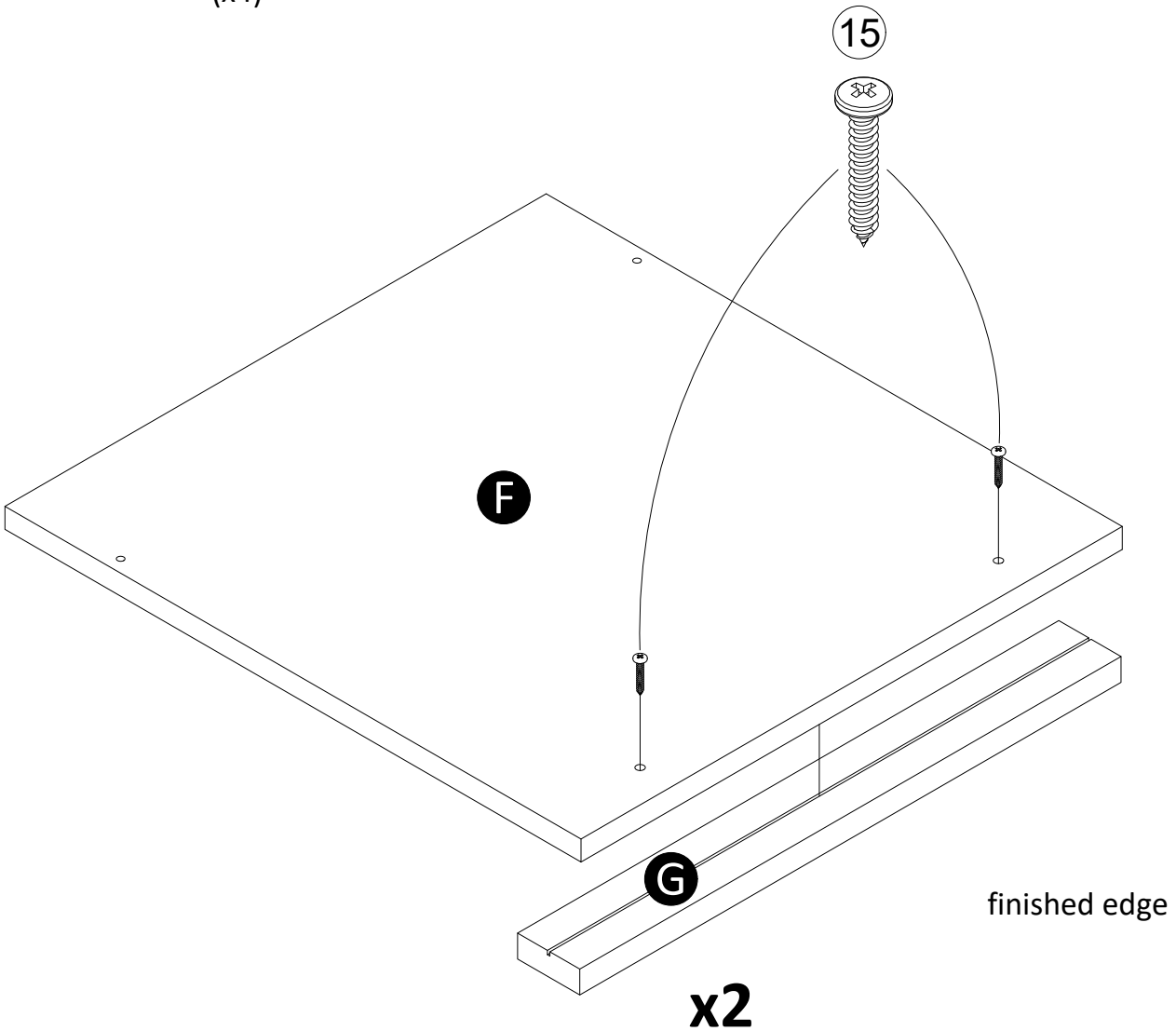
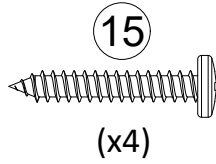
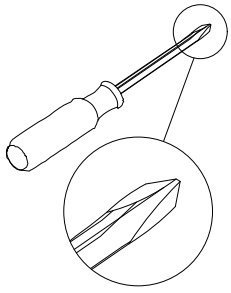

STEP 28

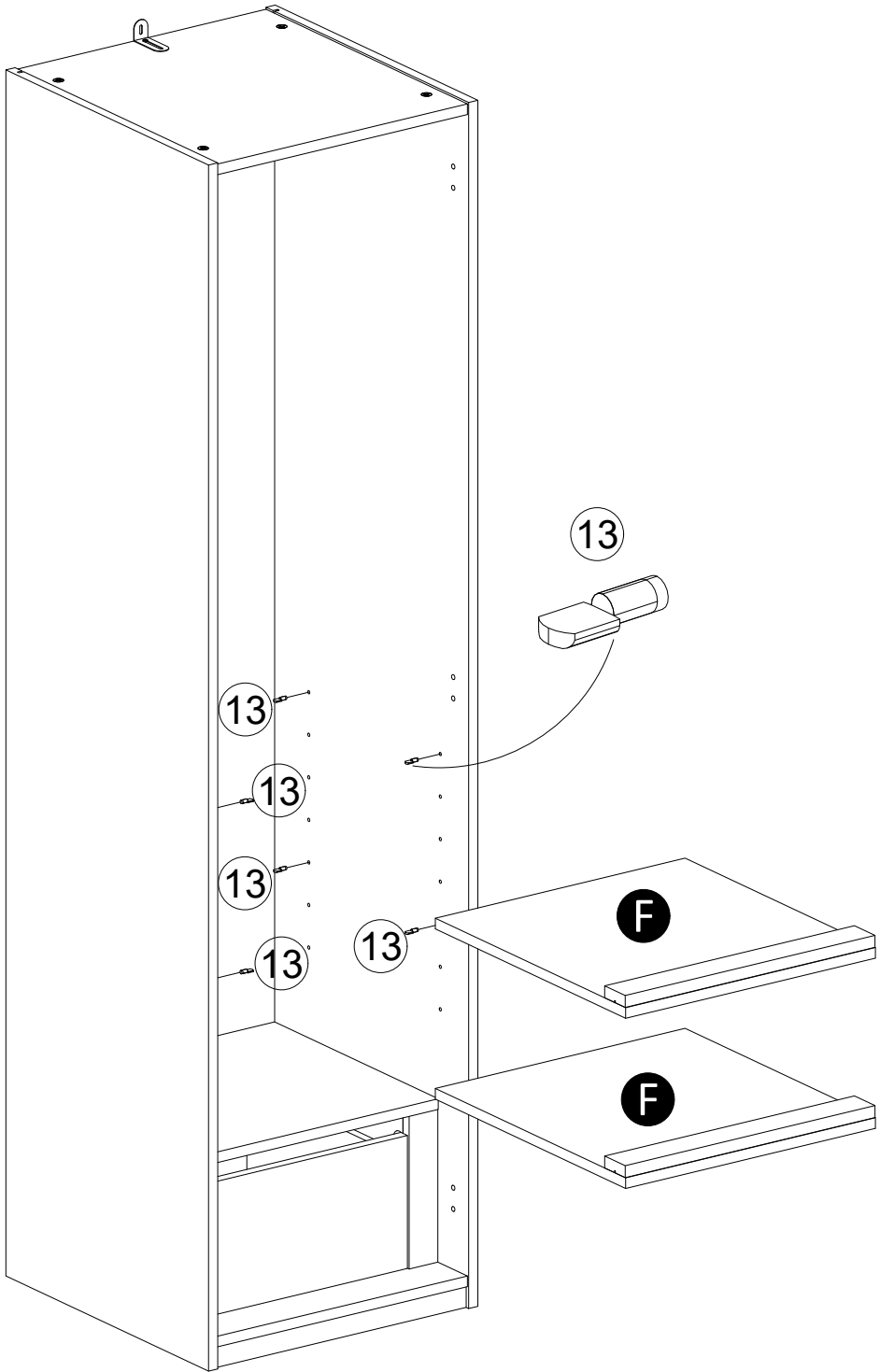
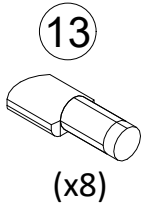

STEP 29

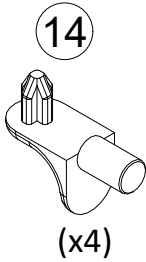
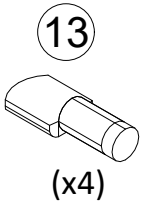

Note:

The Adjustable Shelves can be installed in your unit at an angle. Replace the two Shelf Supports (13) in the back with two Shelf Supports (14) and place them in the next hole up. Next place the pointed pin of the Shelf Support (14) into the two holes in the back of the Adjustable Shelf.

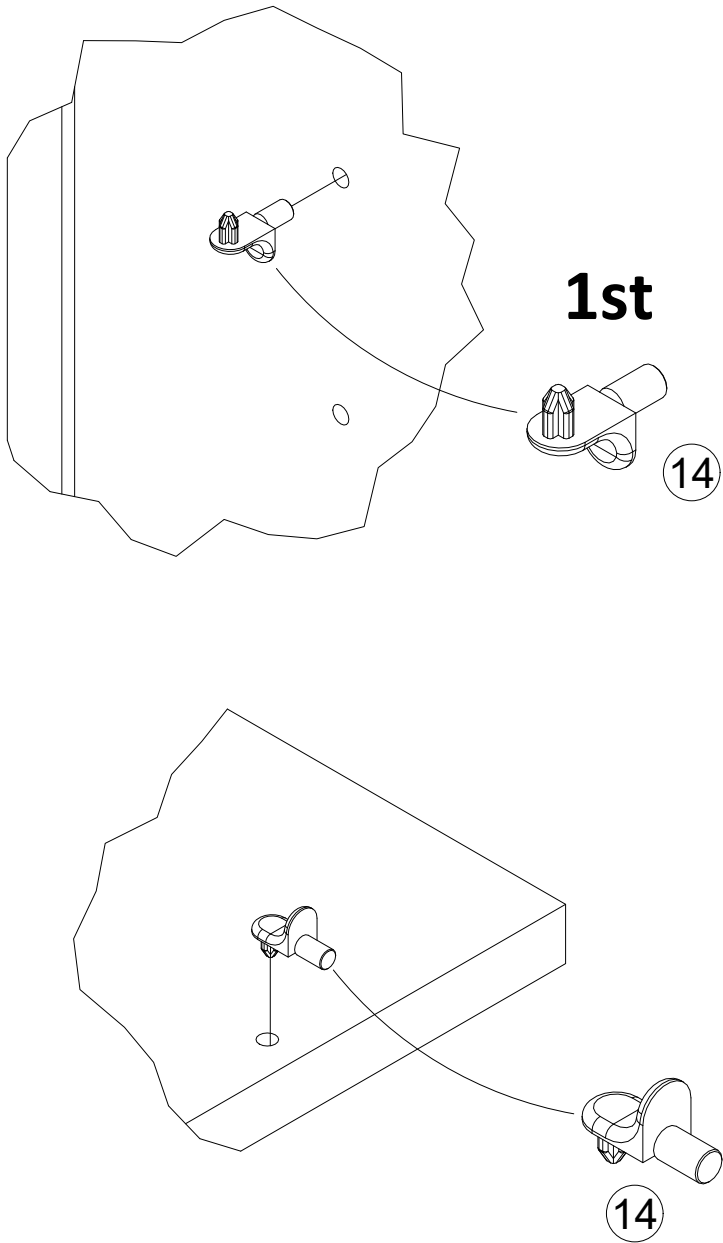
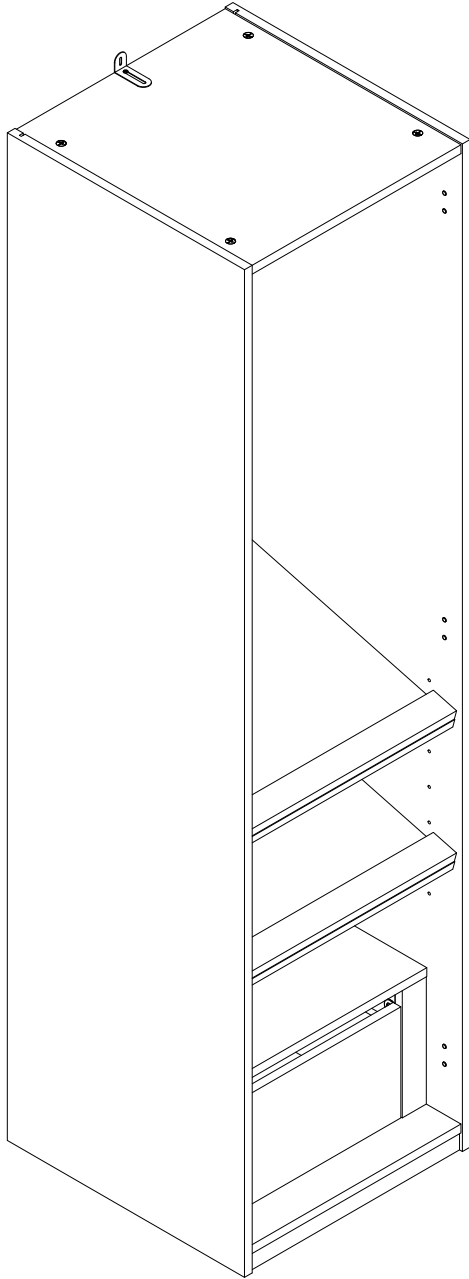

STEP 30

If you are not using optional door kit (3074341EBL) please insert provided hole plugs to fill hinge holes in left and right side panels (A&B).

12



(x12)

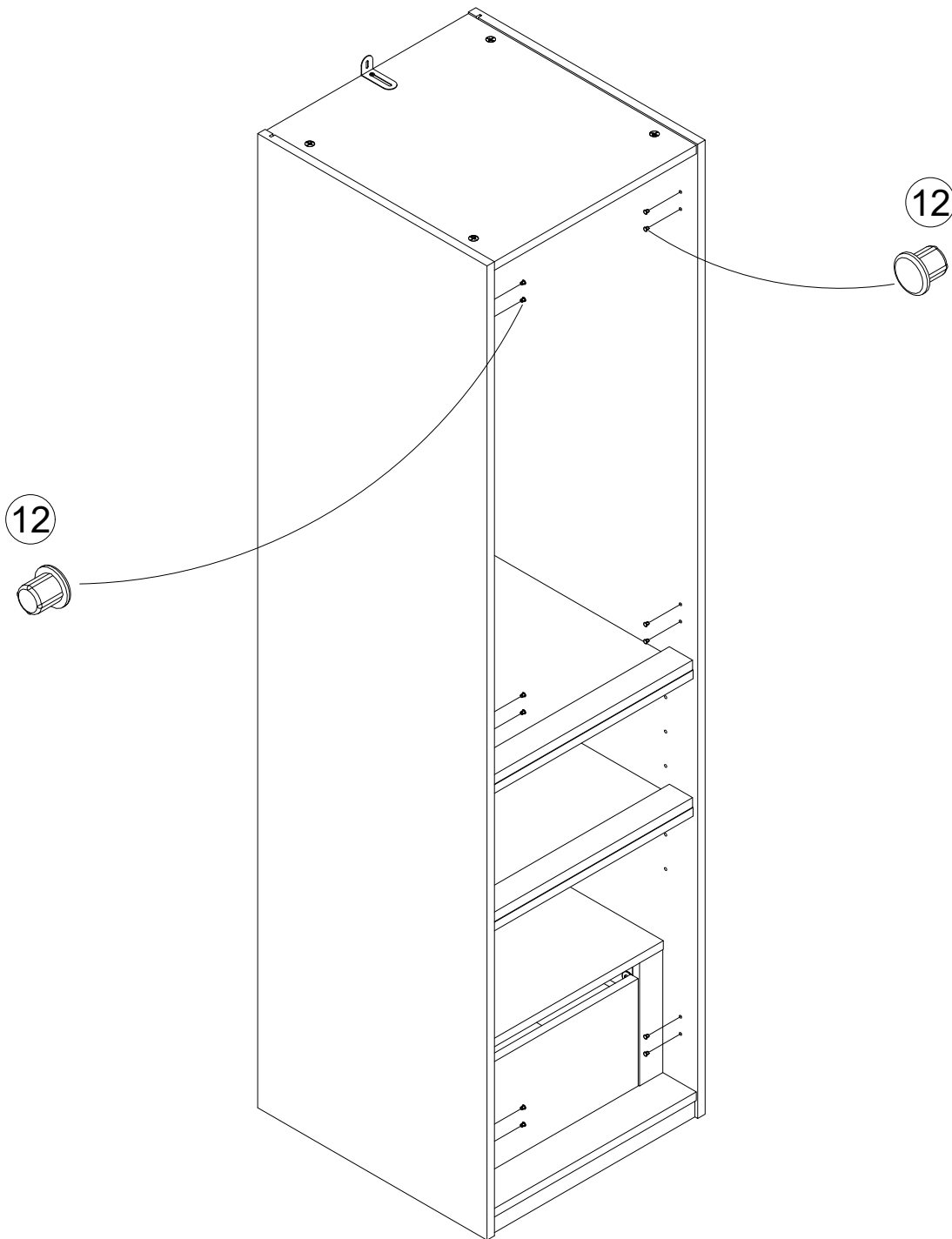

Maximum Loads

This unit has been designed to support the maximum loads shown. Exceeding these load limits could cause sagging, instability, product collapse, and/or serious injury.

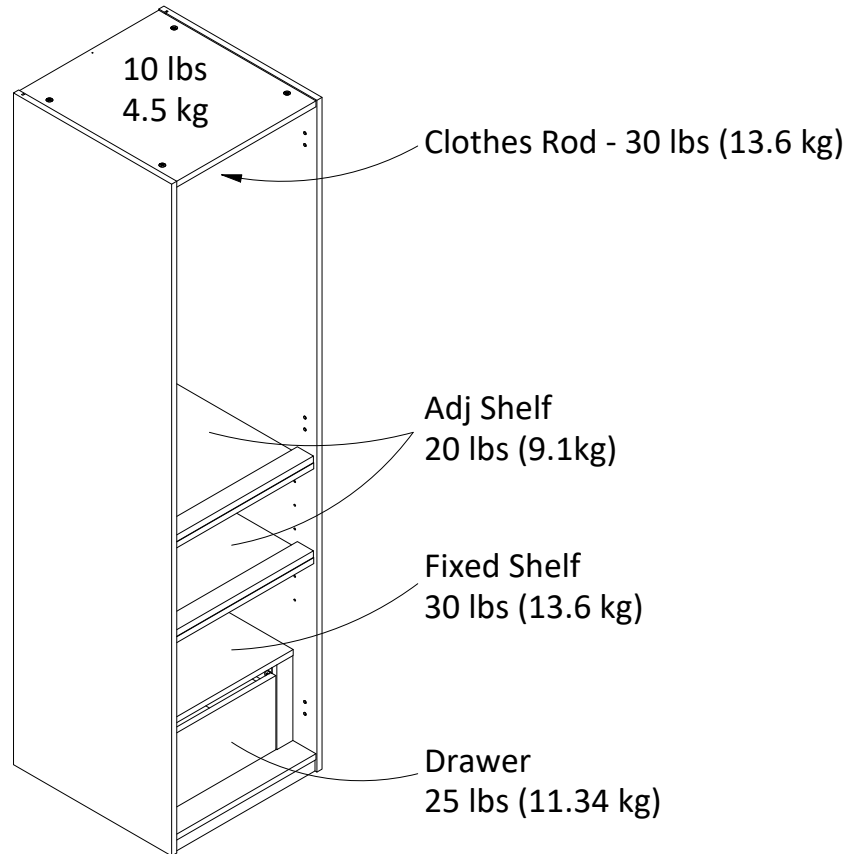

Warning: Risk of injury to persons - do not place a television on this furniture. This furniture is not approved for use with a television.

Certificate of Conformity

1. This certificate applies to the Dorel Home Furnishings, Inc. product identified by this instruction manual.
2. This certificate applies to compliance of this product with the CPSC Ban on Lead-Containing Paint (16 CFR 1303).
3. This product is distributed by: Dorel Home Furnishings, Inc.
410 East First Street South
Wright City, MO 63390
636-745-3351
4. Site of Manufacture: Tiffin OH
5. See front page of instruction manual for date of manufacture.

Register your product to receive the following:



- * New trend details - sneak peek on what's new
- * Surveys - have a voice within our community
- * Exclusive deals and discount codes
- * Quick and easy replacement part service

To register your product, visit ameriwoodhome.com

5 Star Rating



Visit your local retailer's website, rate your purchased product and leave us some feedback!

We would like to extend a big "Thank You" to all of our customers for taking the time to assemble this Ameriwood Home product, and to give us your valuable feedback.

*Thank
You!*

Cubierta Delantera

Este libro de instrucciones contiene información **IMPORTANTE** de seguridad. Por favor lea y manténgalo para referencia en el futuro.

No Regrese este producto! Comuníquese con nuestro amigoso equipo de servicio al cliente para obtener ayuda.

Llámenos al: 1-800-489-3351 (Gratis)

Visitar: www.ameriwoodhome.com

PRECAUCION

Este mueble puede volcarse y causar graves heridas y/o muerte.

Anclar el mueble a un poste de madera en la pared (si esto se requiere).

No Permita que los niños monten el mueble.

Mantenga los artículos más pesados en los cajones de abajo.

Consejos Útiles (página 2)

- Abra su artículo en el área donde usted planea utilizarlo para evitar levantar y moverlo menos
- Identificar, ordenar y contar las piezas antes de intentar ensamblar
- Las clavijas de compresión se golpean con un martillo
- Las diapositivas están marcadas con una R (derecha) y L (izquierda) para la colocación correcta
- Asegúrese de que siempre este el punto localizado en la parte superior de bloqueador de leva este volteado hacia borde exterior
- Utilizar todos los clavos para el panel de atrás y distribuirlos por igual
- El panel de atrás debe utilizarse para asegurarse de que la unidad quede fija y firme
- No use químicas fuertes ni limpiadores abrasivos en este artículo
- Nunca empuje, tire ni arrastre los muebles

Antes de Que Empieces (página 3)

- Lea cuidadosamente cada paso y siga el orden correcto
- Separar y contar todas sus piezas y hardware
- Dése suficiente espacio para el proceso de ensamble
- Tenga las siguientes herramientas: destornillador de cabeza plana, #2 cabeza Phillips
Destornillador y martillo
- Precaución: Si usa un taladro electrónico o un destornillador eléctrico para atornillar, por favor asegúrese que deje de atornillar cuando el tornillo este apretado. Fallar hacer esto puede causar barrer el tornillo.

Sistema de fijar el bloqueo de leva (página 3)

Esta sistema de fijar el bloqueo de leva sera usado en todo el proceso ensamble.

Página 5-Identificación del tablero

Tamaño no real

Panel lateral izquierdo
Panel lateral derecho
Montante interior izquierdo
Montante interior derecho
Parte superior
Estante ajustable
Estante ajustable
Estante fijo
Parte inferior
Larguero superior trasero
Larguero inferior trasero
Raíl vertical
Kick

Página 6- Identificación del tablero

Tamaño no real

Lado izquierdo del cajón
Lado derecho del cajón
Cajón Falso Frente
Parte trasera del cajón
Frente del cajón
Fondo cajón
Panel trasero

Página 10-Lista de piezas

Información sobre las guías

Su unidad viene con cuatro (4) guías de cajón. Para cada guía, extienda la guía como se muestra y presione la palanca de liberación para retirar la guía interior. Guarde la guía interior para más tarde. Para los pasos 3 y 4, fijará la guía a los paneles de la parte posterior de la guía. Mientras desliza la guía central, localice los orificios de los paneles con los orificios de acceso de la guía central y fíjelos con tornillos.

*Palanca de apertura

*Guía central

*Guía exterior

*Guía interior

*Utilice estos agujeros para fijar la guía exterior a los paneles.

Paso 3-Utilice estos agujeros

Paso 4-Utilice estos agujeros

Página 8-Lista de piezas

Tamaño real

Cierre de leva
Taco de madera
Tornillo Confirmat
Carcasa del conector
Perno conector
Tornillo 1-3/4
Clavo
Cuña
Tornillo 7/16
Tornillo 7/16
Tapón
Soporte de estante
Soporte de estante
Tornillo 1
Sujetador
Soporte de varilla

Página 9-Lista de piezas

Tamaño no real

Guía del cajón
Barra de ropa
Soporte de cajón
Kit de anclaje de pared

Paso 10-Gire en el sentido de las agujas del reloj para bloquear en su lugar.

Paso 14-Gire en el sentido de las agujas del reloj para bloquear en su lugar.

Paso 16-Gire en el sentido de las agujas del reloj para bloquear en su lugar.

Paso 17

¡IMPORTANTE! EL PANEL TRASERO ES UNA PARTE ESTRUCTURAL DE ESTA UNIDAD Y DEBE INSTALARSE CORRECTAMENTE.

Con la ayuda de otra persona, gire la unidad sobre su lado frontal. Despliegue el panel trasero. Con el lado sin cortar hacia abajo, deslice el panel posterior en la ranura de los paneles izquierdo y derecho (A y B), asentándolo en la ranura de la parte superior (E). Tenga en cuenta que el panel trasero quedará debajo de los soportes.

Paso 18

Coloque la cuña en el panel trasero y deslice el borde dentro de la ranura. Apriete el tornillo para asegurar en su lugar.

Paso 19 - wall mounting step

Para mampostería, concreto u otro tipo de paredes:

Acude a tu ferretería local para obtener los anclajes adecuados para fijar de forma segura el soporte de seguridad.

IMPORTANTE: ESTA UNIDAD DEBE ASEGURARSE A UNA PARED PARA EVITAR QUE SE VUELQUE. SIGUE ESTAS INSTRUCCIONES PARA INSTALAR EL SOPORTE DE SEGURIDAD ANTICAÍDA QUE SE PROPORCIONA JUNTO CON ESTE PRODUCTO.

ADVERTENCIA

Un mueble al volcarse puede provocar heridas por aplastamiento que pueden resultar graves o mortales.

Para prevenir que un mueble se vuelque:

- * Instala el dispositivo contra caídas que se proporciona
- * Coloca los artículos más pesados en los cajones de más abajo
- * A menos que esté específicamente diseñado para tal fin, no coloques televisiones ni ningún otro objeto pesado sobre este mueble
- * Nunca permitas que los niños se suban o cuelguen de los cajones, puertas o repisas.
- * Nunca abras más de un cajón a la vez

El uso de los dispositivos contra caídas puede reducir, pero no eliminar por completo el riesgo de que el mueble se vuelque.

OPCIÓN 1: acoplado a un travesaño de la pared (método recomendado)

Ubica un travesaño en la pared utilizando un localizador de travesaños. Coloca tu unidad contra la pared, con el soporte de seguridad alineado en ese lugar. Para facilitar la entrada del tornillo, puedes perforar un agujero guía de 1/8" (3 mm) de diámetro a través del soporte de seguridad hasta llegar al travesaño. Introduce el tornillo en el travesaño de la pared a través del soporte de seguridad. Aprieta el tornillo que no apretaste completamente en el paso 5.

OPCIÓN 2: acoplado a un panel de pared

Coloca tu unidad en el lugar deseado contra una pared y marca la pared a través del soporte de seguridad, luego retira tu unidad hacia un lado. Perfora un agujero de 3/16" de diámetro (5 mm) en el tablero de la pared. Golpea el anclaje de pared para introducirlo en el agujero hasta que quede a ras. Vuelve a colocar tu unidad en su lugar y sujeta el soporte de pared al anclaje de pared con el tornillo. Aprieta el tornillo que no apretaste completamente en el paso 10.

Paso 24

*Este borde contra el frente del cajón.

*Utilice estos agujeros

Paso 25

Instale los cajones encajando las guías interiores (fijadas a los laterales del cajón) con las guías exteriores fijadas a los montantes interiores izquierdo y derecho. Empuje hacia dentro hasta que la palanca de plástico encaje en la guía exterior.

*Guía exterior

*Guía interior

Paso 26-Coloque la varilla del armario en el soporte de la varilla.

Paso 29

Nota: Los estantes ajustables se pueden instalar en su unidad en ángulo. Reemplace los dos Soportes de Repisa (13) en la parte posterior con dos Soportes de Repisa (14) y colóquelos en el siguiente agujero hacia arriba. A continuación, coloque el pasador puntiagudo del soporte del estante (14) en los dos agujeros de la parte posterior del estante ajustable.

Paso 30

Si no está utilizando el kit de puerta opcional (3074341EBL), inserte los tapones de orificio suministrados para rellenar los orificios de las bisagras en los paneles laterales izquierdo y derecho (A y B).

Página 41- **weight limit page**

CARGA MAXIMA

Esta unidad ha sido diseñada para soportar la carga máxima anotada. El exceder estos límites puede causar inestabilidad, colapsarse y/o causar serias lesiones.

ADVERTENCIA: Riesgo de lesiones a las personas - no coloque un televisor sobre muebles. Este mueble no está aprobado para su uso con un televisor.

Página 42

Registre su producto para recibir lo siguiente:

- * Detalles de nuevas tendencias - Vistazo a lo nuevo
- * Encuestas - alec su voz entre su comunidad
- * Códigos de ofertas y descuentos exclusivos
- * Fácil y rápido servicio de partes de remplace

Para registrar su producto, visite ameriwoodhome.com

Clasificación de 5 estrellas

Visite el sitio web de su tienda local, califique su comprado y denos sus comentarios!

Nos gustaría enviar un gran "Agradecimiento" a todos nuestros clientes por tomarse el tiempo de ensamblar este producto de Ameriwood Home, y por darnos sus valiosos comentarios.

Gracias

Couverture Avant

CE LIVRET D'INSTRUCTION CONTIENT DES INFORMATIONS **IMPORTANTES** SUR LA SÉCURITÉ. VEUILLEZ LIRE ET GARDER POUR UNE RÉFÉRENCE FUTURE

Ne retournez pas ce produit! Contactez notre équipe de service à la clientèle amicale d'abord pour obtenir de l'aide.

Appelez-nous: 1-800-489-3351 (sans frais)

Visitez: www.ameriwoodhome.com

ATTENTION

Le meuble peut basculer et causer des blessures graves ou la mort.

Ancrer le meuble à une planche murale dans le mur (si indiqué).

Ne laissez pas les enfants grimper sur le meuble.

Placez les articles lourds sur les étagères ou dans les tiroirs inférieurs.

Astuces Utiles (page 2)

-Ouvrez votre article dans la zone que vous prévoyez de le garder pour moins de levage lourd

-Identifier, trier et compter les pièces avant d'essayer d'assembler

-Les goujons de compression sont taraudés avec un Marteau

-Les glissières sont marquées d'un R (droit) et d'un L (gauche) pour un bon placement

-Assurez-vous toujours de faire face la pointe situé sur le haut de la Serrure de Came vers le bord extérieur

-Utiliser tous les clous fournis pour le panneau arrière et les répartir également

-Le panneau arrière doit être utilisé pour vous assurer que votre appareil est robuste

-N'utilisez pas de produits chimiques agressifs ou de nettoyeurs abrasifs sur cet appareil

-Ne jamais pousser, tirer, ou faire glisser votre meuble

Avant de Commencer (page 3)

-Lisez attentivement chaque étape et suivez le bon ordre

-Séparez et comptez toutes vos pièces et matériaux

-Donnez-vous suffisamment de place pour l'assemblage

-Avoir les outils suivants: tournevis à tête plate, #2 tournevis Phillips, et Marteau

-Attention: Si vous utilisez une perceuse électrique ou un tournevis électrique pour visser, veillez à ralentir et arrêter lorsque la vis est bien serrée. Le non-respect de cette consigne peut endommager la vis.

Système de Fixation de Came (page 3)

Ce Système de Fixation de Came sera utilisé tout au long de l'assemblage

Page 5- Identification des panneaux

Pas la taille réelle

Panneau latéral gauche
Panneau latéral droit
Montant intérieur gauche
Montant intérieur droit
Haut
Étagère réglable
Rail d'étagère réglable
Étagère fixe
Bas
Limon supérieur arrière
Limon inférieur arrière
Rail vertical
Garde-pieds

Page 6- Identification des panneaux

Pas la taille réelle

Côté Tiroir Gauche
Côté Tiroir Droit
Fausse façade de tiroir
Tiroir arrière
Façade du tiroir
Fond de tiroir
Panneau arrière

Page 10- Liste des pièces

Informations sur les glissières

Votre unité est livrée avec quatre (4) glissières de tiroir. Pour chaque glissière, déployez la glissière comme indiqué et appuyez sur le levier de déverrouillage pour retirer la glissière intérieure. Mettez la glissière intérieure de côté pour plus tard. Pour la troisième et quatrième étape, vous fixerez la glissière aux panneaux à l'arrière de la glissière. Tout en faisant glisser la glissière du milieu, localisez les trous dans les panneaux avec les trous d'accès dans la glissière du milieu et fixez-les avec des vis.

*Lever de déverrouillage

*Glissière du milieu

*Glissière extérieure

*Glissière intérieure

*Utilisez ces trous pour fixer la glissière extérieure aux panneaux

Étape 3- utilisez ces trous

Étape 4- utilisez ces trou

Page 8- Liste des pièces

Taille réelle

Serrure batteuse
Cheville en bois
Vis d'assemblage Confirmat
Boîtier de connecteur
Boulon de connecteur
Vis 1-3/4 po
Clou
Cale
Vis 7/16 po
Vis 7/16 po
Bouchon de trou
Support d'étagère
Support d'étagère
Vis 1 po
Vis de fixation
Support de tige

Page 9- Liste des pièces

Pas la taille réelle

Glissière de tiroir
Tringle à vêtements
Renfort de tiroir
Kit d'ancrage au mur

Étape 10- tournez dans le sens des aiguilles d'une montre pour verrouiller en place.

Étape 14- tournez dans le sens des aiguilles d'une montre pour verrouiller en place.

Étape 16- Tournez dans le sens des aiguilles d'une montre pour verrouiller en place.

Étape 17

IMPORTANT! LE PANNEAU ARRIÈRE EST UNE PARTIE STRUCTURELLE DE CETTE UNITÉ ET DOIT ÊTRE INSTALLÉ CORRECTEMENT.

Avec l'aide d'une autre personne, retournez l'appareil sur sa face avant. Dépliez le panneau arrière. Avec le côté non coupé vers le bas, faites glisser le panneau arrière dans la rainure des panneaux gauche et droit (A et B) et dans la rainure du haut (E). Attention, le panneau arrière sera sous les supports.

Étape 18

Positionnez la cale sur le panneau arrière et faites glisser la lèvre dans la rainure. Serrez la vis pour la verrouiller en place

Étape 19 - **wall mounting step**

Pour la maçonnerie, le béton ou d'autres matériaux de mur :

Visiter votre quincaillerie locale pour obtenir des ancrs appropriées qui permettront de fixer solidement le support de sécurité.

IMPORTANT : CE MEUBLE DOIT ÊTRE SÉCURISÉ AU MUR POUR ÉVITER QU'IL NE BASCULE. SUIVRE CES INSTRUCTIONS POUR INSTALLER LE SUPPORT DE SÉCURITÉ ANTI-BASCULEMENT FOURNI AVEC CE PRODUIT.

AVERTISSEMENT

Des blessures graves ou mortelles peuvent se produire en cas de basculement des meubles.

Pour éviter le basculement :

- * Installer la pièce anti-basculement fournie
- * Placer les objets les plus lourds dans les tiroirs les plus bas
- * Sauf si spécifiquement conçu pour y être installé, ne pas poser de téléviseur ou d'autres objets lourds sur de ce produit
- * Ne jamais laisser enfants grimper ou s'accrocher sur les tiroirs, les portes ou les étagères
- * Ne jamais ouvrir plus d'un tiroir à la fois

L'utilisation des pièces anti-basculement peut uniquement réduire, mais pas éliminer le risque de basculement.

OPTION 1 : ancrage sur un colombage (méthode privilégiée)

Localisez un colombage dans le mur à l'aide d'un détecteur de colombage. Placez votre meuble contre le mur en maintenant le support de sécurité aligné au même endroit. Pour faciliter l'insertion de la vis, il est recommandé de percer un trou d'essai de 1/8 "de diamètre (3 mm) à travers le support de sécurité dans le colombage. Passer la vis à travers le support de sécurité pour l'insérer dans le colombage. Serrer la vis qui n'a pas été complètement serrée à l'étape 10.

OPTION 2 : ancrage dans la cloison sèche

Positionnez votre meuble sur la zone ciblée contre un mur et faites une marque sur le mur à travers le support de sécurité, puis déplacez votre meuble de côté. Percez un trou de 3/16" de diamètre (5 mm) dans le panneau mural. Tapez sur l'ancre murale pour l'introduire dans le trou jusqu'à ce qu'il soit parfaitement aligné et installé. Placez votre meuble sur son emplacement et fixer le support mural à l'ancre murale avec la vis. Serrez la vis qui n'a pas été complètement serrée à l'étape 10.

Étape 24

*Ce bord contre la façade du tiroir.

*Utilisez ces trous

Étape 25

Installez les tiroirs en engageant les glissières intérieures (fixées aux côtés des tiroirs) avec les glissières extérieures fixées aux montants intérieurs gauche et droit. Poussez jusqu'à ce que le levier en plastique s'enclenche dans la glissière extérieure.

*Glissière extérieure

* Glissière intérieure

Étape 26 : placez la tringle de placard sur le support de tringle.

Étape 29

Remarque : les étagères réglables peuvent être installées dans votre unité en biais. Remplacez les deux supports d'étagère (13) à l'arrière par deux supports d'étagère (14) et placez-les dans le trou suivant. Placez ensuite la tige pointue du support d'étagère (14) dans les deux trous à l'arrière de l'étagère réglable.

Étape 30

Si vous n'utilisez pas le kit de porte en option (3074341EBL), veuillez insérer les bouchons fournis pour remplir les trous de charnière dans les panneaux latéraux gauche et droit (A et B).

Page 41 - **weight limit step**

CHARGES MAXIMALES

Ce meuble a été conçu pour supporter les charges maximales indiquées. En excédant ces limites de charge, le meuble pourrait devenir instable, s'effondrer, et/ou causer des blessures graves.

AVERTISSEMENT : Risque de blessure corporelle - ne pas placer une télévision sur ce meuble. Ce meuble n'est pas approuvé pour une utilisation avec une télévision.

Page 42

Enregistrez votre produit pour recevoir les éléments suivantes:

- * Détails sur les nouvelles tendances - un aperçu sur les nouveautés
- * Sondages - avoir une voix au sein de notre communauté
- * Offres exclusives et codes promo
- * Service de pièces de rechange rapide et facile

Pour enregistrer votre produit, visitez ameriwoodhome.com

5 Étoiles

Visitez le site Web de votre détaillant local, évaluez votre produit acheté et laissez-nous quelques commentaires !

Nous tenons à offrir un grand "Merci" à tous nos clients pour avoir pris le temps d'assembler ce produit "Ameriwood Home", et de nous donner vos commentaires précieux.

Merci