

 **real**
living™

ALL WEATHER WICKER SWIVEL EGG CHAIR

ASSEMBLY INSTRUCTIONS

ITEM# : GBO24-612S

SKU# : 810670068

Need help? We are here for you! 1-888-733-8169 Toll Free

Or email us at customerservice_01@yeah.net, customerservice_02@yeah.net

customerservice_03@yeah.net

GENERAL BEST PRACTICES FOR ASSEMBLY:

- Read all instructions before starting.
- Clear a flat covered space to begin assembly.
 - Always best to do it with a friend.
- Note that hardware required is provided for every step.
 - Pay attention to orientation .
- Number of the hardware corresponds to its letter in the package.
 - Helpful hints provided along the way.

WARNINGS:

• Use the correct screws as indicated. All screws should be hand tightened until the complete piece is assembled (This will make the assembly process much easier). Once the piece is fully assembled, then go back and tighten all screws with provided tool.

- Keep all children and pets away from assembly area.

Children and pets should be supervised when they are in the area of the product construction.

- Keep assembly area at least 6 feet from any obstruction such as a fence, garage, house, overhanging branches, laundry line or electrical wires.

- Some parts may contain sharp edges. When assembling and using this product, basic safety precautions should always be followed to reduce the risk of personal injury and damage to the product. Please read all instructions before assembly and use.

- The chair is not to be used for standing purposes and will not function as a stool or step-ladder. Use on even surfaces only.

• The chair is used at weight of 250lb (113.6kg). Improper use of this product or failure to use as directed may result in injury. Not intended for commercial use.

MAINTENANCE :

- **STAIN RESISTANT CUSHIONS CARE — KEEP THE CUSHIONS IN STORAGE ON RAINY DAYS.**

- **SPILLS:** Immediately wipe up the spill using a white damp cloth. Repeat process if necessary until stain is gone. Allow cushions to air dry.

- **FABRIC CARE:** Hand wash cold, non-chlorine bleach when needed, lay flat to dry. Cool iron if necessary. Do not dry clean.

- **ALL WEATHER WICKER PRODUCT CARE**

Before using, clean the product completely with a soft dry towel. When not in use, wipe free of any dirt or loose objects, wash with a mild solution of soap and water, rinse thoroughly and dry completely. Do not use strong detergent or abrasive cleaners. Screws can loosen over a period of usage, please check the screws occasionally and re-tighten if necessary.

PARTS LIST

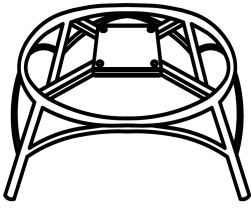

A
Base

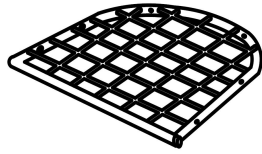

B
Seat Panel



C
Right Side Panel

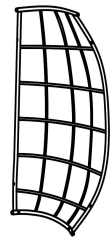

D
Back Panel

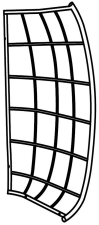

E
Left Side Panel



F
Top Panel

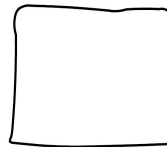

O
1PC Back Cushion

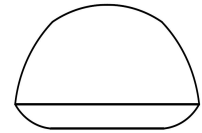

P
1PC Seat Cushion



Q
2PC Side Cushion

HARDWARE LIST



G
10PC Screw(M6x25mm)



H
28PC Washer



I
14PC Screw(M6x35mm)



J
4PC Connection Lock



K
2PC Allen Wrench



L
4PC Spring Washer



M
4PC Nut



N
1PC Open End Wrench

STEP 1

Assemble chair base (A) to seat panel (B) with 4 screws (I) , 8 washers (H), 4 spring washers (L) and 4 nuts (M) by using open end wrench (N). **Fully tighten 4 screws (I).**

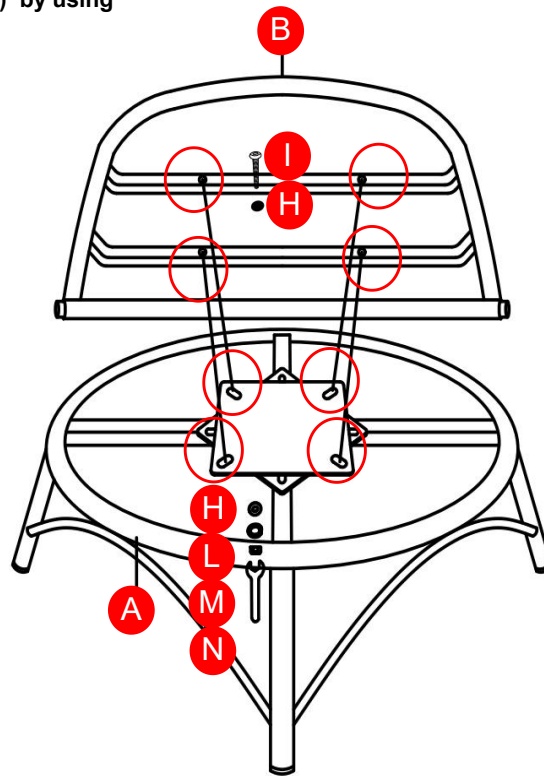

STEP 2

Assemble right side panel (C) to back panel (D) with 2 screws (I) , 2 screws (G) and 4 washers (H) by using allen wrench (K). Do not fully tighten all screws now.

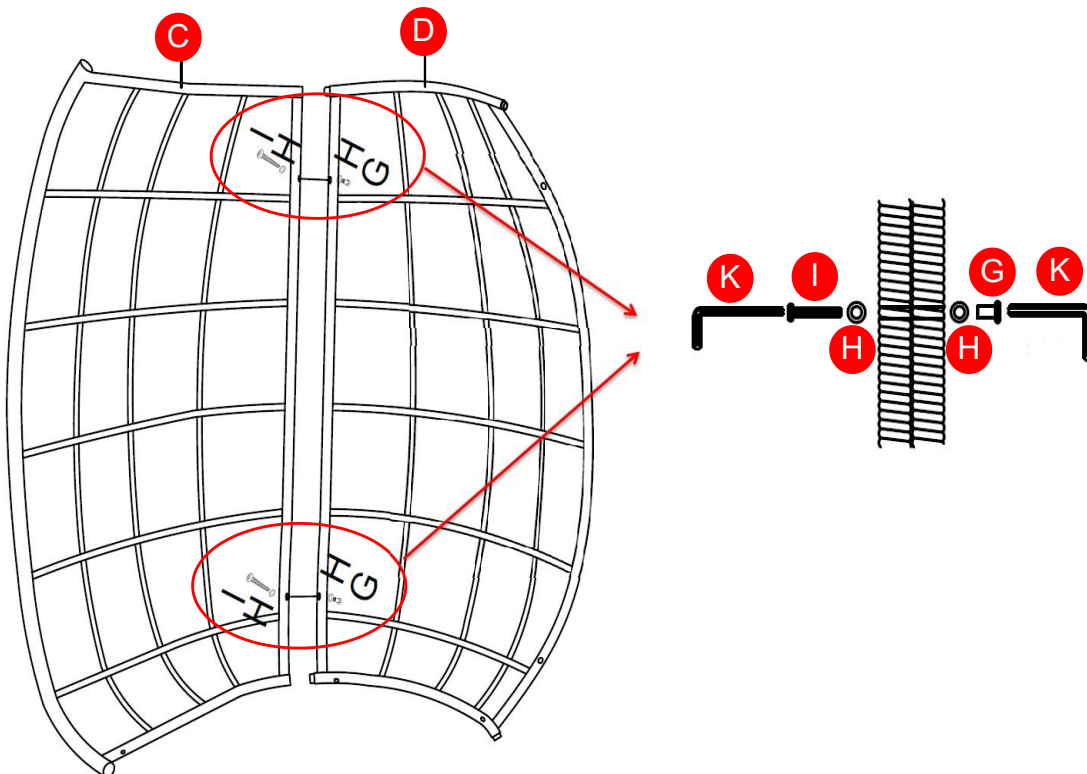

STEP 3

Assemble back panel (D) to left side panel (E) with 2 screws (I), 2 screws (G) and 4 washers (H) by using allen wrench (K). Do not fully tighten all screws now.

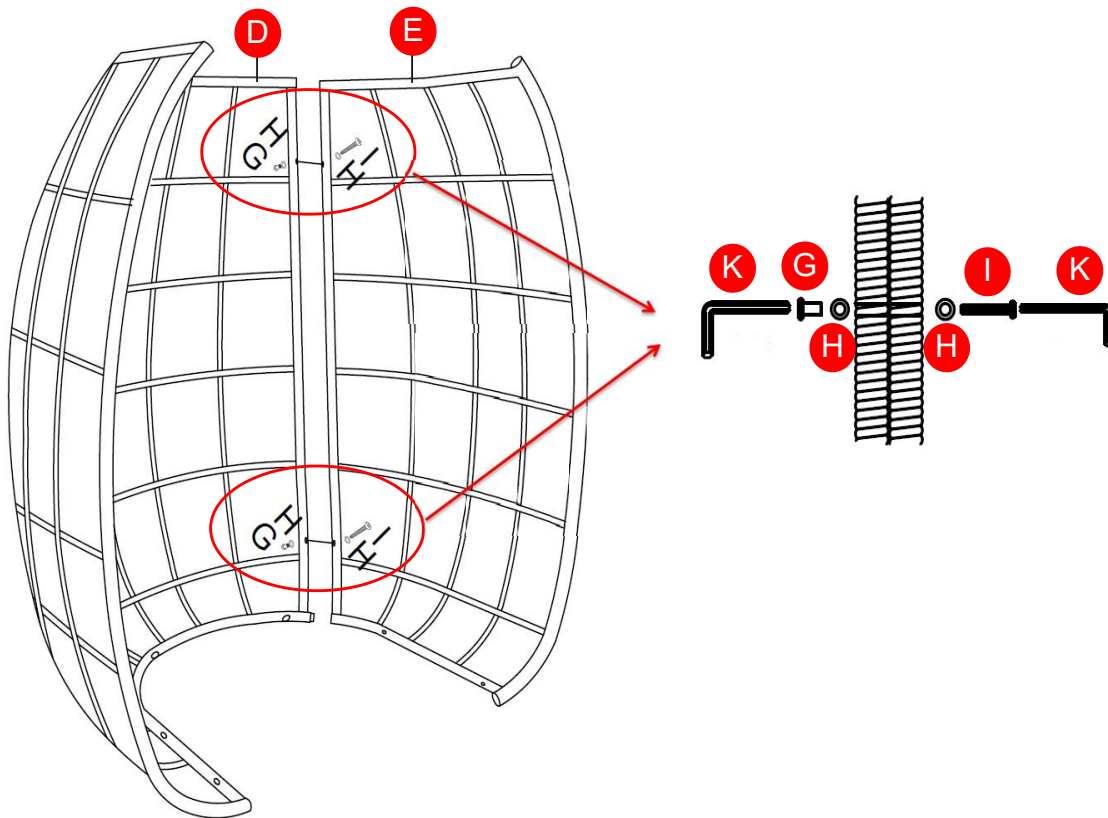

STEP 4

Assemble seat panel (B) to right side panel (C), back panel (D) and left side panel (E) with 6 screws (I), 6 screws (G) and 12 washers (H) by using allen wrench (K). Do not fully tighten all screws now.

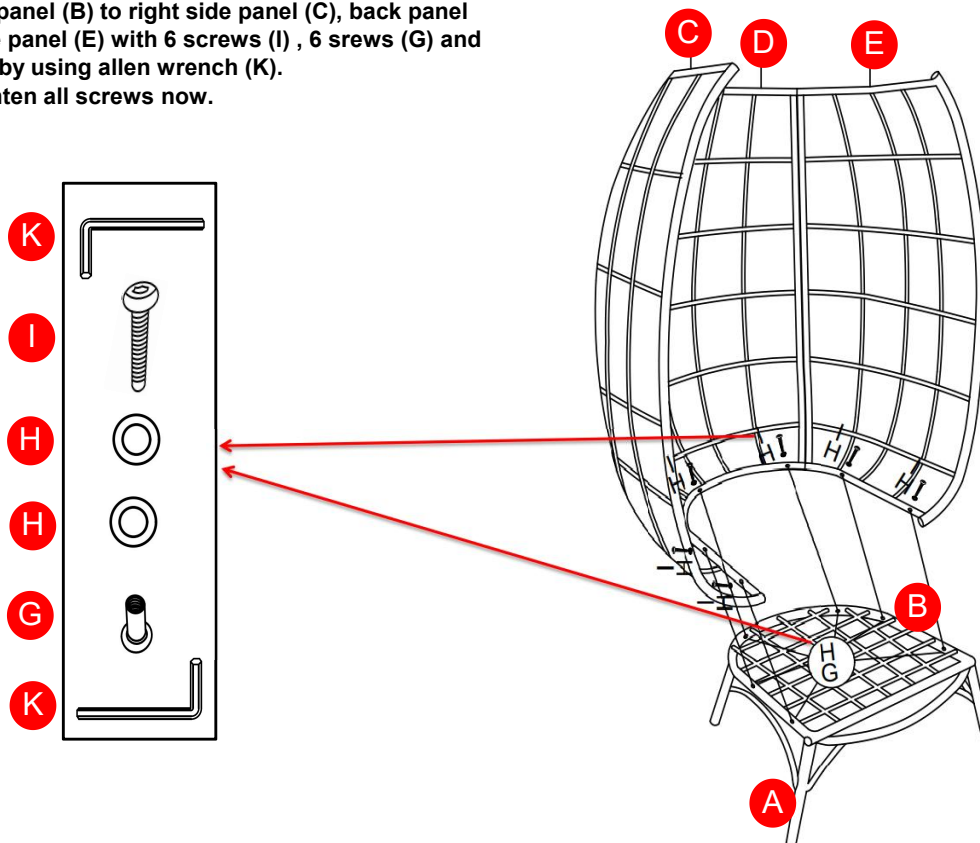

STEP 5

Secure top panel (F) to right side panel (C), left side panel (E) and back panel (D) with 4 connection locks (J) by hand. Do not fully tighten all screws now.

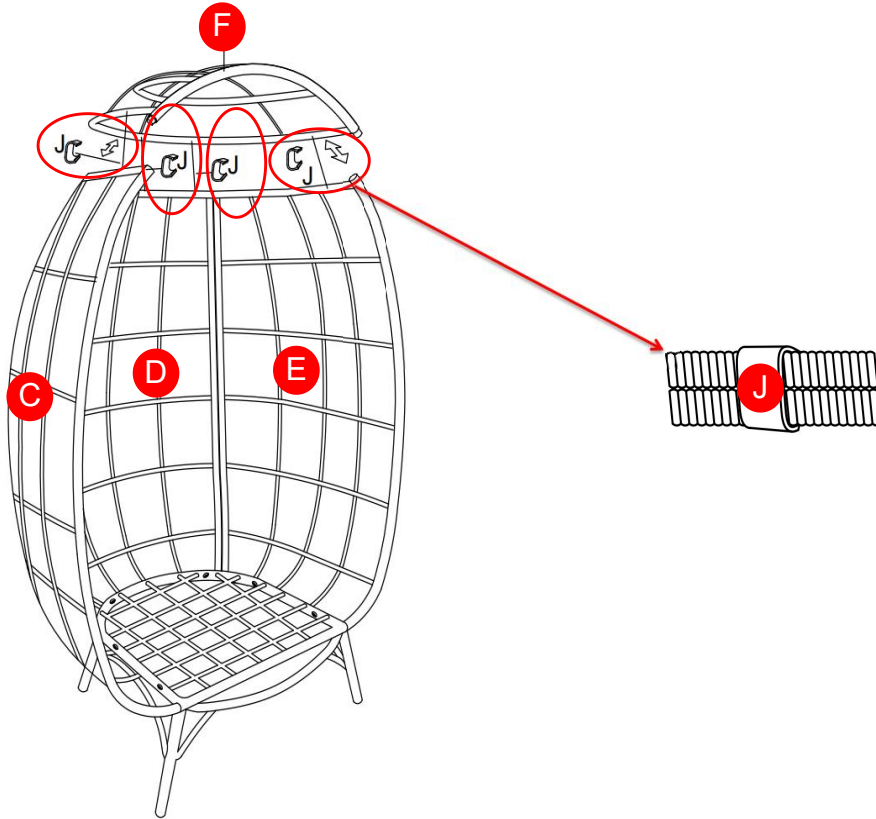

STEP 6

Fully tighten all screws, then put the cushions (O P Q) on the chair, finished!

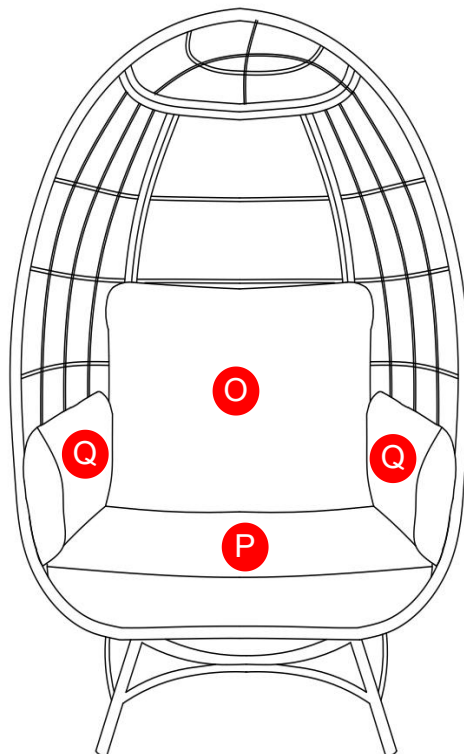

Warranty

One year limited warranty.

Proof of purchase (dated register receipt) is required for warranty claims.

It remains the customer's responsibility for freight and packing charges to and from the service center.