

BORDO COLLECTION

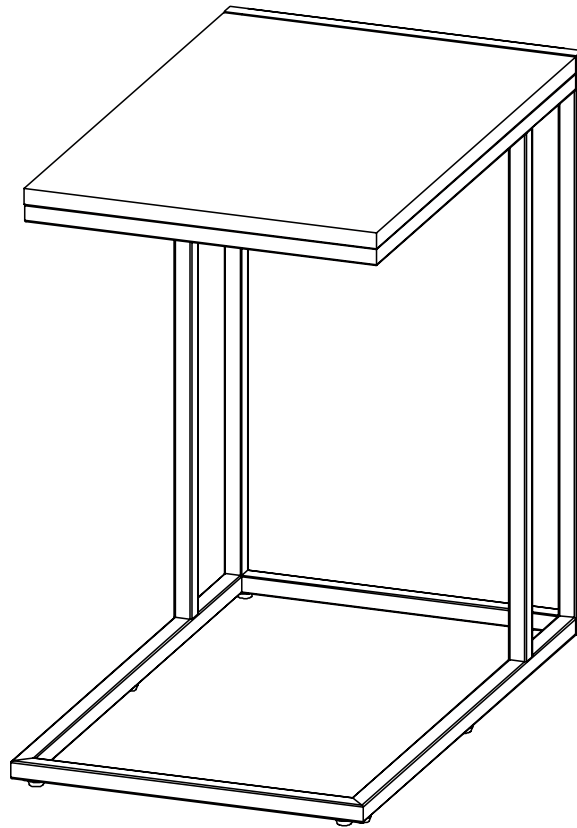

ASSEMBLY INSTRUCTIONS

ITEM#: 12101

SKU#: 810532848

**C SIDE TABLE
WITH CHARGING**

Need help? We are here for you!
www.biglots.com/help/contact-us

GENERAL BEST PRACTICES FOR ASSEMBLY:

- *Please read the assembly instructions prior to assembling this product.
- *Determine you have adequate space for assembly.
- *Assembly by two adults is recommended.
- *Assemble on soft surfaces to prevent damage to product finish.
- *Keep children away during assembly. This item contains small parts which can be swallowed by children.
- *Do not discard any of packaging until you have checked that you have all the parts and hardware.
- *Retain the assembly instructions for further reference.
- *The manufacturer will not accept responsibility for unauthorized repairs or modifications to this product.

WARNINGS:

- *Do not use power tools.
- *Remove all packaging material, make sure all parts are present before assembly.
- *Should this product become damaged, and/or components are broken or missing, DO NOT USE.
- *Do not sit or stand on the product, death or serious injury may occur.
- *Children should always be under direct adult supervision while using the product.

MAINTENANCE:

- *Wipe with a soft, dry cloth. To protect finish, avoid the use of water, chemicals and household cleaners.
- *Do not place objects which are more than 80 degrees Fahrenheit on the surface.
- *To prolong life of the product, keep the product away from direct sunlight.

HELPFUL HINTS

Before assembly, please remove all parts from the carton, verifying that you have the correct quantities, and read all the instructions.

You may need an assistant to finish these steps easily!

Please assemble on a soft flat surface such as carpet or a towel to avoid scratching table and assembly surfaces.

Please DO NOT fully tighten all bolts until frame assembly is complete.

PARTS LIST

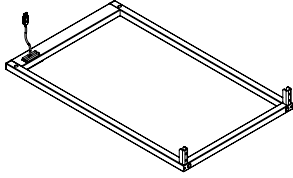

A

x1

Back Side Frame

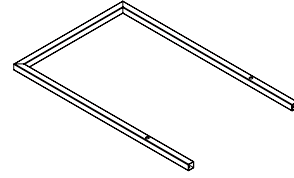

B

x1

Lower Support Frame

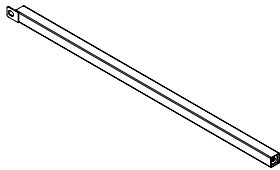

C

x2

Vertical Support Bars

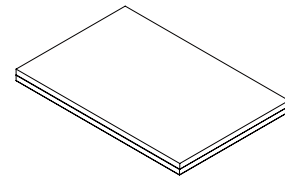

D

x1

Table Top

HARDWARE LIST



1

x6

Allen Bolt
1/4" x 1/2"

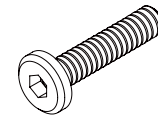

2

x4

Allen Bolt
1/4" x 1-1/2"



3

x8

Leveler
Ø3/4" x 3/5"



4

x1

Allen Key
Ø4mm x 2-1/4"

STEP 1

Attach Lower Support Frame (B) to the Back Side Frame (A) by using Allen Bolt (1) with an Allen Key (4) as shown in the diagram.

IMPORTANT

Do not fully tighten the bolts in this Step until the completion of Step 3.

Hardware needed:

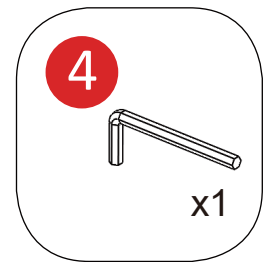

TOP

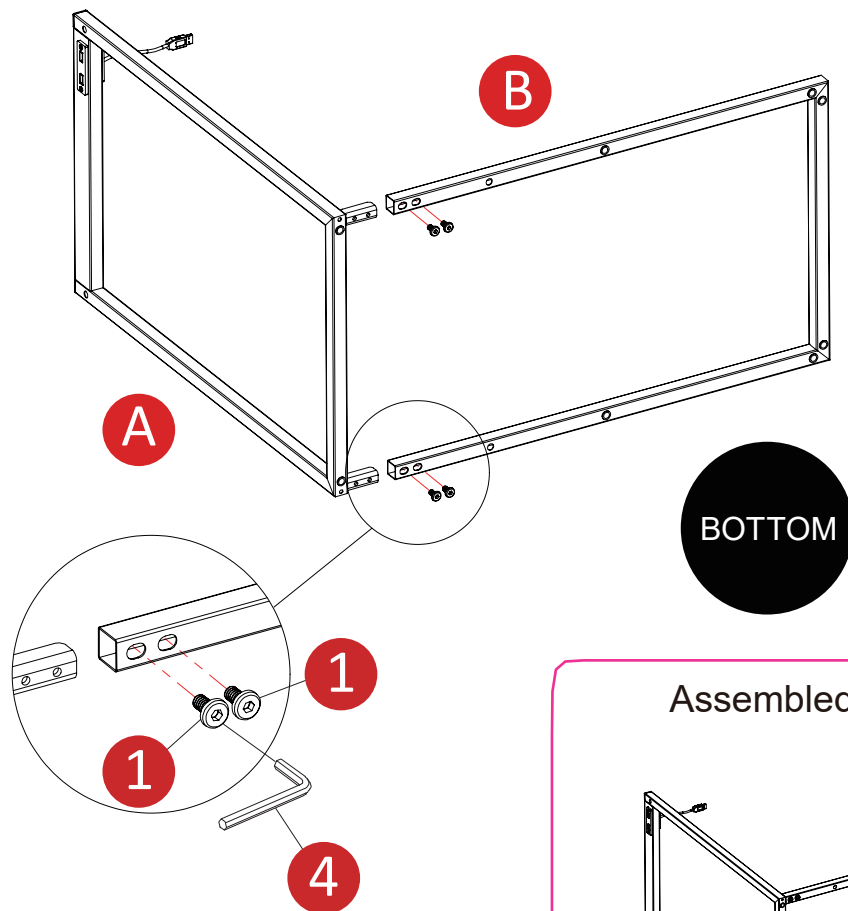

BOTTOM

Assembled View:

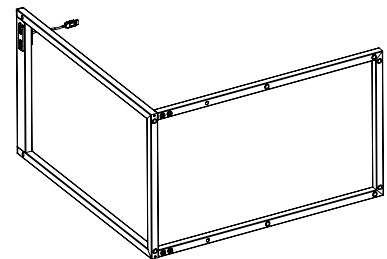

STEP 2

Attach Vertical Support Bar (C) to Lower Support Frame (B) by using Allen Bolt (2) with an Allen Key (4) as shown in the diagram.

IMPORTANT

Do not fully tighten the bolts in this Step until the completion of Step 3.

Hardware needed:

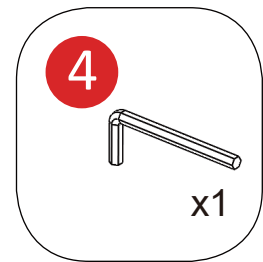
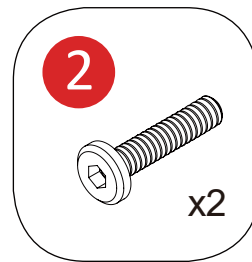

TOP

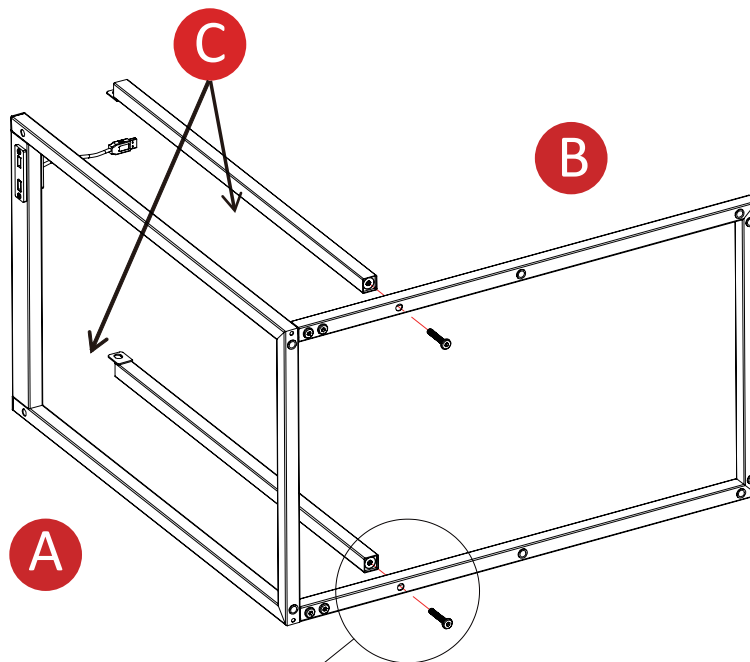

BOTTOM

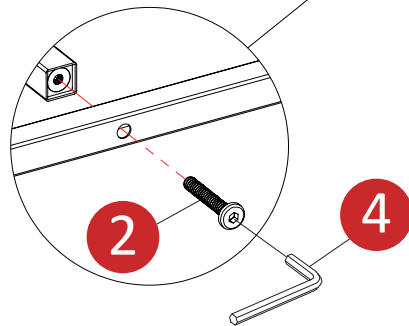

Assembled View:

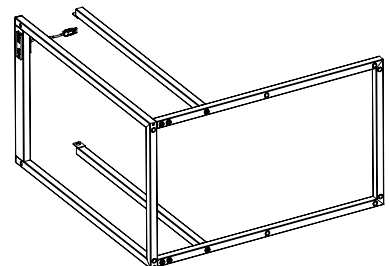

STEP 3

Place the Table Top (D) upside down on a padded, non-marring surface. Attach the assembled base frame (from step 2) to the Table Top (D) by using Allen Bolt (1), Allen Bolt (2) with an Allen Key (4) as shown in the diagram.

Fully tighten all Allen Bolts from Steps 1 through 3 at this time.

Hardware needed:

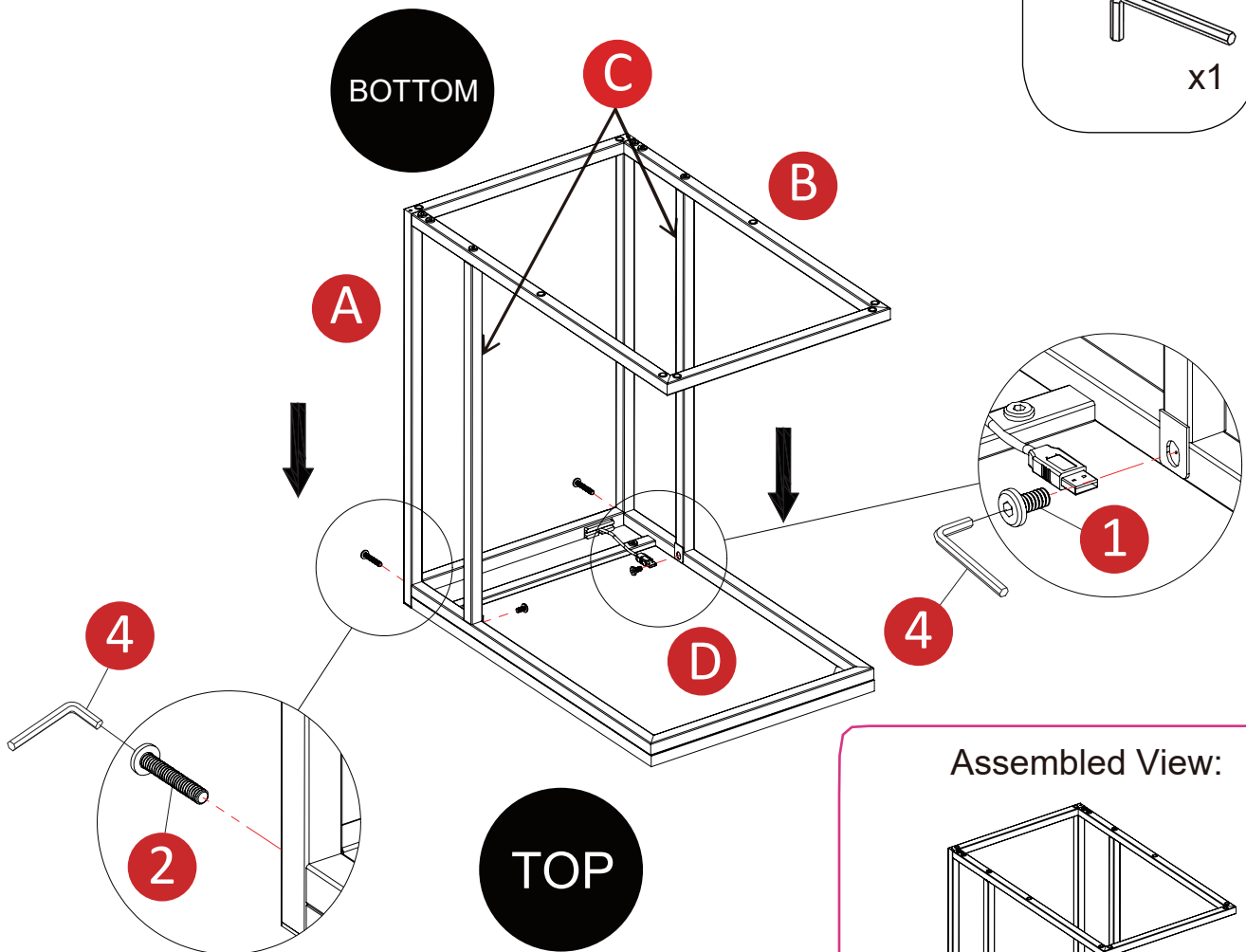
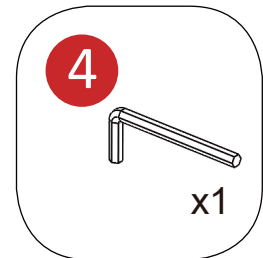
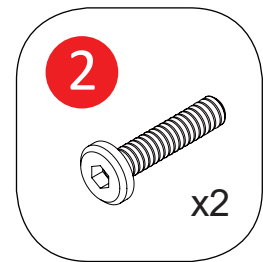

Assembled View:

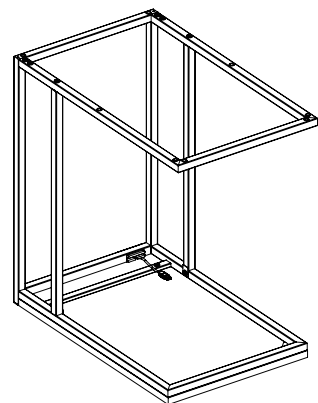

STEP 4

Insert Leveler (3) into the Lower Support Frame (B) and fully tighten. Return the table to the upright position. The levelers can be adjusted as needed so the Table is level and stable. All adjusters should be in full contact with the floor.

Hardware needed:

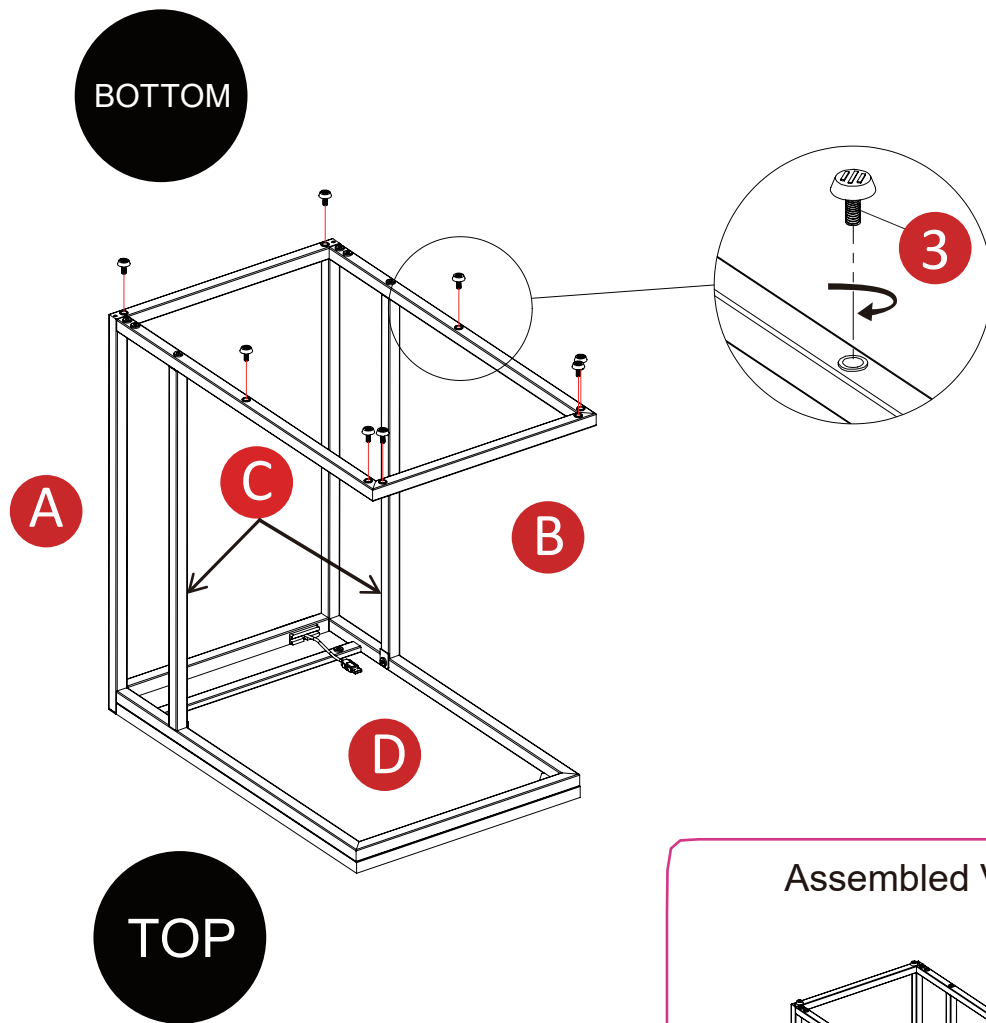
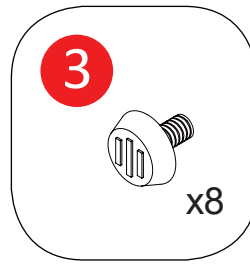

Assembled View:

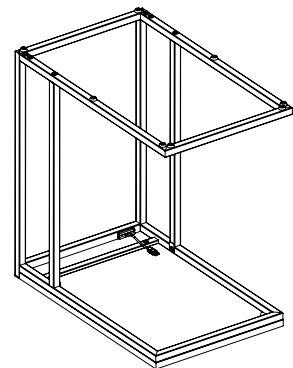

STEP 5

Assembly is now complete.

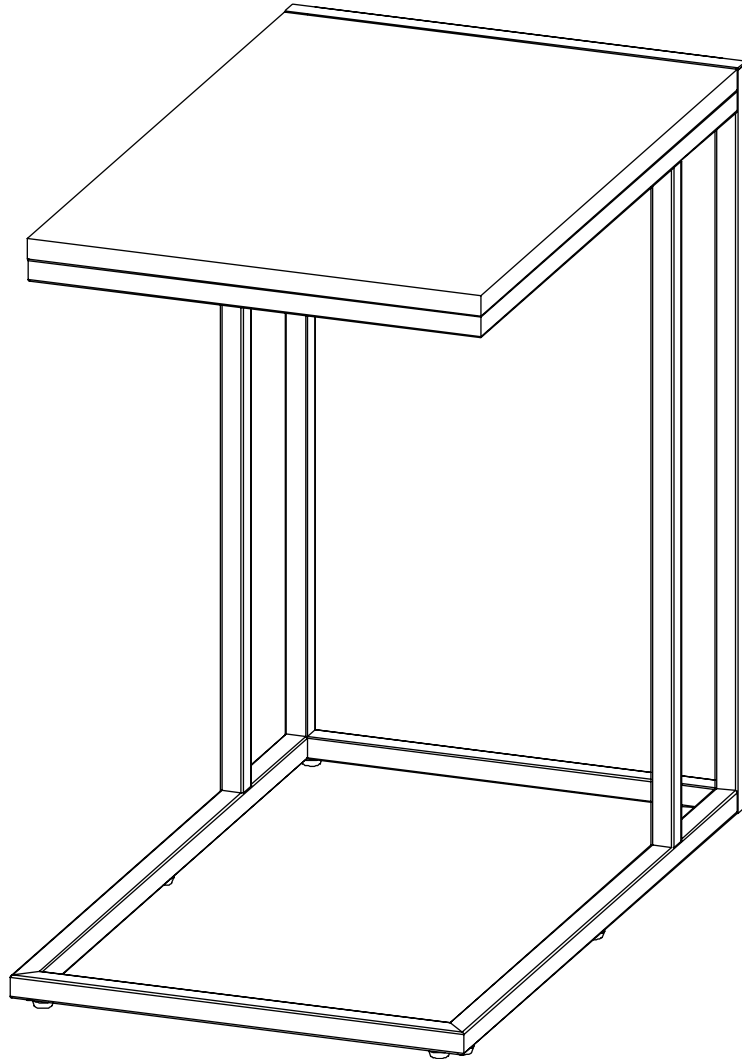

PRINTED IN VIETNAM