

HEIRLOOMS COLLECTION

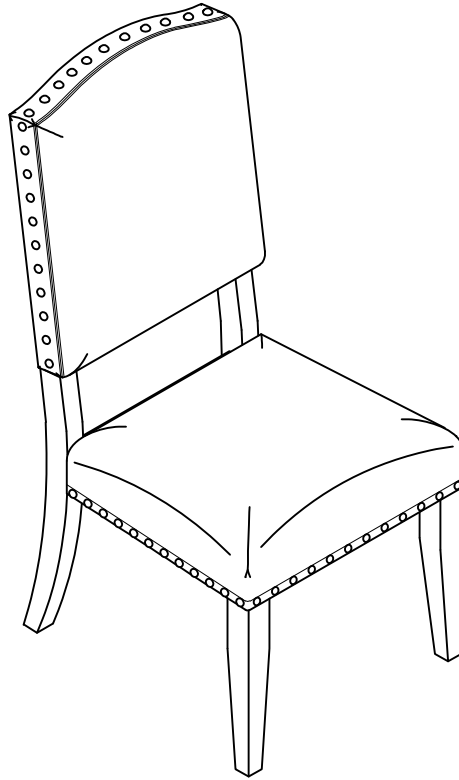

ASSEMBLY INSTRUCTION

ITEM#: HN500S
SKU#: 810511022

2PK UPHOLSTERED CHAIR

Need help? We are here for you! 1-888-400-8113 ext.1390 • Toll Free

GENERAL BEST PRACTICES FOR ASSEMBLY:

- * Please read the assembly instructions prior to assembling this product.
- * Determine you have adequate space for assembly.
- * Assembly by two adults is recommended.
- * Assemble on soft surfaces to prevent damage to product finish.
- * Keep children away during assembly. This item contains small parts which can be swallowed by children.
- * Do not discard any of the packaging until you have checked that you have all the parts and hardware.
- * Retain the assembly instructions for future reference.
- * The manufacturer will not accept responsibility for unauthorized repairs or modifications to this product.
- * This product is for residential use only, not for commercial use.

WARNINGS:

- * Should this product become damaged, and/or components are broken or missing, **DO NOT USE.**
- * The product will burn if left in contact with flame source.

MAINTENANCE:

- * Wipe with a damp cloth. Use Furniture polish or lemon oil on the wood as needed. Avoid prolonged exposure to moisture.
- * Do not scratch or chip the finish.
- * Do not put hot objects which are more than 80 degrees Fahrenheit directly on the surface.
- * Check bolts/screws periodically and tighten if necessary.
- * To prolong the life of product we recommend storage in a dry area when not in use or during austere weather conditions.

PARTS LIST

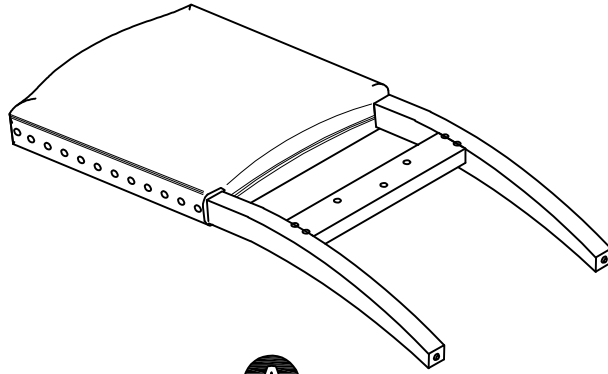

A

CHAIR BACK
x 2 pcs

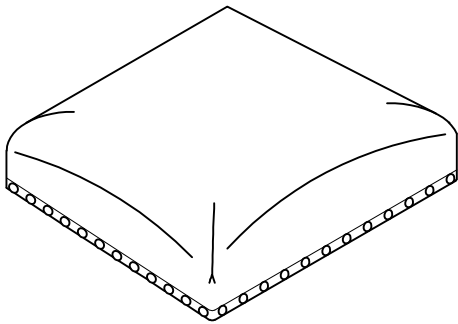

B

SEAT BOX W/SEAT CUSHION
x 2 pcs

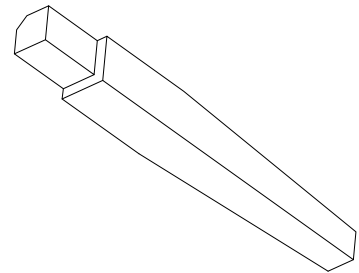

C

FRONT LEG
x 4 pcs

HARDWARE LIST



1

LONG BOLT x 8 pcs
 $\varnothing 1/4$ " x 75 mm



2

SHORT BOLT x 6 pcs
 $\varnothing 1/4$ " x 40 mm

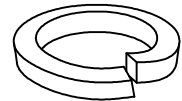

3

SPRING WASHER
x 22 pcs
 $\varnothing 5/16$ " x 13 mm

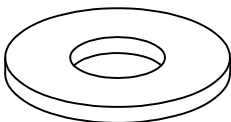

4

FLAT WASHER
x 22 pcs
 $\varnothing 5/16$ " x 19 mm



5

MEDIUM BOLT x 8 pcs
 $\varnothing 1/4$ " x 50 mm

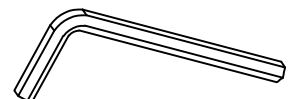

6

ALLEN KEY
x 1 pc
 $\varnothing 4$ mm

STEP 1

Place the Chair Back (A) facing up on a soft smooth surface. Attach the Seat Box W/Seat Cushion (B) to the Chair Back (A) by inserting Flat Washer (4), Spring Washer (3), Long Bolt (1) into the holes at the corner block of the Seat Cushion (B). Attach the back of the Seat Box W/Seat Cushion (B) to the Chair Back (A) by inserting Flat Washer (4), Spring Washer (3), Short Bolt (2) into the rear bar of the Seat Box W/Seat Cushion (B) using Allen Key (6). Do not fully tighten bolts in this step.

HARDWARE NEEDED:

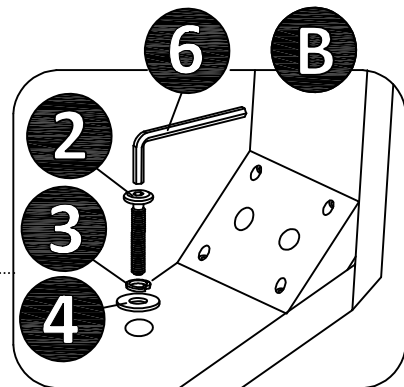
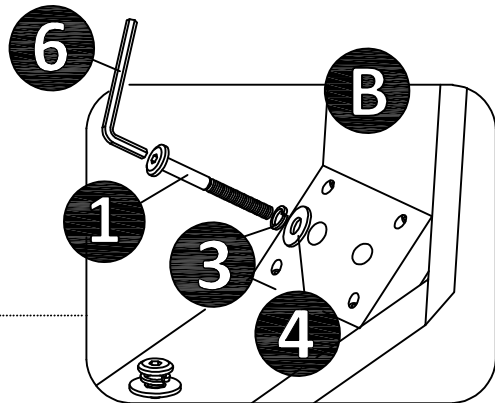
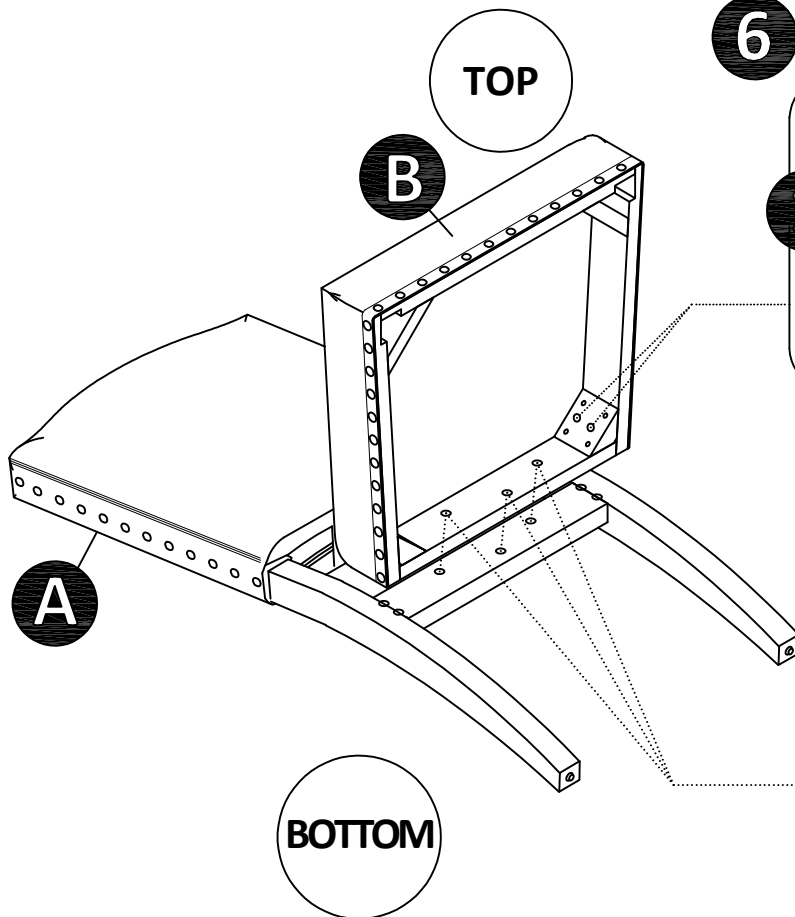
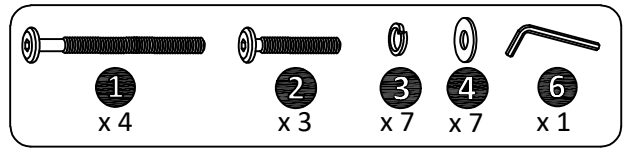

ASSEMBLED VIEW

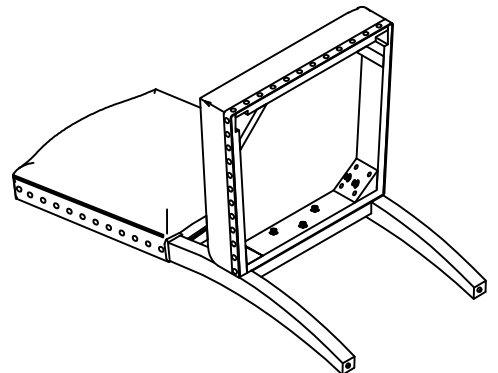

STEP 2

Attach the Front Leg (C) to the Seat Box W/Seat Cushion (B) with Flat Washer (4), Spring Washer (3) and Medium Bolt (5) using Allen Key (6).

HARDWARE NEEDED:

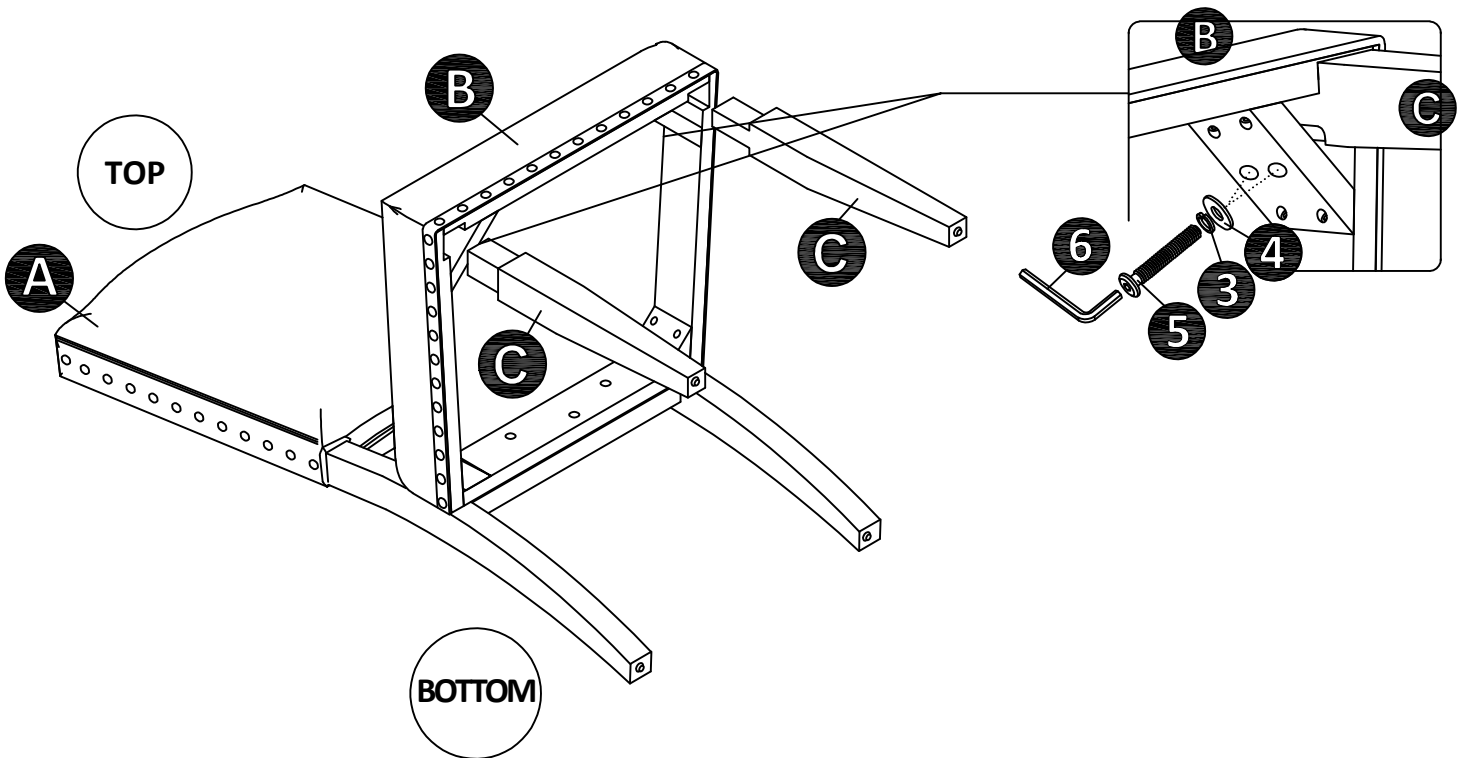
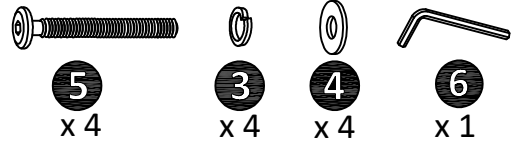

ASSEMBLED VIEW

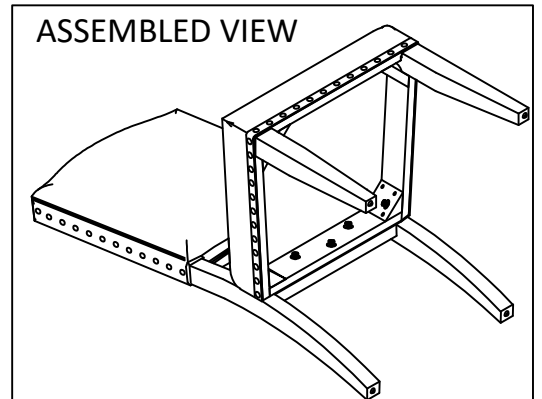

STEP 3

HARDWARE NEEDED:



6
x 1

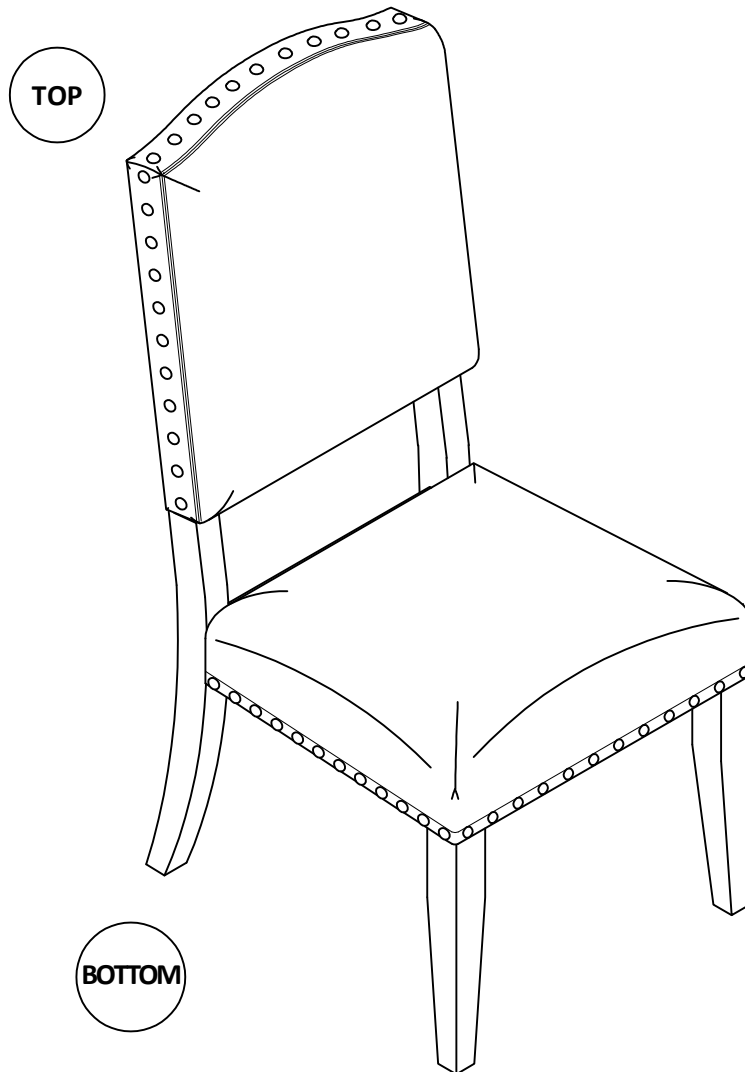

Carefully turn the assembled chair upright. Make sure the chair is level and fully tighten all bolts at this time using Allen Key (6). Repeat steps 1 through 3 to assemble any remaining chairs. Assembly is now complete.

PRINTED IN VIETNAM