

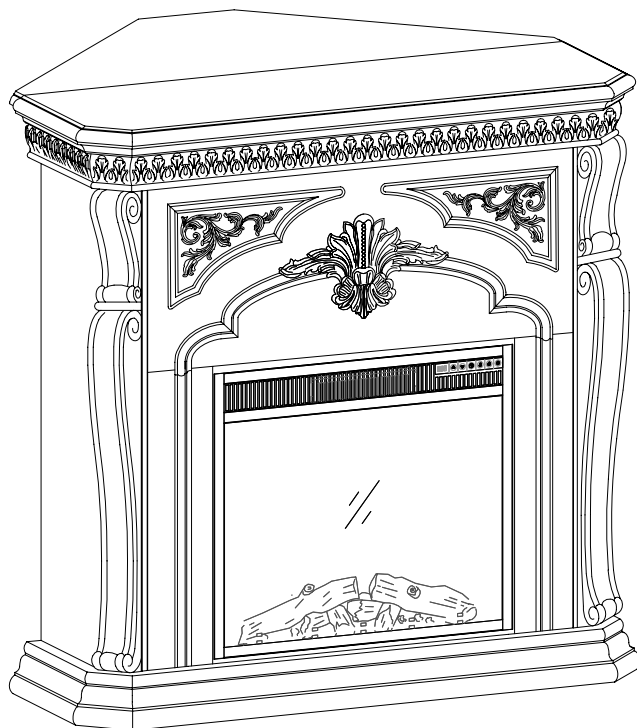

FEBO

FEBO (HK) INTERNATIONAL LIMITED



SKU # 810309487

ITEM # F15-C-030-007

42IN CORNER CHERRY FIREPLACE WITH 30IN INSERT

IMPORTANT INSTRUCTIONS

Please read Electric Fireplace User Manual before assembly and install.

- * Please do not return any products to the store. For any missing or replacement parts for electric fireplace insert, wood pieces or hardware, please contact FEBO Customer Service. Email: service@febointernational.com, Phone: 1-877-355-3326 or 1-925-820-8478 Working Hours: Monday - Friday, 9:00AM - 4:00PM (Pacific Standard Time)

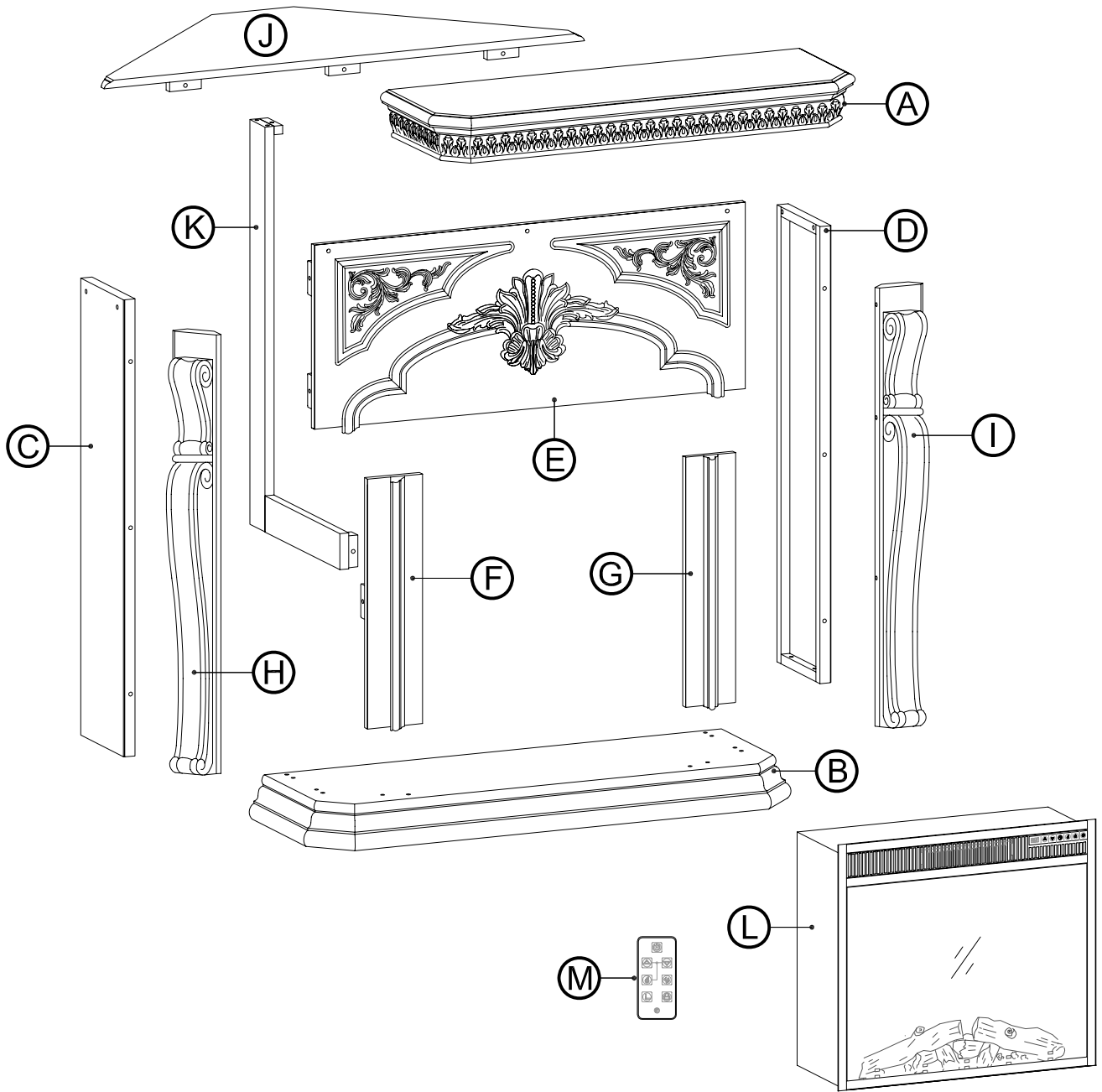







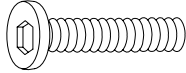

PARTS LIST

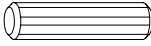
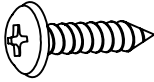
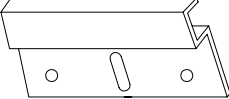
PART	DESCRIPTION	QUANTITY
A	TOP FRAME	1
B	BASE	1
C	LEFT SIDE PANEL	1
D	RIGHT SIDE PANEL	1
E	FRONT PANEL	1
F	LEFT FRONT RAIL	1

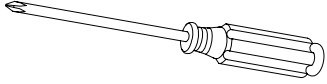
PART	DESCRIPTION	QUANTITY
G	RIGHT FRONT RAIL	1
H	LEFT POST	1
I	RIGHT POST	1
J	TRIANGLE PANEL	1
K	SUPPORT BAR	1
L	ELECTRIC FIREPLACE INSERT	1
M	REMOTE CONTROL	1

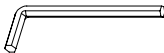
HARDWARE LIST

1	1PC	Ø1/4"	2	32PCS	Ø1/4x1-3/8"	3	32PCS	Ø1/4"x11mm
ALLEN WRENCH			ALLEN BOLT			SPRING WASHER		
								
4	32PCS	Ø1/4"x16mm	5	14PCS	Ø8x25mm	6	6PCS	8#*1/2"
FLAT WASHER			WOOD DOWEL			SCREW		
								
7	2PCS		8	1PCS		OTHER TOOL NEEDED:		
METAL BRACKET			Touch-up pen			PHILLIPS SCREWDRIVER		
						(NOT INCLUDED) 		

REQUIRED HARDWARE IN THIS STEP			
NO.	DESCRIPTION	SKETCH	QTY
1	ALLEN WRENCH		1 PC
2	ALLEN BOLT Ø1/4x1-3/8"		2 PCS
3	SPRING WASHER		2 PCS
4	FLAT WASHER		2 PCS
5	WOOD DOWEL		4 PCS

CAUTION:

2 Adults required for assembly.

Do not use power tools in assembly.

Before assembly, please check the parts list and hardware list carefully.





Please start the assembly steps on a soft flat surface to avoid scratching.

Step 1:

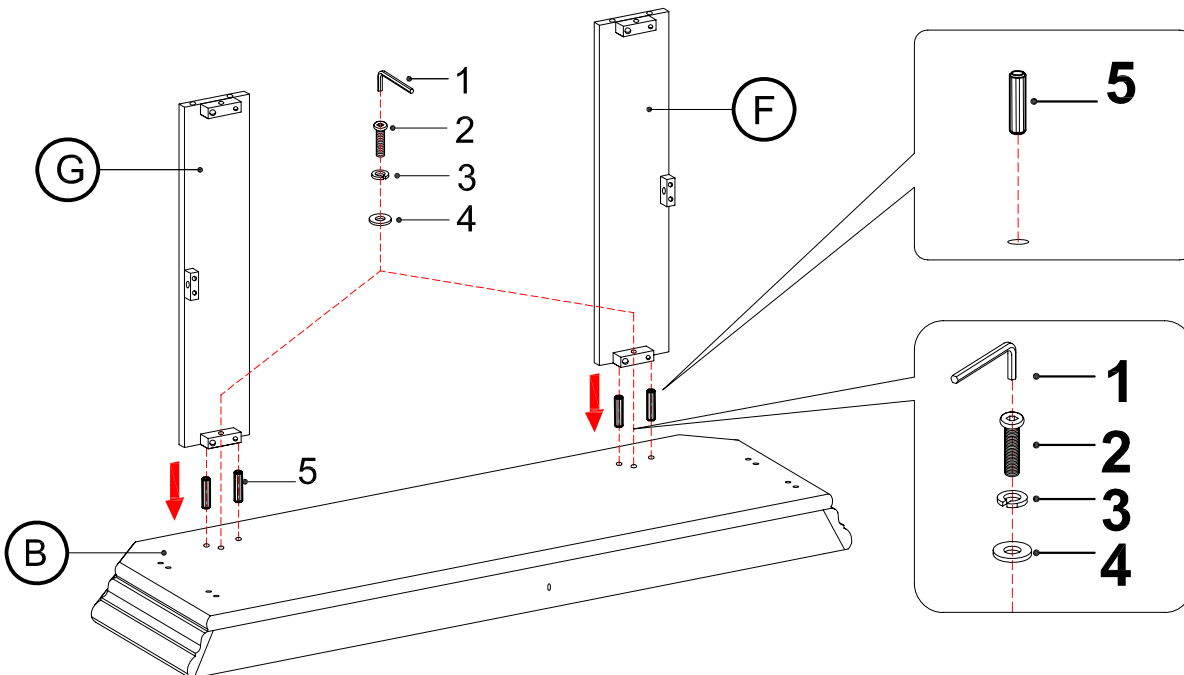
Insert 4 pcs Wood Dowel (5) into the pre-drilled holes of Base (B).

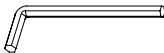
Attach the Left Front Rails (F) and Right Front Rails (G) to Base (B) by using 2 pcs Flat Washer (4), 2 pcs Spring Washer (3) and 2 pcs Allen Bolt (2). Do Not fully tighten bolts at this time





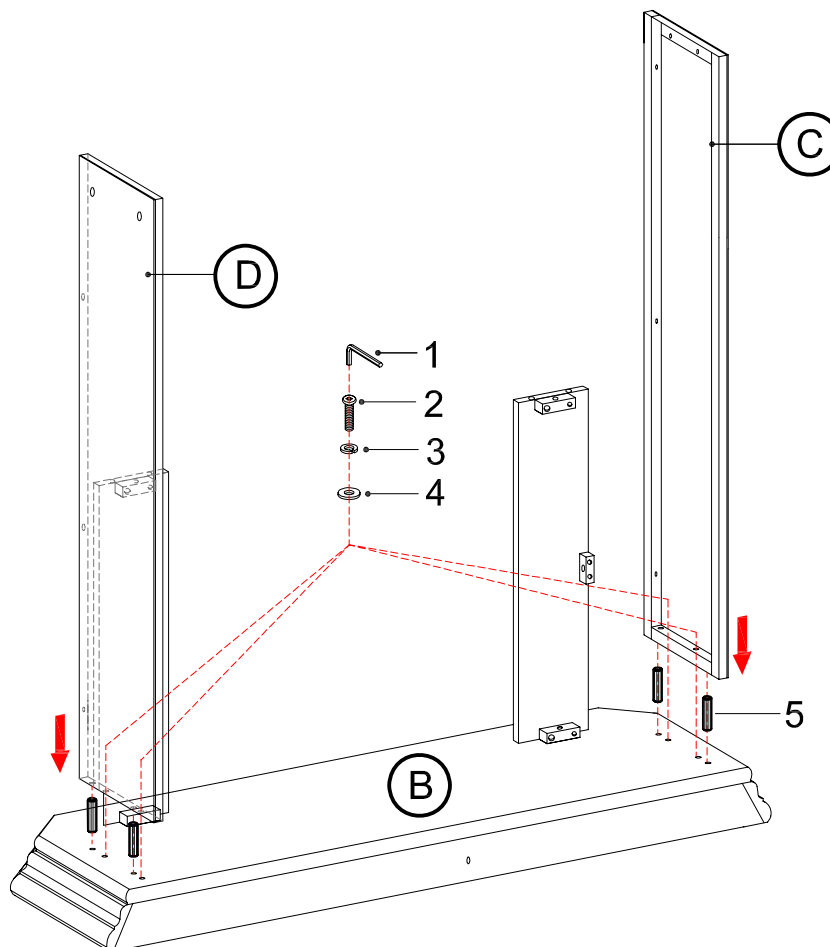

REQUIRED HARDWARE IN THIS STEP			
NO.	DESCRIPTION	SKETCH	QTY
1	ALLEN WRENCH		1 PC
2	ALLEN BOLT Ø1/4x1-3/8"		4PCS
3	SPRING WASHER		4PCS
4	FLAT WASHER		4PCS
5	WOOD DOWEL		4PCS

Step 2:

Insert 4 pcs Wood Dowel (5) into the pre-drilled holes of Base (B). Attach the Right Side Panel (C) and Left Side Panel (D) to Base (B) and using 2 pcs Flat Washer (4), 2 pcs Spring Washer (3) and 2 pcs Allen Bolt (2). Do Not fully tighten bolts at this time.





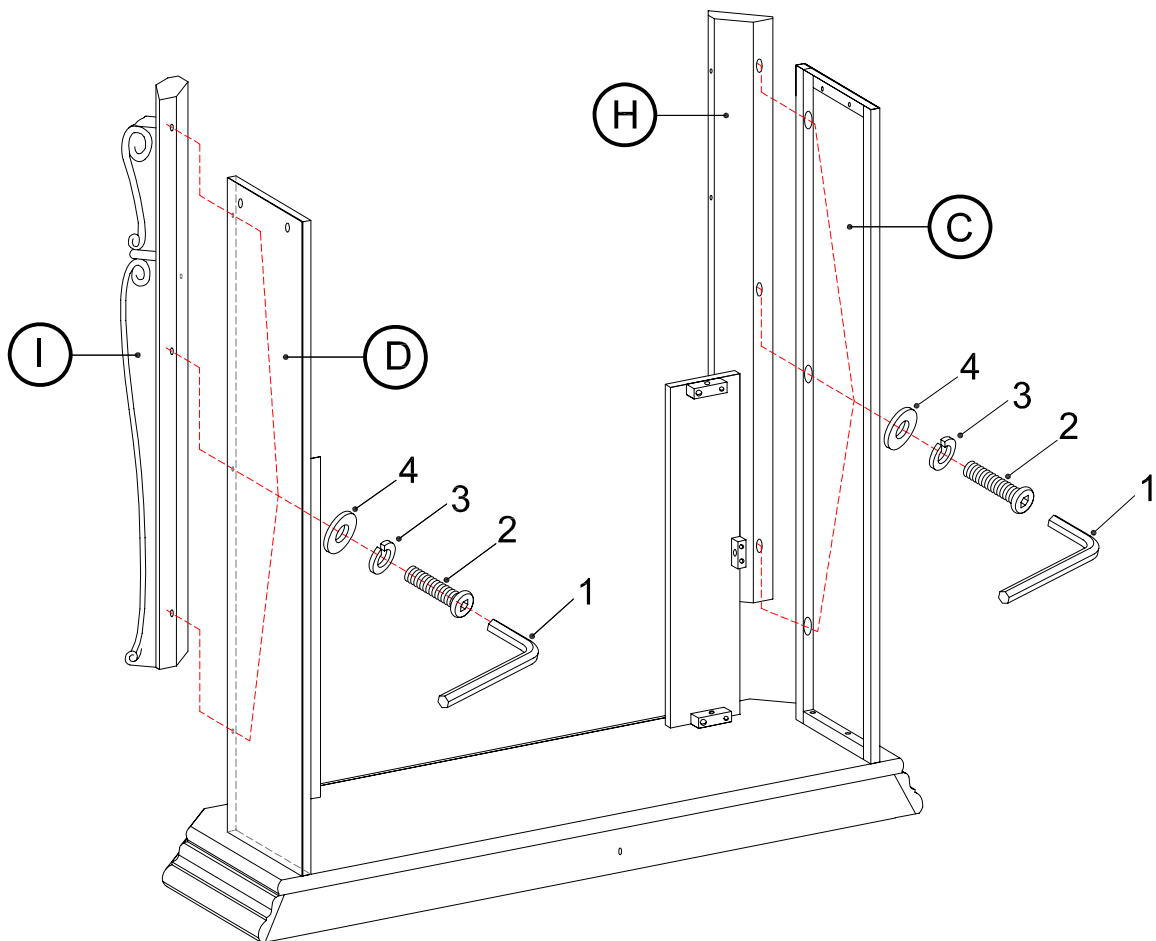

REQUIRED HARDWARE IN THIS STEP			
NO.	DESCRIPTION	SKETCH	QTY
1	ALLEN WRENCH		1PC
2	ALLEN BOLT Ø1/4x1-3/8"		6PCS
3	SPRING WASHER		6PCS
4	FLAT WASHER		6PCS

Step 3:

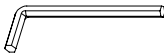
Attach the Right Post (H) and Left Post (I) to Right Side Panel (C) and Left Side Panel (D) and secure using 6 pcs Flat Washer (4), 6 pcs Spring Washer (3) and 6 pcs Allen Bolt (2). Do Not fully tighten bolts at this time.





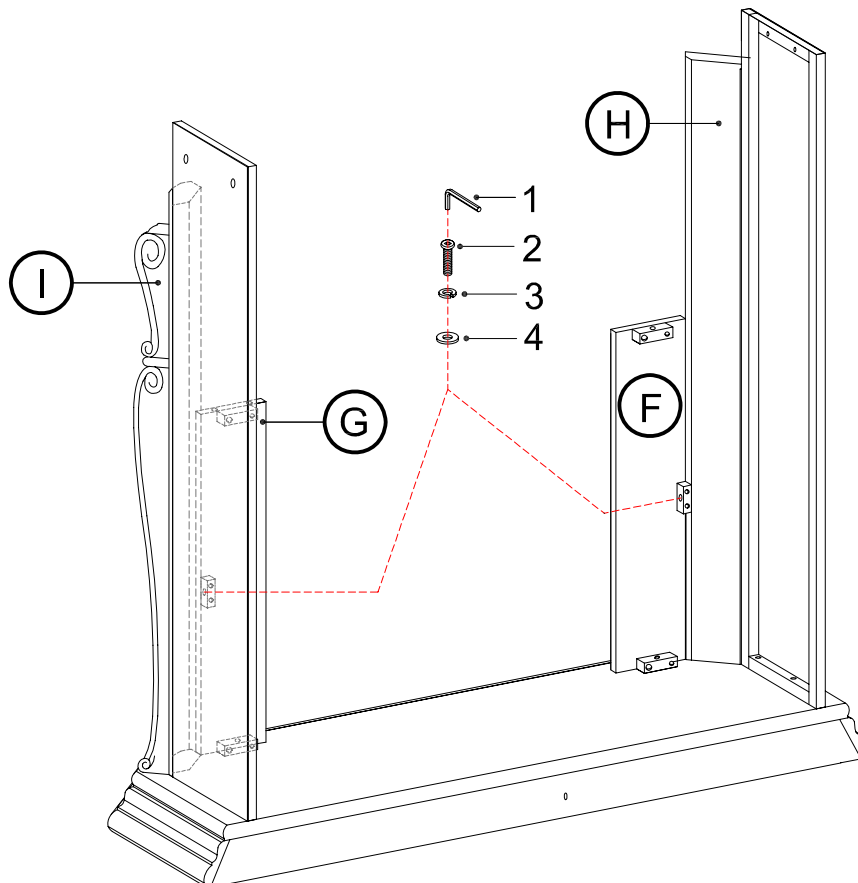

REQUIRED HARDWARE IN THIS STEP			
NO.	DESCRIPTION	SKETCH	QTY
1	ALLEN WRENCH		1PC
2	ALLEN BOLT Ø1/4x1-3/8"		2PCS
3	SPRING WASHER		2PCS
4	FLAT WASHER		2PCS

Step 4:

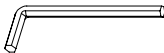
Attach the Right Post (H) and Left Post (I) to Right Front Rail (F) and Left Front Rail (G) by using 2 pcs Flat Washer (4), 2 pcs Spring Washer (3) and 2 pcs Allen Bolt (2).
Do Not fully tighten bolts at this time.







REQUIRED HARDWARE IN THIS STEP			
NO.	DESCRIPTION	SKETCH	QTY
1	ALLEN WRENCH		1PC
2	ALLEN BOLT Ø1/4x1-3/8"		6PCS
3	SPRING WASHER		6PCS
4	FLAT WASHER		6PCS
5	WOOD DOWEL		4PCS

Step 5 :

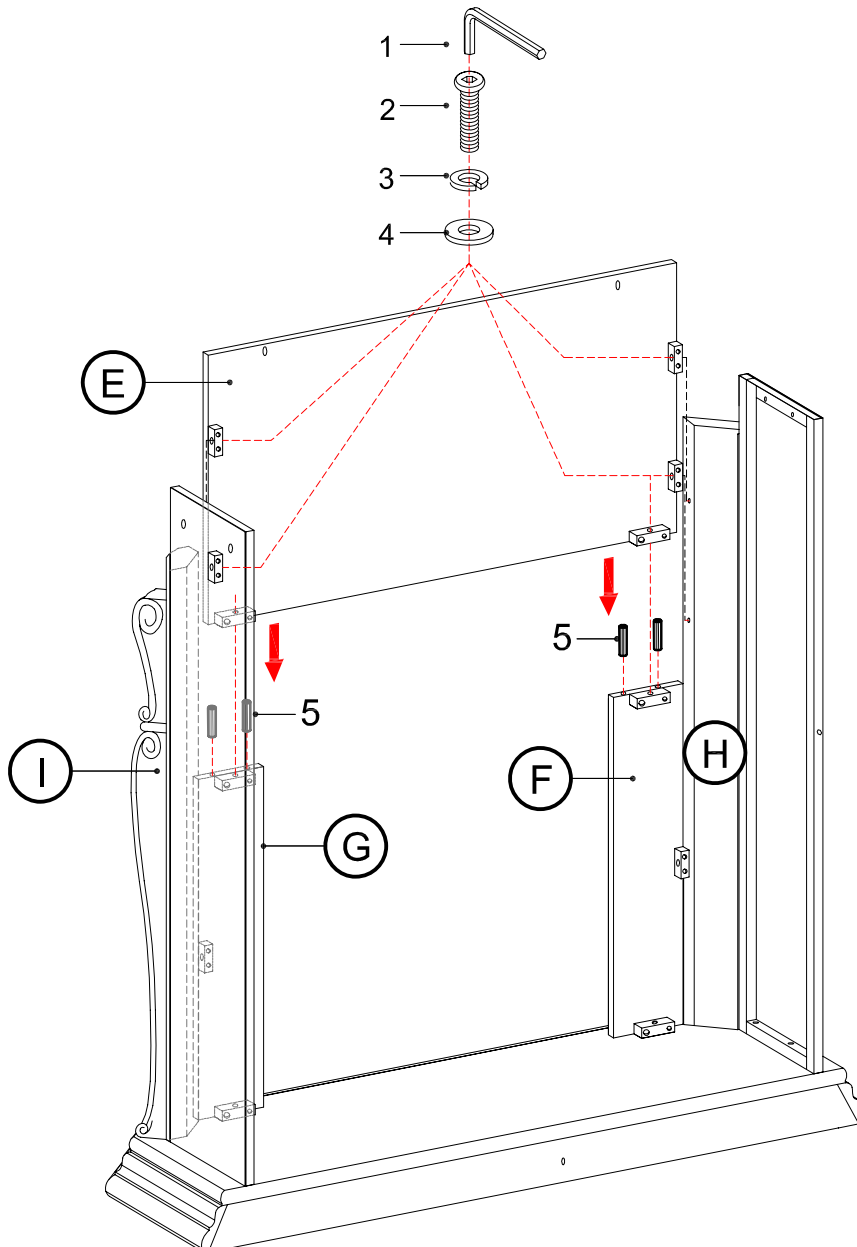
Insert 4 pcs Wood Dowel (5) to the pre-drilled holes of Right Front Rail (G) and Left Front Rail (F), Place Front Panel (E) onto Right Front Rail (G) and Left Front Rail (F) and attach to Left Post (I) and Right Post (H) and Right Front Rail (G) and Left Front Rail (F) by using 6 pcs Flat Washer (4), 6 pcs Spring Washer (3) and 6 pcs Allen Bolt (2).

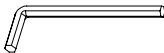
Do Not fully tighten bolts at this time.





REQUIRED HARDWARE IN THIS STEP			
NO.	DESCRIPTION	SKETCH	QTY
1	ALLEN WRENCH		1PC
2	ALLEN BOLT Ø1/4x1-3/8"		7PCS
3	SPRING WASHER		7PCS
4	FLAT WASHER		7PCS

Step 6:

Place Top Frame (A) onto Right Side Panel (C) , Left Side Panel (D) and Front Panel (E) and attach using 7 pcs Flat Washer (4), 7 pcs Spring Washer (3) and 7 pcs Allen Bolt (2). Fully tighten all bolts in this step.

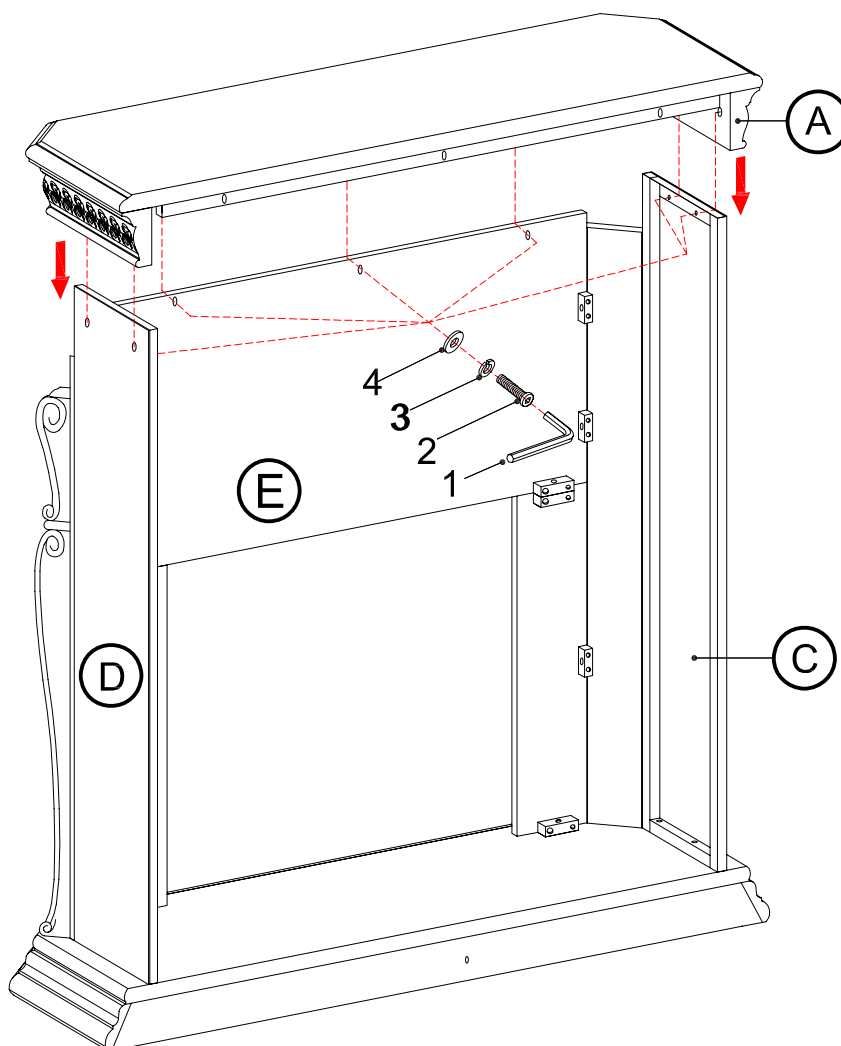
ATTENTION: Fully tighten all bolts from Steps 1 through 5 at this time.

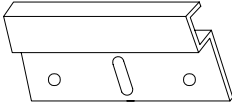
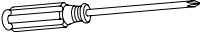

REQUIRED HARDWARE IN THIS STEP			
NO.	DESCRIPTION	SKETCH	QTY
6	SCREW		6PCS
7	METAL BRACKET		2PCS
	PHILLIPS SCREW DRIVER		NOT INCLUDED



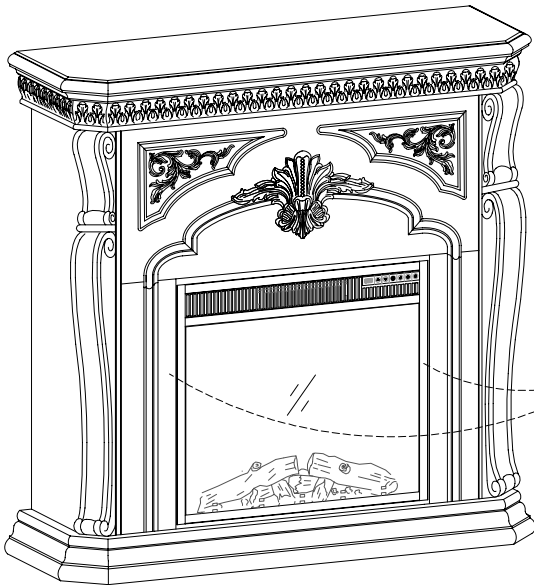

Step 7:

Place the Electric Fireplace Insert (L) inside the mantle and center in the opening. Attach the Electric Fireplace Insert (L) to the mantel using 2 pcs Metal Bracket (7) and 6 pcs Screws (6). Fully tighten all screws.

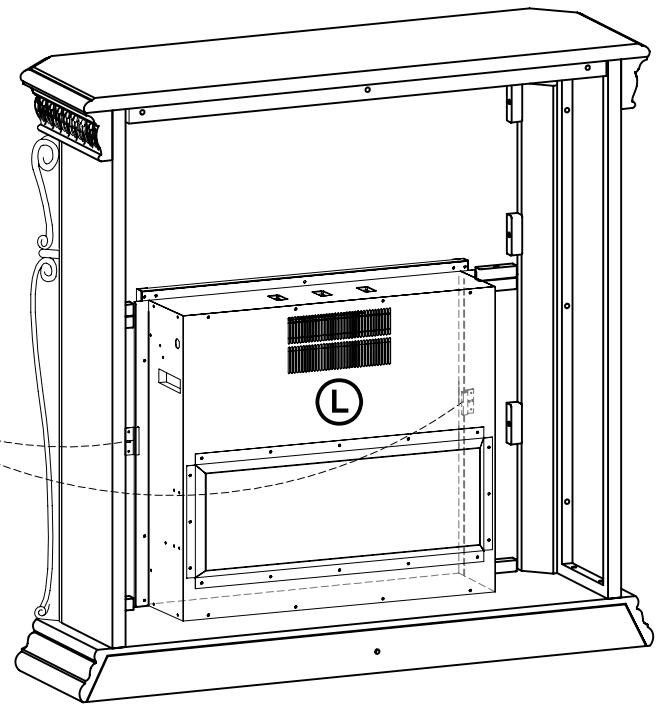
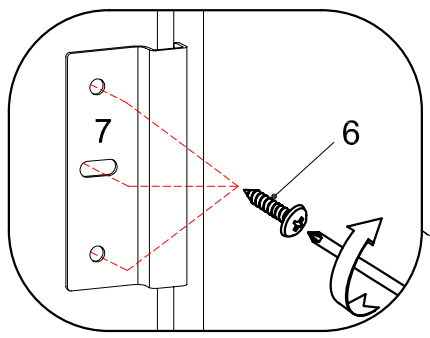

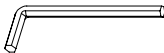
Make sure the Electric Fireplace is centered in the opening.



REQUIRED HARDWARE IN THIS STEP			
NO.	DESCRIPTION	SKETCH	QTY
1	ALLEN WRENCH		1PC
2	ALLEN BOLT Ø1/4x1-3/8"		5PCS
3	SPRING WASHER		5PCS
4	FLAT WASHER		5PCS
5	WOOD DOWEL		2PCS

Step 8 (Optional):

Attach Support Bar (K) to Base (B) using 1 pc Flat Washer (4), 1 pc Spring Washer (3) and 1 pc Allen Bolt (2). Fully tighten bolt.

Insert 2 pcs Wood Dowel (5) into top of Support Bar (K).

Align the pre-drilled holes in Triangle Panel (J) with the Wood Dowels (5) in Support Bar (K) and attach Triangle Panel (J) to Top Frame (A) using 3 pcs Flat Washer (4), 3 pcs Spring Washer (3) and 3 pcs Allen Bolt (2). Ensure the corners and top of Triangle Panel (J) are Flush with Top Frame (A) and fully tighten all bolts.

Attach Triangle Panel (J) to Support Bar (K) using 1 pc Flat Washer (4), 1 pc Spring Washer (3) and 1 pc Allen Bolt (2). Fully tighten Bolt.

Attention:

DO NOT place items weighing more than 20 lbs in total on the Triangle Panel (J). It may result in instability and cause injury.

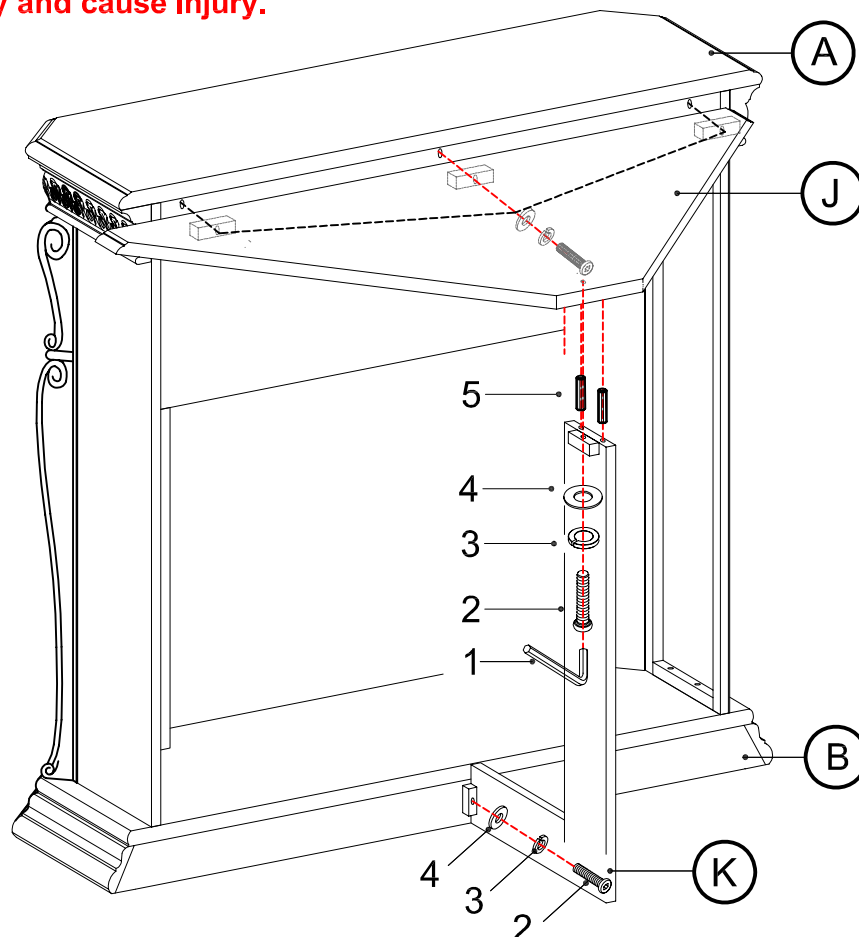

Step 9:

Assembly is complete. Your elegant Cherry Corner Fireplace is ready for use.



MADE IN CHINA