



IMPORT CORRUGATE DISPLAY STANDARDS

Effective Immediately

Vendors are required to conform to the process outlined in this guide.

**Only Color Exceptions for Displays can be found on Page 9.
Otherwise reference Big Lots Brand Guides and Art Packs.**

REQUIREMENTS FOR:

- Stackable PDQ's**
- Side Kicks**
- Floor/Pallet Displays**

TABLE OF CONTENTS

Blue section headings are clickable links

| | |
|--|----|
| BIG LOTS DISPLAY STANDARDS: GUIDELINES FOR BUYERS | 3 |
| Big Lots Corrugated Display Standards | 5 |
| Required Carton Marking Icons | 6 |
| NOTE: For questions on Carton Markings contact vendorcompliance@biglots.com | |
| General Specifications/Colors..... | 9 |
| Big Lots Stackable PDQ Standards | 10 |
| Stackable PDQ Approval Process | 12 |
| Required Transit Testing for ALL Floor/Pallet Displays | 13 |
| Stackable PDQ Visual Reference | 14 |
| Quarter Pallet Requirements | 16 |
| Stackable PDQ Master Carton Marking Icons..... | 17 |
| Big Lots Side Kick Standards | 19 |
| Side Kick Design Approval Process | 20 |
| Required Transit Testing for ALL Side Kicks..... | 22 |
| Side Kick Visual Reference | 23 |
| Heavy Duty Side Kick..... | 24 |
| General Recommendations..... | 27 |
| General Construction..... | 29 |
| Side Kick Master Cartons..... | 30 |
| Proper Loading of Side Kicks..... | 32 |
| Hooks for Hanging Product | 33 |
| Side Kick Standards | 35 |
| Side Kick Master Carton Marking Icons | 36 |
| Big Lots Floor Display Standards | 37 |
| Floor Display Design Approval Process | 38 |
| Required Transit Testing for ALL Floor/Pallet Displays | 40 |
| Floor Display Standards..... | 41 |
| Guidelines and Requirements | 42 |
| Pallet Display Options | 44 |
| Secondary Packaging..... | 48 |
| Hardware | 49 |
| Top View of Pallet Layouts | 50 |
| Floor Display Best Practices | 51 |
| Floor Display with Shroud | 53 |
| Floor Display Master Carton Marking Icons..... | 54 |
| Big Lots Required Transit Testing | 56 |

BIG LOTS DISPLAY STANDARDS: GUIDELINES FOR BUYERS

THERE ARE ONLY 2 TYPES OF DISPLAYS:

1. BRANDED (EITHER BIG LOTS PRIVATE BRAND OR ANY BRAND THAT DOES NOT REQUIRE THE USE OF THEIR PDQ or DISPLAY)

PDQs: will contain a Brand Logo and Retail only.

Displays (Side Kicks & Floor Displays): will contain Brand Logo, Item Description & Retail

2. NATIONAL BRANDS – Big Lots will accept pre-produced PDQs & Displays for highly recognized national brands that require the use of their display for display purposes. These brands must be approved by SVP, Marketing or EVP, Merchandising/Marketing. EPR's must be submitted as Transit Testing documents will need to be submitted to the Big Lots Packaging team (packaging@biglots.com) for approval prior to mass printing.

- The majority of our PDQs and Displays will fall into the first category.
- For products without a national/captive brand, the PDQ will have just the retail price (this option shouldn't occur as often as the others).
- For products without a national /captive brand, the Displays (Side Kicks & Floor Displays) will have the Item Description and retail price.
- No "Vendor Art" displays will be accepted. Buyers will need to submit EPRs (Electronic Package Request Form) for these items and indicate the appropriate PDQ art codes used. Only the item price will be listed.
- **An EPR is required for ALL Side Kicks, Stackable PDQ's and Pallet/Floor Displays (includes all Vendor Art and/or National Brands).**
- **Key exception:** If you are purchasing a close-out or an "in and out" item in commodities that is **already in a display**, you should NOT incur the additional cost of CHANGING the display to these standards. NO EPR IS NEEDED FOR THESE ITEMS NOR DOES THIS ITEM NEED TO GO THROUGH THE DISPLAY APPROVAL PROCESS

BIG LOTS DISPLAY STANDARDS: GUIDELINES FOR BUYERS

EVERYTHING YOU NEED TO KNOW ABOUT CAPTIVE AND/OR NATIONAL BRAND PDQs & DISPLAY DESIGN

- ALL Displays (Side Kicks & Floor Displays) only will utilize white type for the item description, item price point and logos. Any displays using light colors the price point and logo will be printed in black for better visibility.
- ALL PDQs only will utilize white type item price point and logos. Any PDQs using light colors the price point and logo will be printed in black for better visibility.
- o ALL Displays & PDQs require at least (2) color printing: background color + gloss varnish to provide a glossy scuff-resistant finish
- ALL information on the PDQs and the Displays is required to be printed directly on the corrugate. **Peel and stick labels are not allowed. Front facing costs about the same as color facings, therefore, you should NOT use stick-on labels.**

BIG LOTS CORRUGATED DISPLAY STANDARDS

INTRODUCTION:

This document provides our vendors with the information and resources needed to create all Shelf PDQ's, Stackable PDQ's, Side Kicks and Floor Displays. **See Big Lots Art Packs and Brand Guides for specific PDQ colors. Color Exceptions appear on page 10 of this document.**

It includes:

1. A list of required fonts, sizes, color themes and sample color layouts.
These sample layouts are not camera ready; customize the layout for each shelf PDQ, Stackable PDQ, Side Kick or Floor Display using information provided by the buyer.

NOTE: Big Lots is not permitted to copy type fonts to the disc for each format. Vendors must purchase the identified fonts or similar alternatives (to be approved by Big Lots).

2. Photo examples of what to do and what NOT to do in building the shelf PDQs, Stackable PDQ's, Side Kicks and Floor Displays.

3. **Transit Testing Standards REQUIRED** (see page 56) for all Stackable PDQ's, Side Kicks and Floor/Pallet Displays.

NOTE: Anticipate approximately 2 weeks for transit testing to be performed and completed.

4. **REQUIRED Carton Marking Icons** Vendors are responsible for making sure that the carton marking icons are correct prior to Big Lots receiving the merchandise in our DCs. Please note all carton markings are required to be reviewed and approved by vendor compliance. Carton marking icons require DCs to give special handling to each box that comes through the sorters to be loaded on our trucks for outbound delivery to our stores.

- Icon(s) may be printed directly on the box or printed labels can be placed on each box.

- Vendors are **REQUIRED** to use opaque cover-up labels on master cartons if the icons are incorrect.

NOTE: Required Carton Markings document and icons can be found on our website at: <http://www.biglots.com/corporate/vendor-relations/vendor-routing-and-compliance>

5. Follow the outlined approval processes found on pages 12, 20, and 38.

Please do not discard this guide; it may be used for future packaging.

NOTE: ALL DISPLAYS ARE EXPECTED TO SURVIVE 13 TOUCH POINTS IN SUPPLY CHAIN AND LAST 9-14 WEEKS ON STORE FLOOR.

REQUIRED CARTON MARKING ICONS

The carton marking icons shown below are **required to be placed in the bottom left corner** of the Master Shipping Carton **when applicable**. **Icons must appear on at least four different sides of the box and in Pantone 032.**



THIS SIDE UP INDICATOR

ICON: Carton is to Ship this side up.

USE: when the safety of the contents necessitates the container be stored or stacked with the top surface up, and on cartons that should never be inverted or laid on their side

EXAMPLES: picture frames, liquids, lamps, glass, white out, ceramics, mirrors and framed prints.
(Use on anything other than the examples listed above takes away the importance of the arrows).

NOTE:
 Arrows-Up takes precedence over saving space on our trucks to the stores.



NOTE: This photo is how our DC's will pack items on our trucks however, stores would not be able to place this item as shown above on conveyor for unloading our trucks.



FRAGILE-HANDLE WITH CARE

ICON: Use only if the item is Fragile

USE: this carton marking icon if item contains glass

EXAMPLES: glass, mirrors, patio tables, ceramic pots, light bulbs, porcelain



Don't use words, instead use **Red** icons as shown in this document.

REMEMBER:
 Big Lots vendors are responsible for using the appropriate carton marking icon(s) to prevent damage prior to items arriving in our DC's and/or stores.

Big Lots reserves the right to charge back vendors if wrong carton marking icons are used.

Can use more than one icon if necessary.
 Example: glassware (Arrow Up / Fragile etc.)

REQUIRED CARTON MARKING ICONS CONT'D



ICON: PDQ - Do Not Stack Heavy Product On Top Of Carton

USE: Communicates PDQ display to the DC associate. DC associate will then avoid stacking other heavy boxes onto the PDQ display/product when loading our trucks to avoid damaging the PDQ.

**PDQ - DO NOT STACK HEAVY
PRODUCT ON TOP OF CARTON**



ICON: SIDE KICK - Do Not Stack Heavy Product On Top Of Carton

USE: Communicates SIDE KICK display to the DC associate. DC associate will then avoid stacking other heavy boxes onto the SIDE KICK display/product when loading our trucks to avoid damaging the SIDEKICK.

**SIDE KICK - DO NOT STACK HEAVY
PRODUCT ON TOP OF CARTON**



ICON: FLOOR DISPLAY - Do Not Stack Heavy Product On Top Of Carton

USE: Communicates FLOOR DISPLAY to the DC associate. DC associate will then avoid stacking other heavy boxes onto the FLOOR DISPLAY/product when loading our trucks to avoid damaging the FLOOR DISPLAY.

**FLOOR DISPLAY - DO NOT STACK
HEAVY PRODUCT ON TOP OF CARTON**

Can use more than one icon if necessary.

Example: glassware (Arrow Up / Fragile etc.)

REQUIRED CARTON MARKING ICONS CONT'D



ICON: Team Lifting

USE: If box weighs more than 70 lbs (31.75 kg), this carton marking icon must be used.

EXAMPLES: Furniture, Hardware and Lawn and Garden (Items listed are not inclusive)

NOTE:

This icon will also communicate to our DC associates to place this item on the bottom of trucks to prevent crushing of other cartons.

HEAVY

ICON: Team Lifting

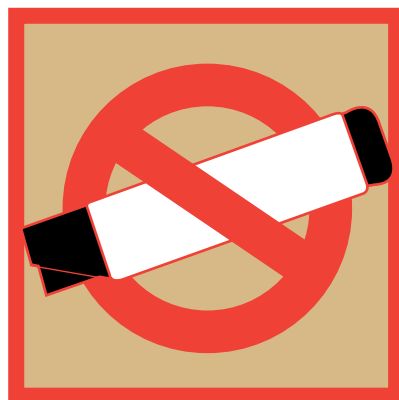

ICON: No Blades

USE: Do not use sharp object when opening box.

EXAMPLES: cushions, pillows, wicker furniture, bedding, cloth coolers, rugs, towels, tablecloths, stuffed animals (Items listed are not inclusive)

NOTE: Logo should appear on top and bottom of box. Logo communicates to the stores that the merchandise inside can easily be cut and damaged when using a knife to open the box.

DO NOT USE SHARP OBJECT WHEN OPENING BOX.

Can use more than one icon if necessary.

Example: glassware (Arrow Up / Fragile etc.)

Carton Marking Icon Sizing Chart

Carton Marking Icons

Please reference PLM for determining the appropriate size carton marking icon(s) to use based on carton cube. See chart above.

Please note all carton markings are required to be reviewed and approved by vendor compliance.

| CARTON CUBE FROM IPDS SHEETS | ICON SIZES (MINIMUM SIZES) |
|------------------------------|----------------------------|
| up to 2 cubes | 1" X 1" |
| 3 - 5 cubes | 2" X 2" |
| 6 - 10 cubes | 3" X 3" |
| cube 11 and up | 4" X 4" |

- Required Carton Markings Document and icons can be found on our website at:

<http://www.biglots.com/corporate/vendor-relations/vendor-routing-and-compliance>

NOTE: For questions on Carton Markings contact vendorcompliance@biglots.com

BIG LOTS CORRUGATE DISPLAY STANDARDS

GENERAL SPECIFICATIONS - ALL PDQ's, Stackable PDQ's, Side Kicks & Floor Displays

ALL PDQ's (including National Brand) will be **flood coated on three sides (front and both side panels)**

ALL Stackable PDQ's and Floor Displays will be **flood coated on four sides (front, back and both side panels)**

ALL Side Kicks will be **flood coated on top, bottom, both side panels and inside of side kick back panel**

FOR PDQ's

ALL PDQ's (other than National Brand) will utilize white type for the item price point and logo. Any PDQ's using a light color the item price point and logo will be printed in black for better visibility.

- These PDQ's require at least 2 color printing : background color + **gloss varnish to provide a glossy scuff - resistant finish**
- ALL information on the PDQ's plus logo and price, should be **printed on the corrugate.**
- Peel and Stick labels are not acceptable.
- **ALL PDQ's must meet the minimum corrugate standard of B-Flute, 200# burst strength**

FOR DISPLAY's (Side Kicks & Floor Displays)

ALL displays (other than National Brand) will utilize white type for the item description and item price point, as well as white logos, Any Displays (Side Kicks & Floor Displays) using a light color the item description, item price point and logo will be printed in black for better visibility.

- These displays require at least 2 color printing : background color + **gloss varnish to provide a glossy scuff - resistant finish**
- ALL information on the displays plus item description and price, should be **printed on the corrugate.**
- Peel and Stick labels are not acceptable.
- **ALL displays must meet the minimum corrugate standard of B-Flute, 200# burst strength**

COLORS EXCEPTIONS :

Color Exceptions for PDQ & Display colors see required colors below.

See Big Lots Art Packs and Brand Guides for additional specific PDQ colors.

- For Jewelry use Pantone 877 (Metallic Silver)



**ARTCODE:
PDQSILVER**

- For NVO Big Lots (BL) Private Brand items, match color of PDQ to brand (see brands listed below)

Fresh Finds
Broyhill
Real Living
Sound Body

Climate Keeper
Big Lots
Winter Wonder Lane

- For Electronics & Electronic Accessories and Non-Branded Mirror & Wall Art Displays use Pantone Black



**ARTCODE:
PDQELECBLK**

or

**ARTCODE:
PDQMIRWALLBLK**

- For NVO (Not BL Private Brand) and Everyday items only.



**ARTCODE:
PDQCOOLGRAY10**

- For Back to School items use Pantone 647 (Blue)

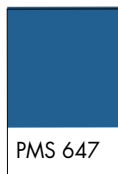

**ARTCODE:
PDQBTSBlue**

- For Holiday items not BL Private Brand



**ARTCODE:
PDQ7636**



———— **STACKABLE PDQ STANDARDS** ————

BIG LOTS STACKABLE PDQ STANDARDS continued

FONTS/SIZES:

Futura Heavy - Used for the Item Description

ABCDEFGHIJKLMNOPQRSTUVWXYZ

abcdefghijklmnopqrstuvwxyz

- Use Futura Heavy for upper and lower case (all white lettering)
- 68 pt. for 24" (60.96 cm) with one line descriptor (Item Description size can vary based on size.)
- If the item description will not fit at 68 pt., you may reduce it to no smaller than 55 pt. and stack it

Futura Bold - Used for the Retail Price

0123456789 \$

- For Retail Price Futura Bold all upper case (all white) 100 pt. type
- For Dollar Sign Futura Bold all upper case (all white) 55 pt. type, aligned with the top of the retail price.
- There should be a 1" (2.54 cm) space between the last number of the price and the right edge of the color Stackable PDQ

Note: If the retail price is a whole number, use ONLY the dollar sign and amount

\$5 right

\$5.00 wrong

- If retail is under \$1, use ONLY the decimal point and amount in Futura Bold 100 pt. type (all white)
.99 right
.99¢ wrong
- Do NOT use the decimal point if the retail price is not a whole number. Cents in Futura Bold 55 pt. type (all white), aligned with the top of the retail price
\$1⁵⁰ right
\$1.50 wrong

BIG LOTS STACKABLE PDQ STANDARDS

FLOOR/PALLET DISPLAY DESIGN APPROVAL PROCESS: Every Floor Display must go through each step in this process. Big Lots reserves the right to charge back any vendor that produces incorrect or inferior Floor Displays that have not completed this process.

1. A white pack out sample is required to be submitted for review and approval by the Columbus Packaging Team for all Domestic Orders. At this step in the process, Big Lots reserves the right to request any design changes. Recommended design changes will be sent to the vendor via email. Additional information that needs to be included with the white packout sample is Article# and Case Pack. **Be sure to allow time in this step for corrections as needed.**

If the white pack out sample is approved, go to step 2. If the sample is not approved, you will need to make revisions as necessary and re-submit a new folded sample.

NOTE: A sample is not required for close-out items.

2. Once the revised white pack out sample is approved, send the electronic artwork layout on the Side Kick dieline artwork layout should be provided to **packaging@biglots.com**

3. Once the electronic artwork layout has been approved, a color print/press proof is required. This proof must show the exact colors to be printed in mass production and be on the same corrugate (color and weight) to be used in mass production. An ink draw down swatch with Varnish on the actual corrugate is also acceptable, at this stage. If you require a signed print proof to be sent back to you, please send two.

If the proof is approved, go to step 4. If the proof is not approved, you will need to make revisions as necessary and re-submit a new proof. Be sure to allow time in this step if corrections are needed.

White pack out samples & print proofs should be sent to:

Big Lots Corporate Office
ATTN: PACKAGING DEPT
4860 E. Dublin Granville Road
Columbus, Ohio 43081

4. Stackable PDQs will require testing prior to mass production.
See page 56 for transit testing requirements.

5. Begin mass printing after Transit test has passed. Vendors are required to send one final printed Floor Display (please ship this sample flat packed for our files) sample to Big Lots or Big Lots Agent. Send it to the same address as in step 3 above. **If a buyer requires a sample, an additional sample should be sent separately to their attention.**

If you have any questions you may email us at packaging@biglots.com.

NOTE: FLOOR/PALLET DISPLAYS ARE EXPECTED TO SURVIVE 13 TOUCH POINTS IN OUR SUPPLY CHAIN AND LAST 9-14 WEEKS ON STORE FLOOR.

REQUIRED TRANSIT TESTING FOR **ALL** FLOOR/PALLET DISPLAYS ONLY

The purpose of the ISTA testing is to make sure merchandise flows through the supply chain and out into the retail stores without damage. Our goal is to reduce complaints, increase product sales and not have to re-merchandise (store labor).

All Floor/Pallet displays (includes Stackable PDQ), now require ISTA 3E transit testing.

For Import Vendors Assigned to an Agent - You will be required to have the Side Kicks and Floor/Pallet Displays tested with their designated testing facility prior to mass printing/production.

For National Branded Vendors (Imported Purchases) - You will be required to have the Side Kicks and Floor/Pallet Displays tested with Bureau Veritas prior to mass printing/production. Send all passed Transit Test reports to packaging@biglots.com for our review prior to proceeding to mass production.

For Domestic Importers with FOB U.S.A - You will be required to have the Side Kicks and Floor/Pallet Displays tested with an ISTA (International Safe Transit Association) Certified Lab prior to mass printing/production. Please refer to www.ista.org to locate a certified lab in your area. If a vendor chooses one of the following testing facilities: Submit all **“passed”** test reports to packaging@biglots.com for approval prior to mass printing/production.

For Items Purchased Domestically (Including National Branded Vendors) - You will be required to have the Side Kicks and Floor/Pallet Displays tested with an ISTA Certified Lab prior to mass printing/production. Please refer to www.ista.org to locate a certified lab in your area. Submit all **“passed”** test reports to packaging@biglots.com for approval prior to mass printing/production.

NOTE: Allow 2 weeks for testing and another week to obtain final test report.



STACKABLE PDQ VISUAL REFERENCE

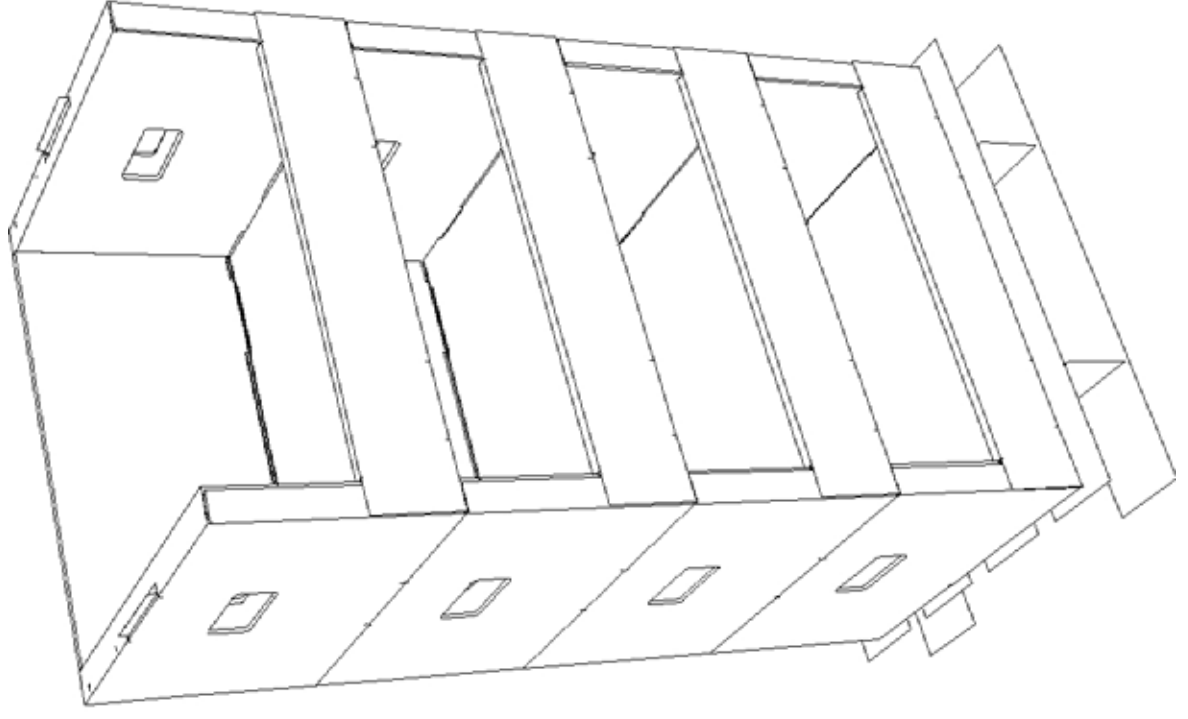

Dimensions:

Maximum Weight: 20 lbs. per PDQ (tier)

Maximum Outer Dimension (OD): 10.25" H x 23.125" W x 17" D
(26.035 cm x 58.7375 cm x 43.18 cm)

Maximum Inner Dimension (ID): 10" H x 19.15" W x 15.12" D
(25.4 cm x 48.641cm x 38.4048 cm)

Maximum Overall Height for Domestic Orders:
52" H (132.08 cm) (Includes 5" (12.7cm) pallet)

Maximum Overall Height for Import Orders (Based on standard 40" Sea Container):
46" H (116.84 cm) (Maximum Height including 5" (12.7cm) pallet)

If buyer specifies pallet, use: 4 Way Pallet GMA B
Our standard size full pallet is 48" x 40" (121.92 cm x 101.6 cm)
Our standard size half pallet is 48" x 20" (121.92 cm x 50.8 cm)
Our standard size quarter pallet is 24" x 20" (60.96 cm x 50.8 cm)

Maximum Weight Limit of Display is 80 lbs. (does not include pallet)

STACKABLE PDQ STANDARDS

Minimum Material Specifications:

- 51 ECT (Edge Crush TEST*) OR 350# (Mullen Test**) Bleached white outside liner EB-flute + Scuff-Resistant Varnish and/or UV coating.

- **Minimum Liner Combination:**
205 gsm (42#) liner x 125 gsm (26#) medium x 175 gsm (35#) liner x 125 gsm (26#) liner x 205 gsm (42#) liner

Transit Testing:

- See page 56 for Big Lots Transit Testing Standards.

Hook and Loop Specifications:

- Side 1 features tiny hooks; Side 2 features even smaller and “hairier” loops. When the two components are pressed together, the hooks catch in the loops and the two pieces fasten. The opposing surfaces need to be fastened prior to applying to top, 1.5” sides of Stackable PDQ.
- When two or more stackable PDQ’s are placed on top of each other, a minimum of 1” (W) x 4” (L) (2.54 cm x 10.16 cm) hook and loop strip must be applied to the top of each end to securely hold multiple PDQ’s together in store and in transit.
- If one stackable PDQ tray is used to sit on a shelf, this tray would not require hook and loop strips.

Suggested Testing Protocol for Stackable PDQ’s:

ISTA (International Safe Transit Association) Test 3E

- For more information on ISTA:
International Safe Transit Association
1400 Abbott Road, Suite 160
East Lansing, Michigan 4823-1900
USA
Phone: 1-517-333-3437
Fax: 1-517-333-3813
ista@ista.org

* **Edge Crush Test (ECT)** - The Edge Crush Test is a standard industry measure of the stacking strength or corrugated board.

** **Mullen Test** - The Mullen Test is a standard measure of the bursting strength of corrugated board.

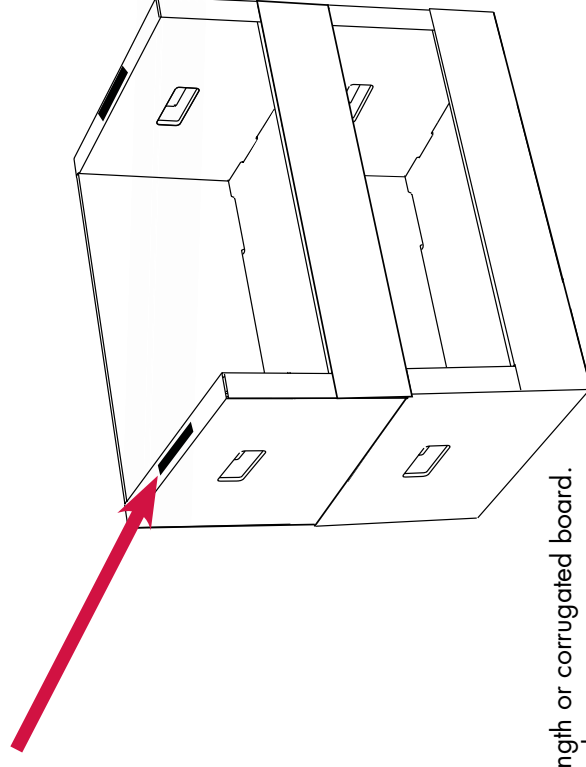

QUARTER PALLET REQUIREMENTS

1. Structure requirements:

- a. Pallets to be constructed as double wing style pallet. This pallet structure will allow for accessibility with current material handling equipment throughout the Big Lots supply chain and at the retail store level.
- b. Failure to conform to this pallet style structure may result in damage to your display due to improper handling methods.

2. Size:

- a. Ideal size for quarter pallet displays = 24 x 20" (610 x 508mm)
- b. Maximum width = 20" (508mm)
- c. Maximum Length = 24" (610mm)

3. Terminology

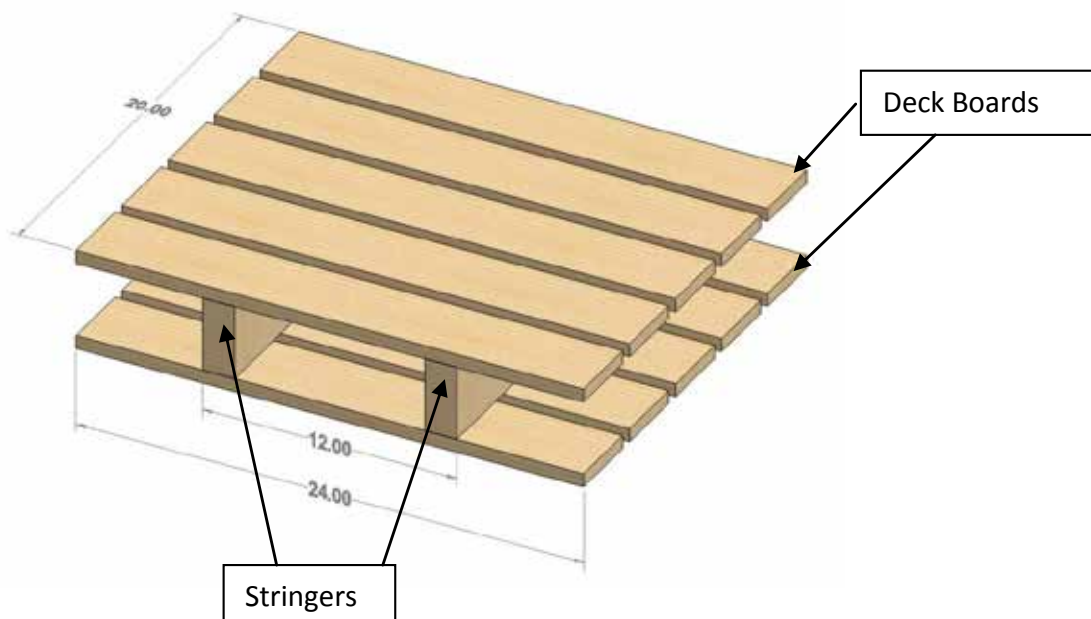

4. Construction:

- a. Pallet must consist of top and bottom deck boards to provide adequate stability
- b. Minimum pallet height = 4.5" (114mm)
- c. Stringers must be a minimum of 1.5" (37.5mm) thick and 3.5" (89mm) high
- d. Maximum stringer spacing to outside of stringers = 12" (305mm)

5. Handling



STACKABLE PDQ's

Master Carton Marking Icons

This icon communicates Floor Display to the DC associate. DC associate will then avoid stacking other heavy boxes onto the Floor Display/product when loading our trucks to avoid damaging the Floor Display.

**FLOOR
DISPLAY**

**FLOOR DISPLAY - DO NOT STACK HEAVY
PRODUCT ON TOP OF CARTON**

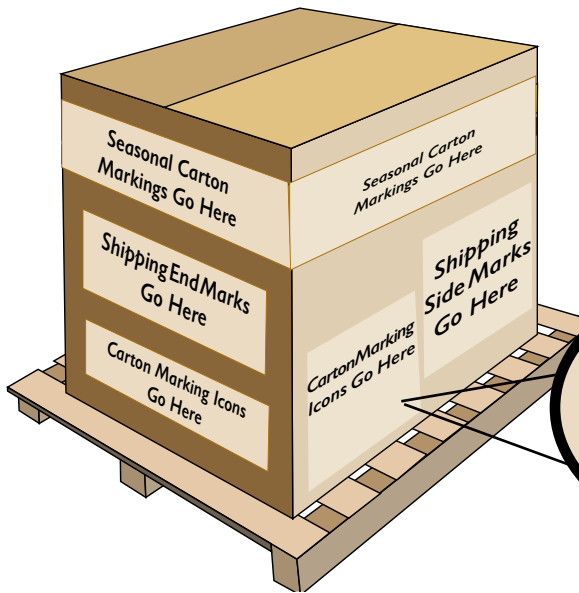

Example Only

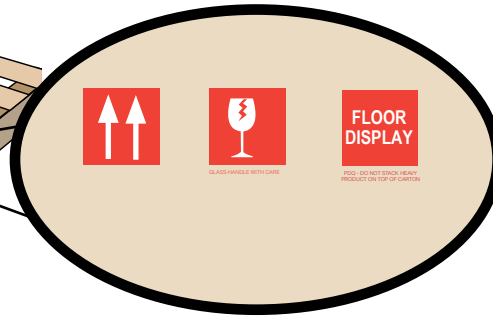

NOTE: Displays with cardboard feet are NOT ALLOWED.



NOTE: Cartons containing Floor Displays, but do not display required icon(s) are likely to be crushed during shipping.

NOTE: Carton marking icons are required to be placed on at least four different sides of the Master Shipping Carton. If the master shipping carton contains a casepack of one then the carton marking icons are also required on at least four different sides of the box. See [Carton Marking Icon Sizing Chart](#) (page 9) for appropriate size carton marking icon(s).

- Required Carton Markings Document can be found on our website at:

<http://www.biglots.com/corporate/vendor-relations/vendor-routing-and-compliance>

The above Carton Markings Icons can also be found on above website

NOTE: For questions on Carton Markings contact vendorcompliance@biglots.com

Please include a copy of this sheet and list the following information when submitting a White pack out sample for approval:

Inside Dimension (ID) of PDQ (in inches):

Height:
Width:
Depth:

Outside Dimension (OD) of PDQ (in inches):

Height:
Width:
Depth:

Overall weight of Stackable Display



SIDE KICK STANDARDS

**(Power Wing)
(Side Panel)**

BIG LOTS SIDE KICK STANDARDS

SIDE KICK DESIGN APPROVAL PROCESS: Every Side Kick must go through each step in this process. Big Lots reserves the right to charge back any vendor that produces incorrect or inferior Side Kicks that have not completed this process.

1. A **white pack out sample** is required to be submitted for review and approval by the Columbus Packaging Team. At this step in the process, Big Lots and Big Lots Agents reserve the right to request any design changes. Recommended design changes will be sent to the vendor via email. Be sure to allow time in this step for corrections as needed. Additional information that needs to be included with the white packout sample is Article# and Case Pack.

NOTE: A sample is not required for close-out items.

If the white pack out sample is approved, go to step 2. If the sample is not approved, you will need to make revisions as necessary and re-submit a new folded sample.

2. Once the revised white pack out sample is approved, send the electronic artwork layout on the Side Kick dieline artwork layout should be provided to **packaging@biglots.com**

3. Once the electronic artwork layout has been approved, a color print/press proof is required. This proof must show the exact colors to be printed in mass production and be on the same corrugate (color and weight) to be used in mass production. An ink draw down swatch with varnish on the actual corrugate is also acceptable, at this stage. If you require a signed print proof to be sent back to you, please send two.

If the proof is approved, go to step 4. If the proof is not approved, you will need to make revisions as necessary and re-submit a new proof. Be sure to allow time in this step if corrections are needed.

White pack out samples & print proofs should be sent to: **Big Lots Corporate Office
ATTN: PACKAGING DEPT
4860 E. Dublin Granville Road
Columbus, Ohio 43081**

4. Side Kicks will require testing prior to mass production. See page 105 for transit testing requirements.

5. Begin mass printing after Transit Test has passed. Vendors are required to send one final printed Side Kick (please ship this sample flat packed for our files) sample to Big Lots. Send it to the same address as in step 3 above. **If a buyer requires a sample, an additional sample should be sent separately to their attention.** If a final printed Side Kick does not match the sample submitted in the print proof, Big Lots reserves the right to charge back the vendor. **If you have any questions you may email us at packaging@biglots.com.**

NOTE: SIDE KICKS ARE EXPECTED TO SURVIVE 13 TOUCH POINTS IN SUPPLY CHAIN AND LAST 9-14 WEEKS ON STORE FLOOR.

BIG LOTS SIDE KICK STANDARDS continued

FONTS/SIZES:

Futura Heavy - Used for the Item Description

ABCDEFGHIJKLMNOPQRSTUVWXYZ

abcdefghijklmnopqrstuvwxyz

- Use Futura Heavy for upper and lower case (all white lettering)
- 68 pt. for 24" (60.96 cm) with one line descriptor (Item Description size can vary based on size.)
- If the item description will not fit at 68 pt., you may reduce it to no smaller than 55 pt. and stack it

Futura Bold - Used for the Retail Price

0123456789 \$

- For Retail Price Futura Bold all upper case (all white) 100 pt. type
- For Dollar Sign Futura Bold all upper case (all white) 55 pt. type, aligned with the top of the retail price.
- There should be a 1" (2.54 cm) space between the last number of the price and the right edge of the color Stackable PDQ

Note: If the retail price is a whole number, use ONLY the dollar sign and amount

\$5 right

\$5.00 wrong

- If retail is under \$1, use ONLY the decimal point and amount in Futura Bold 100 pt. type (all white)
.99 right
.99¢ wrong
- Do NOT use the decimal point if the retail price is not a whole number. Cents in Futura Bold 55 pt. type (all white), aligned with the top of the retail price
\$¹⁰⁰ right
\$1.50 wrong

REQUIRED TRANSIT TESTING FOR **ALL** SIDE KICKS DISPLAYS ONLY

The purpose of the ISTA testing is to make sure merchandise flows through the supply chain and out into the retail stores without damage. Our goal is to reduce complaints, increase product sales and not have to re-merchandise 1500 stores (store labor).

All Side Kick displays, now require ISTA 2A transit testing.

For Import Vendors Assigned to an Agent - You will be required to have the Side Kicks and Floor/Pallet Displays tested with their designated testing facility prior to mass printing/production.

For National Branded Vendors (Imported Purchases) - You will be required to have the Side Kicks and Floor/Pallet Displays tested with Bureau Veritas prior to mass printing/production. Send all passed Transit Test reports to packaging@biglots.com for our review prior to proceeding to mass production.

For Domestic Importers with FOB U.S.A - You will be required to have the Side Kicks and Floor/Pallet Displays tested with an ISTA (International Safe Transit Association) Certified Lab prior to mass printing/production. Please refer to www.ista.org to locate a certified lab in your area. If a vendor chooses one of the following testing facilities: BV, Intertek or SGS notify deannataylor@biglots.com. Submit all **“passed”** test reports to packaging@biglots.com for approval prior to mass printing/production.

For Items Purchased Domestically (Including National Branded Vendors) - You will be required to have the Side Kicks and Floor/Pallet Displays tested with an ISTA Certified Lab prior to mass printing/production. Please refer to www.ista.org to locate a certified lab in your area. Submit all **“passed”** test reports to packaging@biglots.com for approval prior to mass printing/production.

NOTE: Allow 2 weeks for testing and another week to obtain final test report.

Double Stack Shelf Side Kick

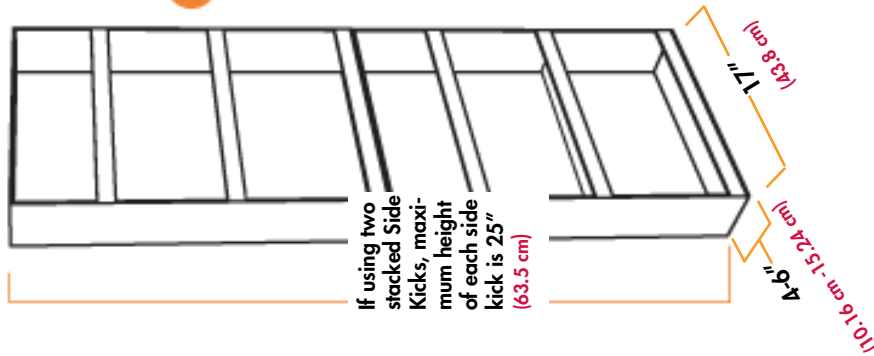

If using two stacked Side Kicks, maximum height of each side kick is 25" (63.5 cm)

Side Kick VISUAL REFERENCE

(4) die-cut slots at 1-1/4" W (3.175 cm) are needed in the back for the Power Wing Clips. This will allow sidepanel to properly hang when fully loaded. Additional die-cut slots allow store associate to change how the Side Kick hangs. Using the lower slots prevents the display from swinging backwards.

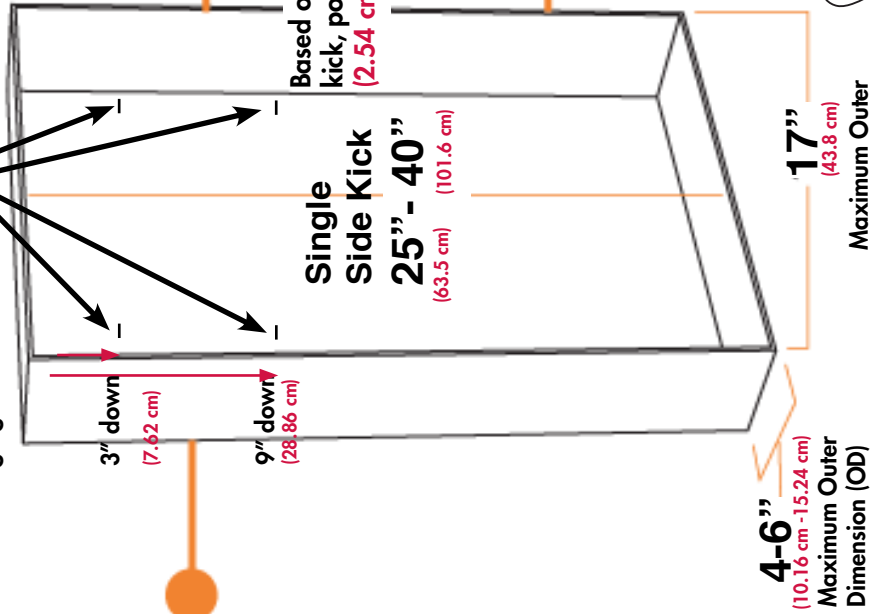

Based on a 17" (43.18 cm) wide side kick, power wing clips must start 1" (2.54 cm) from each side of sidekick.

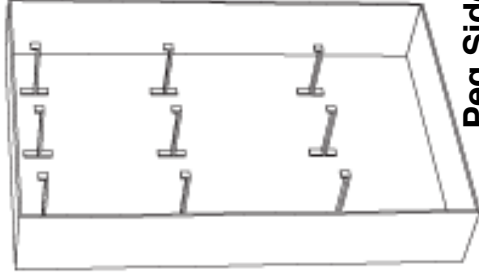

Peg Side Kick

Vendor to provide and include proper hooks (see page 75) with display.



Partitioned Side Kick

One piece divider interlocked in sidepanel display keeps corrugate dividers from collapsing and holds product in place.

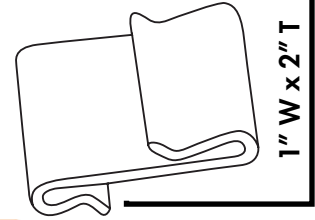

1" W x 2" T

(2.54 cm x 5.08 cm)

Power Wing Clip

- Holds corrugated display on our Wire Rack
- Holds 1/8" (0.3175 cm) B-Flute corrugate
- Each sidepanel must have a minimum of 2 clips (Heavier panels should utilize 4 or more clips)

All four sides of the Side Kick is now required to have Rollover Reinforced Sides.

Heavy Duty Shelf Side Kick w/Reinforced Front & Side Panels

For heavier or bulky items (16 lbs. or greater but still less than 20 lbs.), we recommend this PDQ.

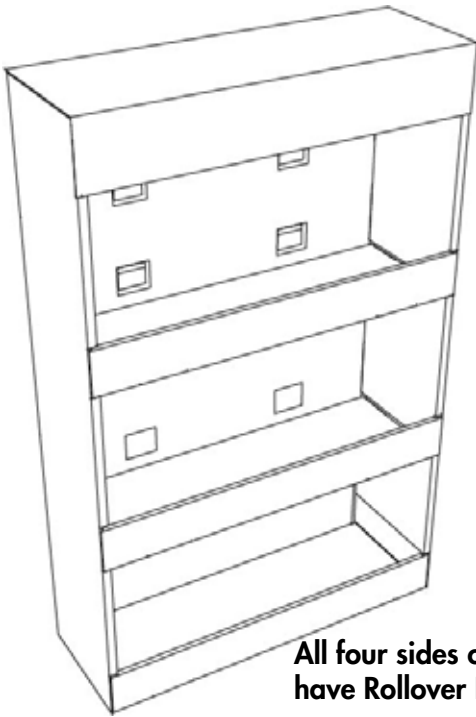

All four sides of the Side Kick are required to have Rollover Reinforced Sides.

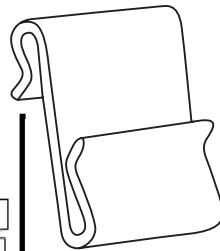
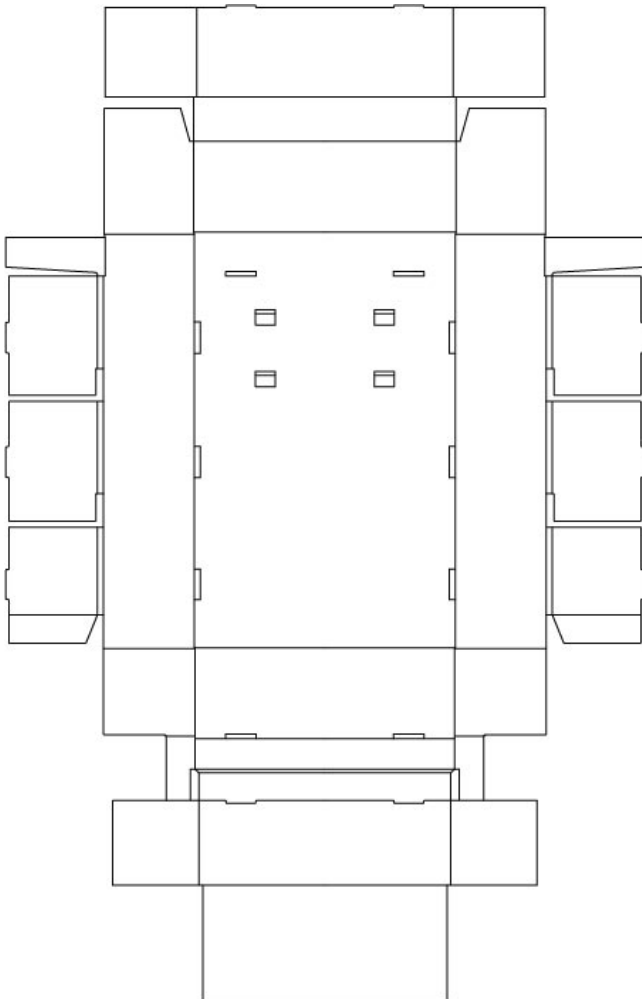
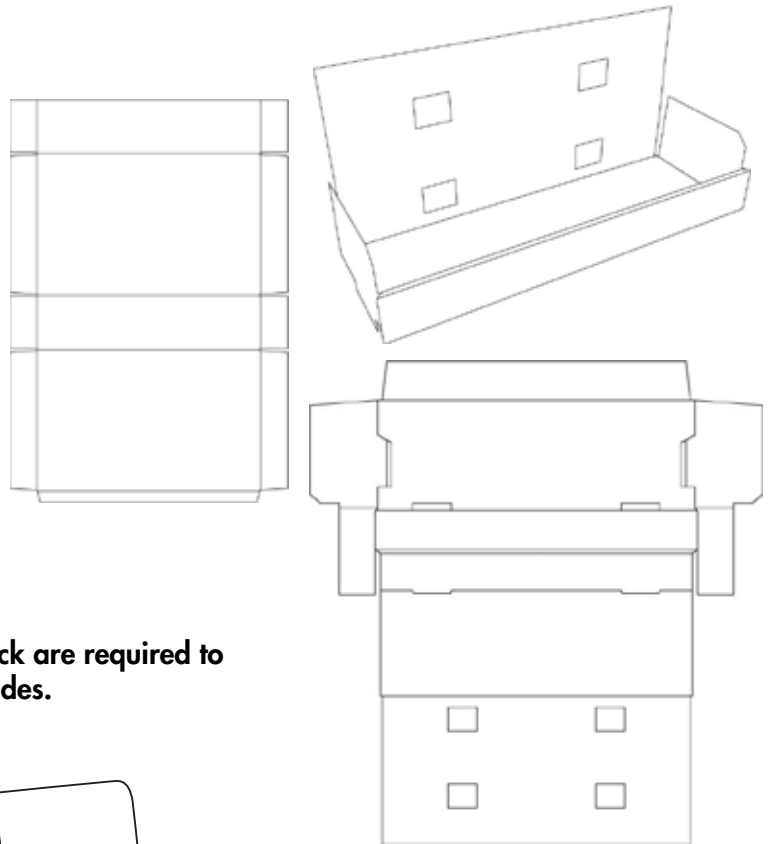

1" W x 2" T

Power Wing Clip

- Holds corrugated display on our Wire Rack
- Holds 1/8" B-Flute corrugate
- Each sidepanel must have a minimum of 4 clips

Heavy Duty Construction Requirements for Side Kicks

- Under 5 lbs is considered Light
- 6-15 lbs is Medium
- 16-20 lbs is Heavy (Requires Heavy- Duty Constuction, see considerations below)
- Display reviewed by a Packaging Engineer for overall better construction and/or material
- All four sides of the Side Kick are required to have Rollover Reinforced Sides.
- More and/or better hardware
- Void filler inserts to help restrict movement of product within display

Heavy Duty Partitioned Side Kick w/Reinforced Front & Side Panels

For heavier or bulky items (16 lbs. or greater but still less than 20 lbs.), we recommend this PDQ.

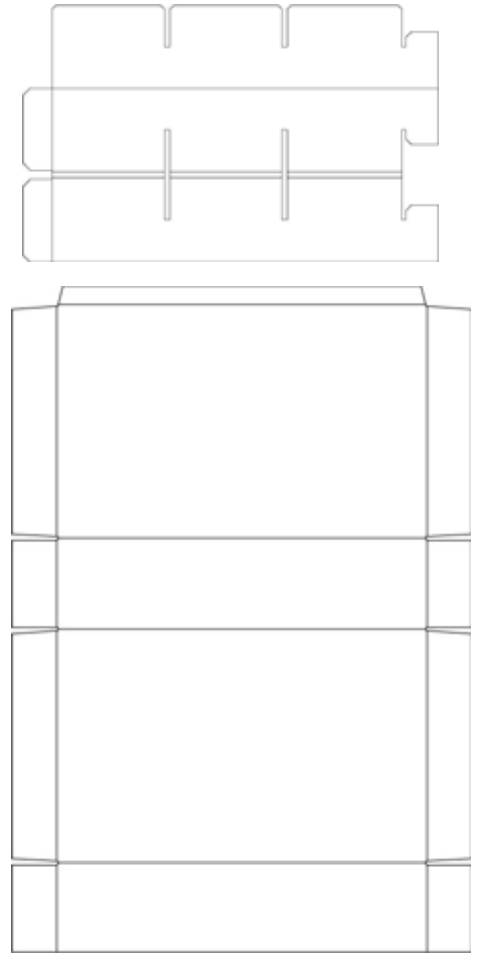
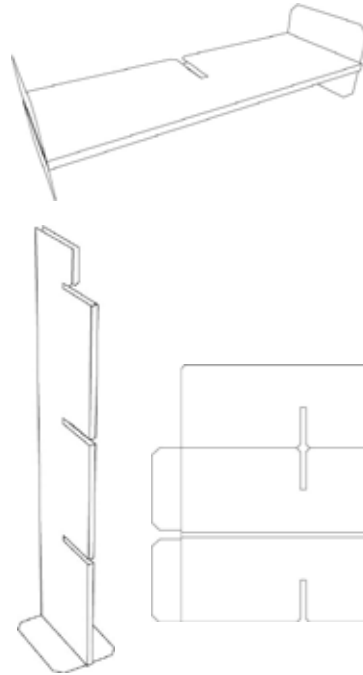
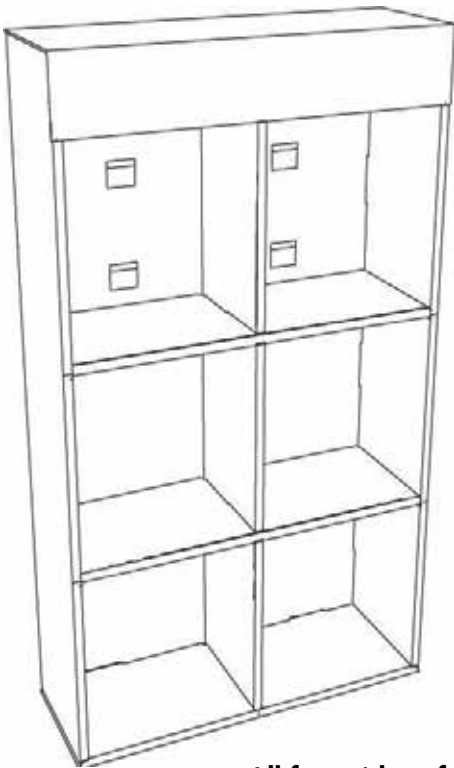

All four sides of the Side Kick are required to have Rollover Reinforced Sides.

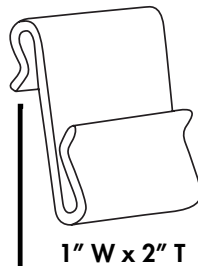
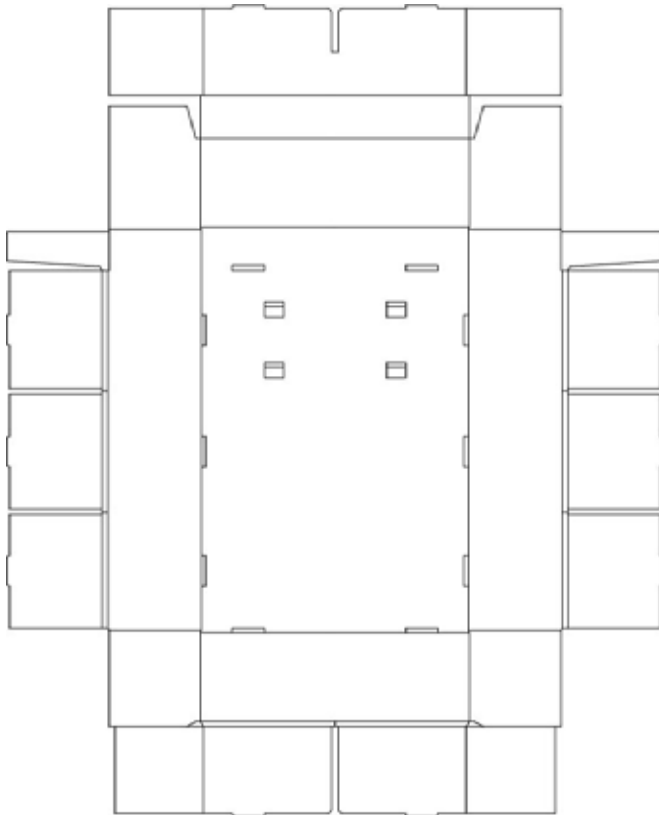

Power Wing Clip

- Holds corrugated display on our Wire Rack
- Holds 1/8" B-Flute corrugate
- Each sidepanel must have a minimum of 4 clips

1" W x 2" T

Heavy Duty Construction Requirements for Side Kicks

- Under 5 lbs is considered Light
- 6-15 lbs is Medium
- 16-20 lbs is Heavy (Requires Heavy- Duty Constuction, see considerations below)
- Display reviewed by a Packaging Engineer for overall better construction and/or material
- All four sides of the Side Kick are required to have Rollover Reinforced Sides.
- More and/or better hardware
- Void filler inserts to help restrict movement of product within display

Heavy Duty Peggable Side Kick w/Reinforced Front & Side Panels

For heavier or bulky items (16 lbs. or greater but still less than 20 lbs.), we recommend this PDQ.

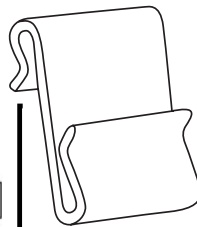
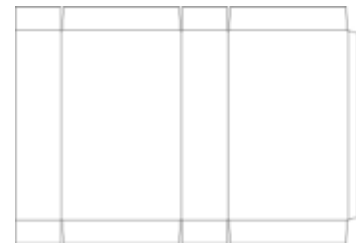
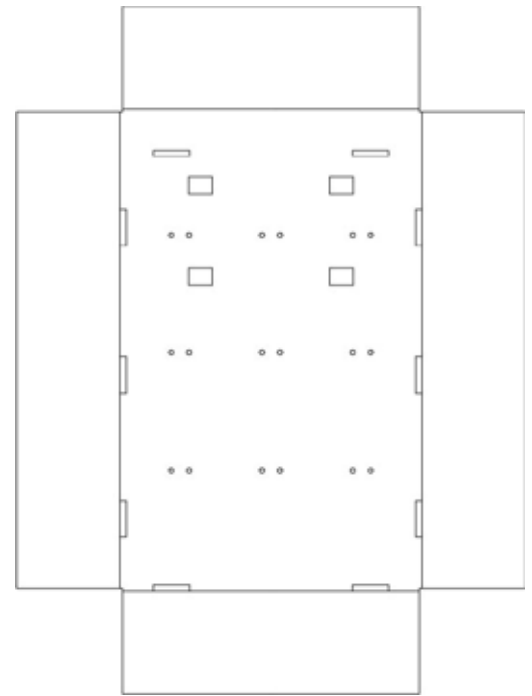
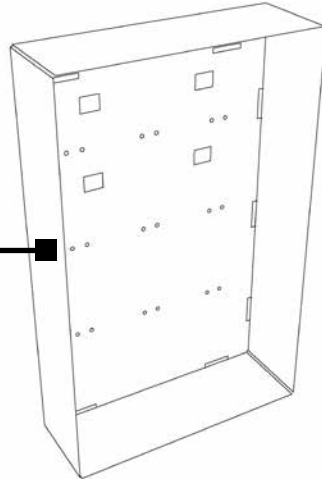
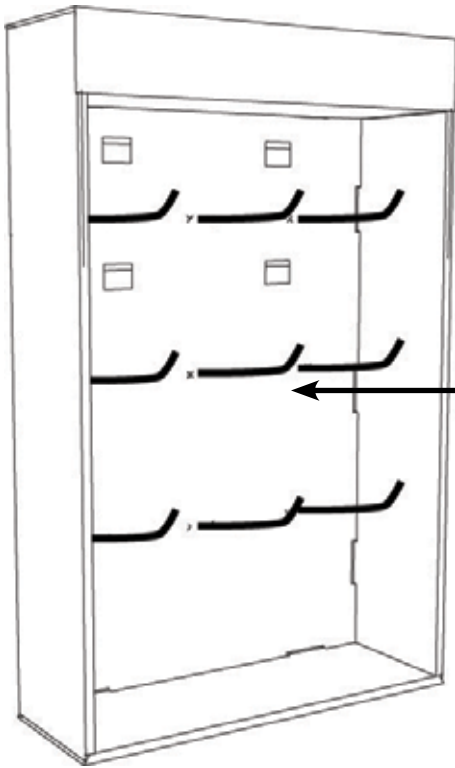

1" W x 2" T

Power Wing Clip

- Holds corrugated display on our Wire Rack
- Holds 1/8" B-Flute corrugate
- Each sidepanel must have a minimum of 4 clips

Heavy Duty Construction Requirements for Side Kicks

- Under 5 lbs is considered Light
- 6-15 lbs is Medium
- 16-20 lbs is Heavy (Requires Heavy- Duty Constuction, see considerations below)
- Display reviewed by a Packaging Engineer for overall better construction and/or material
- All four sides of the Side Kick are required to have Rollover Reinforced Sides.
- More and/or better hardware
- Void filler inserts to help restrict movement of product within display

GENERAL RECOMMENDATIONS

Displays shall utilize protective inserts to protect pegged product and restrict movement during distribution. Inserts may include, but not limited to: die-cut corrugated, peg-hook accessories.

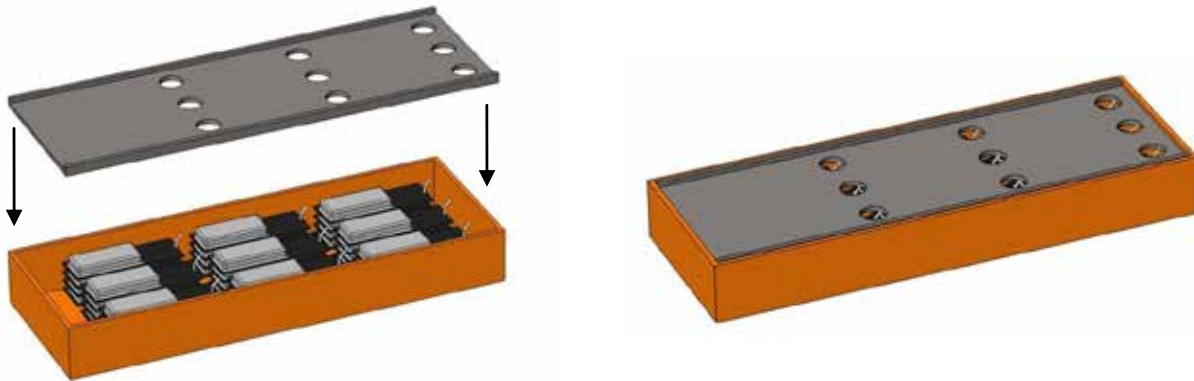

Above Image shows protective corrugated insert for shipping. This insert holds down pegged product to restrict movement and also nests over the display pegs to provide additional support of the pegs and to limit movement of the peg hooks.

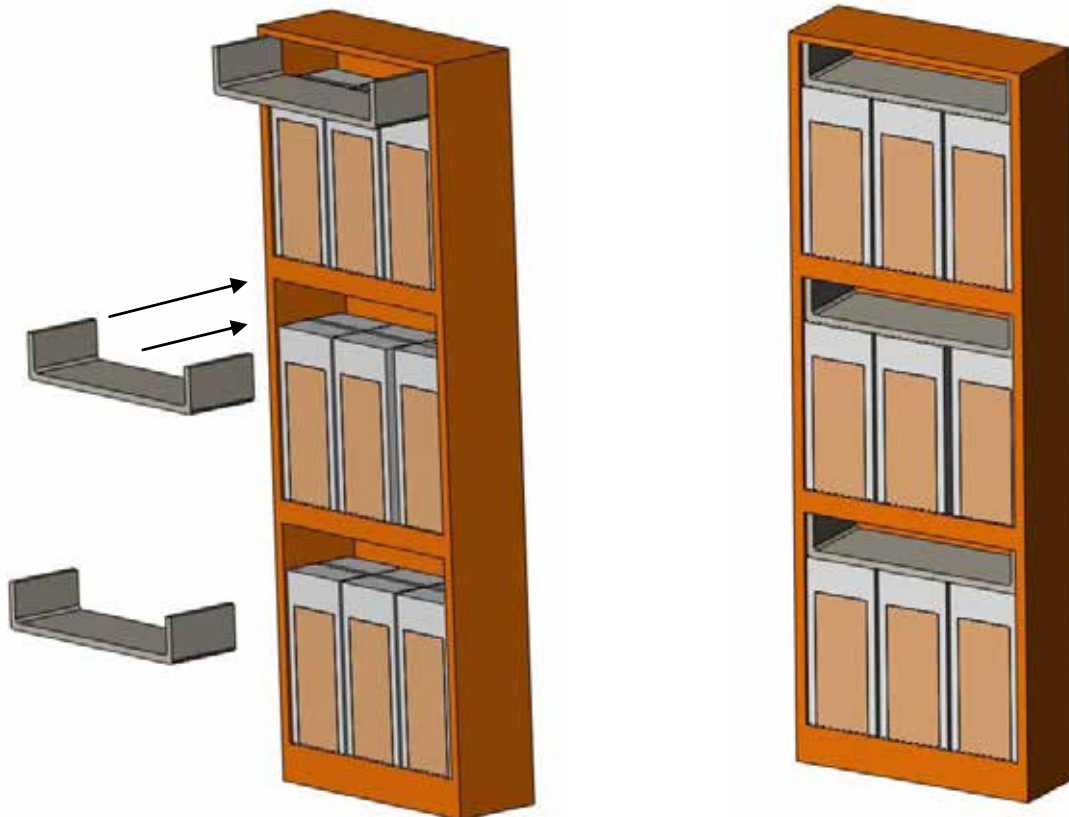

Void fill inserts shall be used to help restrict movement of product within the display. Void fill inserts are to be removed from the display at the retail store level and are not intended to provide additional structural support during the selling cycle period of the display. Corrugated roll-ups are preferred for void fill materials.

GENERAL RECOMMENDATIONS cont'd

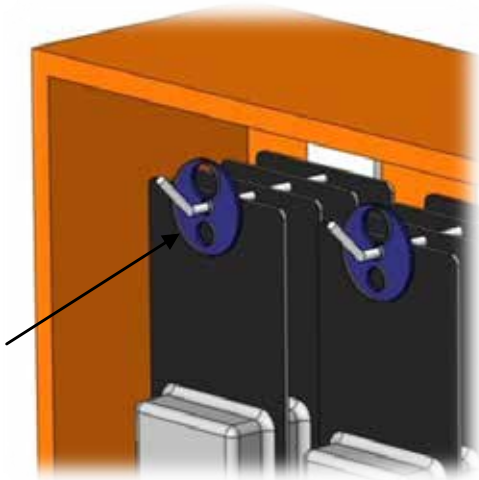

Accessory product stops restrict movement of product during shipment and keeps it on peg hooks. Example shown is for standard metal or plastic peg hooks

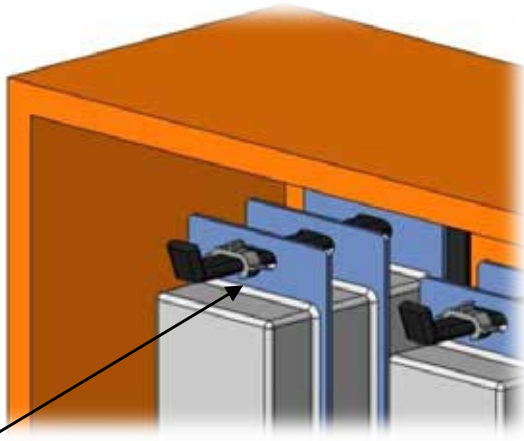

Accessory product stops restrict movement of product during shipment and keeps it on peg hooks. Example shown is for butterfly style peg hooks.

NOTE: Product can not “sag” on clip,
see guidelines below.

4" (10.16 cm) plastic hooks, no more than 1 lb per hook
5" (12.7 cm) plastic hooks, no more than 3/4 lb per hook
6" (15.24 cm) plastic hooks, no more than 1/2 lb per hook

GENERAL CONSTRUCTION

Heavier products shall utilize shelf dividers or similar structural support to help distribute the weight of the product across the full shelf. Dividers will help maintain the structural integrity of the display throughout the sell cycle period.

Display dividers shall be flood coat printed to match the color of the Side Kick display.

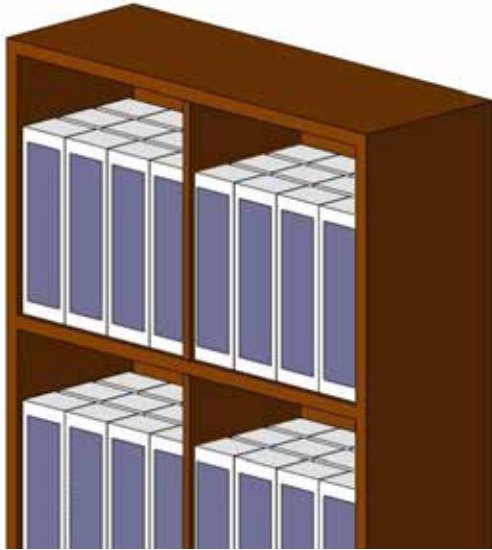

Side Kick Display with dividers

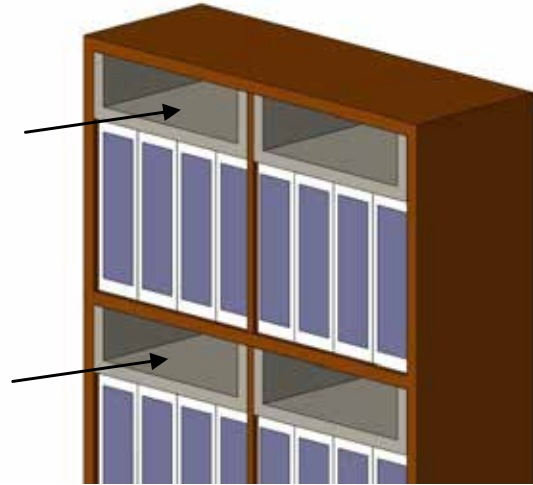

Divider side kick with void fill inserts for shipment

All four sides of the Side Kick are now required to have Rollover Reinforced Sides.

Side Kick displays will be hung on existing wire rack structures or power bar supports.

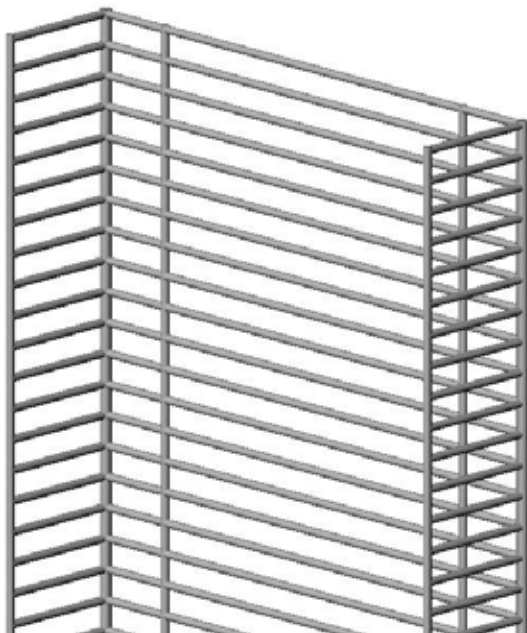

Wire Rack cage



Power bar support hung on shelf structure.

SIDE KICK MASTER CARTON

Side Kick's shall utilize end loading shippers. This style shipper allows for ease of loading and unloading at store level, and also utilizes minimal material required for the shipper box. See page 6-8 for proper carton marking icons.

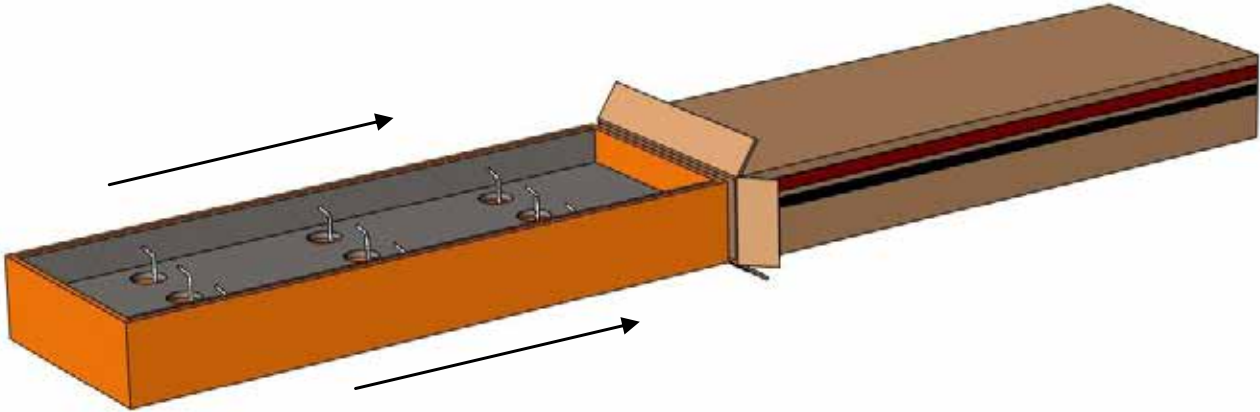

Load Side Kick display into shipper as shown

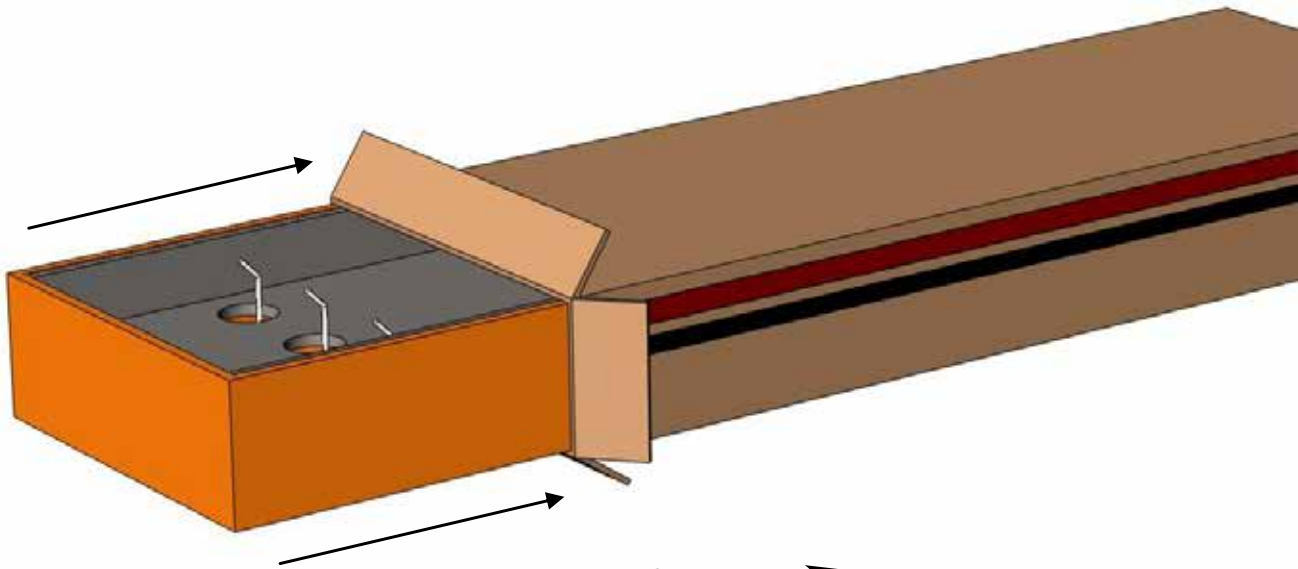

Flute Direction for End Load RSC

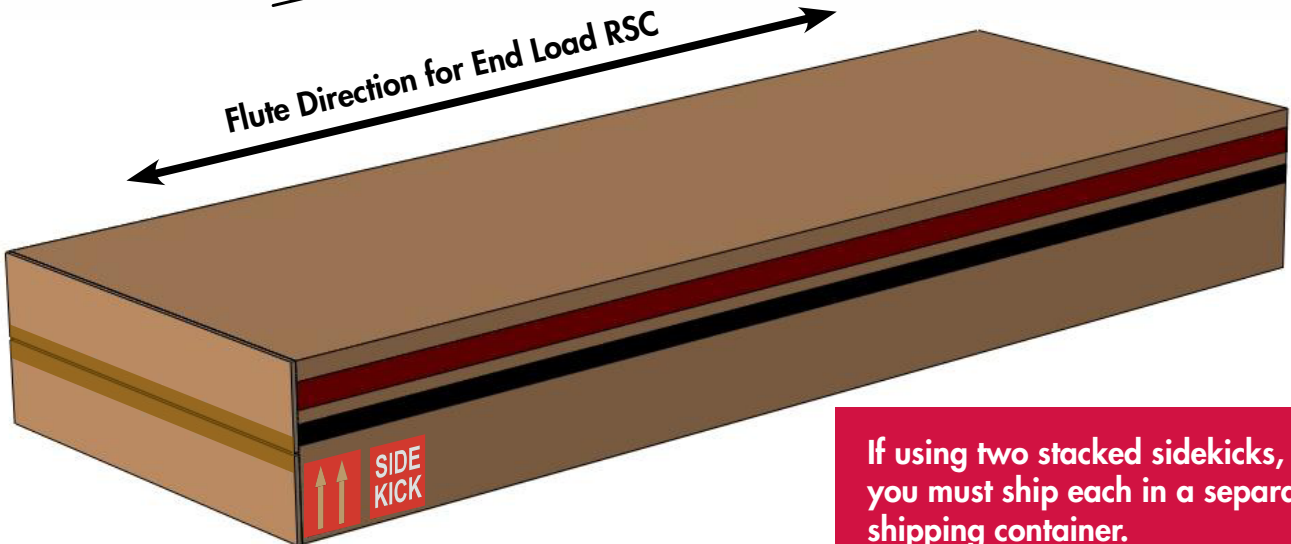

If using two stacked sidekicks, you must ship each in a separate shipping container.

SIDE KICK MASTER CARTON

Three good reasons to use a End Load RSC Box for Side Kicks:

- 1). End Load RSC is 16% less expensive than Top Load RSC
- 2). Easier to pull display out of an End Loaded RSC box
- 3). End Load box will use less tape

Standard Side Kick Size: 47 x 17 x 6"

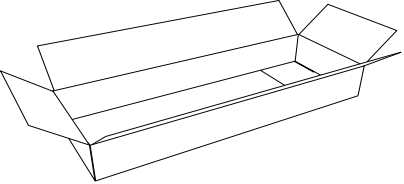
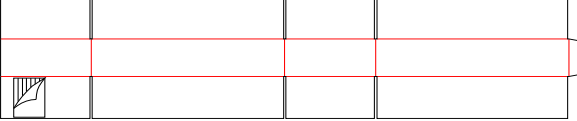
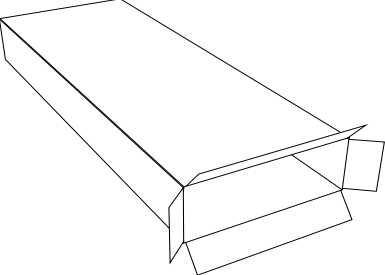
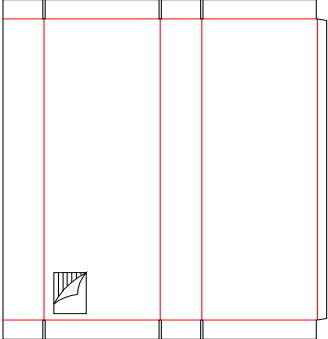
| Description | 3D Rendering | Flat Layout | Blank Size (sq in) | % Less Material |
|--------------|---|--|--------------------|-----------------|
| Top Load RSC |  |  | 3118.5 | - |
| End Load RSC |  |  | 2622 | -16% |

Peel back shows direction of flute

PROPER LOADING OF SIDE KICKS

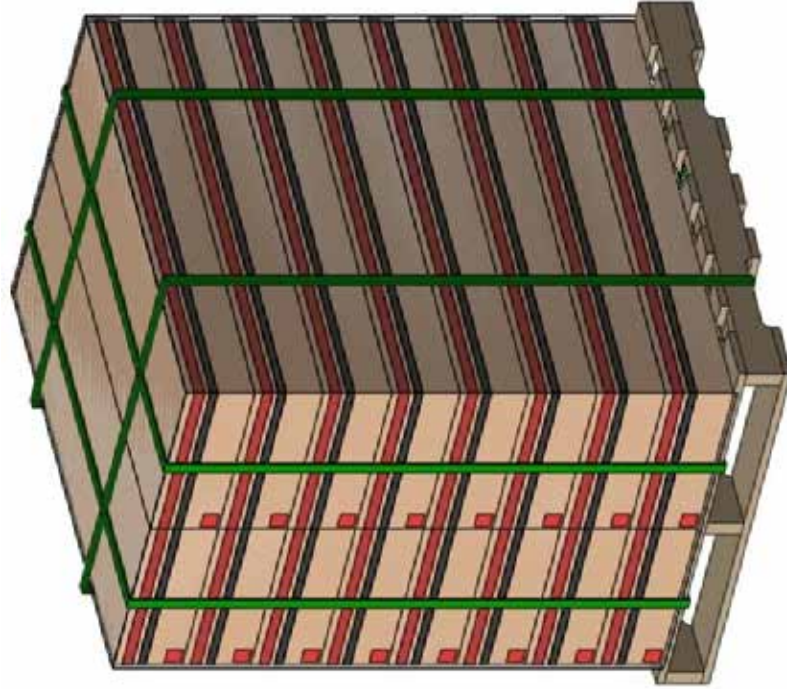

Image shows proper loading for incoming pallet shipments. Side Kick displays shall be column stacked when possible. Pallet shipments shall utilize stretch wrapping and banding to properly restrain the master cartons during distribution throughout the supply chain. A minimum of 80 gauge stretch film, wrapped three times or the equivalent in performance is required.

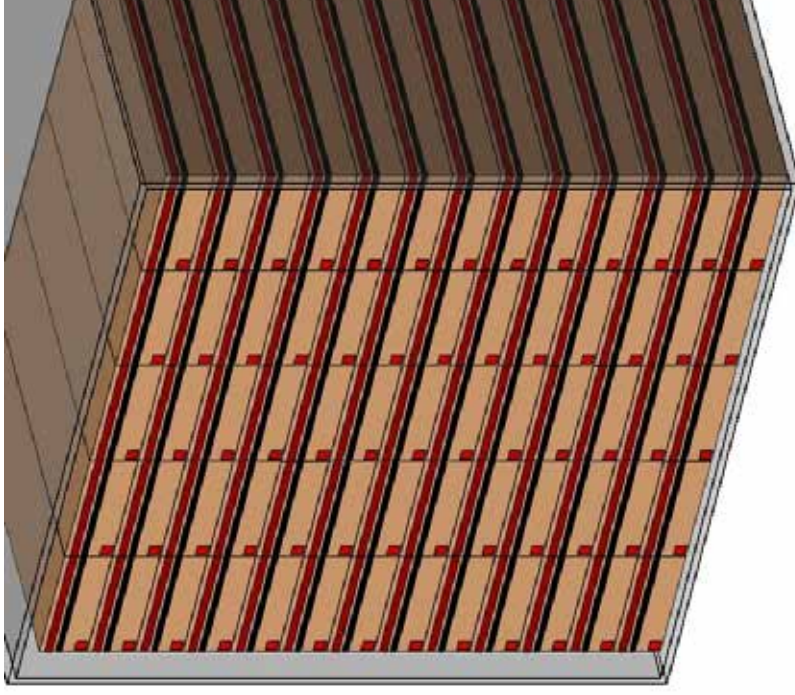

Image shows proper floor loading for incoming sea container shipments for import Side Kick displays. Side Kicks shall be shipped flat and column stacked. This provides the best stacking of strength and also helps to limit the movement of the product inside the display. Use void fill material within the container to prevent shifting or movement of the master cartons during transit to ensure the displays arrive in good condition.

NEW STANDARDS – Side Kicks: Hooks for Hanging Product on Corrugated Displayers

**DO NOT USE
OVER THE TOP HOOK**



OVER THE TOP HOOK -
As this hook gets weighed down by the product, it causes the clip to lift from where it attaches to the corrugate. This lets product slide down the hook, adding more pressure to the clip and tearing the corrugate.

**DO NOT USE
HOOK WITH PRONGS**



HOOK WITH PRONGS - Same disadvantages as the OVER THE TOP HOOK above

**USE
PPC HOOK**



PPC HOOK - When product is hung on this hook, it causes the clip to press against the corrugate above the hook. This keeps the front end of the hook from falling down, and keeps product from sliding off.

**USE
BUTTERFLY HOOK**

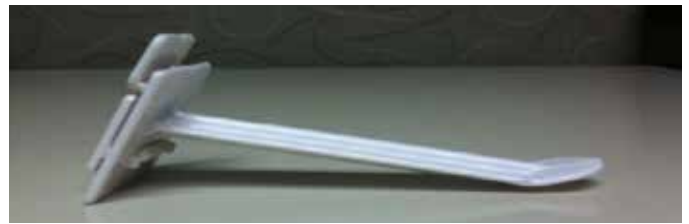

BUTTERFLY HOOK - Same benefits as the PPC HOOK above, but with a wider front hook.

4" (10.16 cm) plastic hooks, no more than 1 lb per hook
5" (12.7 cm) plastic hooks, no more than 3/4 lb per hook
6" (15.24 cm) plastic hooks, no more than 1/2 lb per hook

SIDE KICK Construction



NO!



Construction was weakened by design of this Side Kick.

- From the side, the bottom is much wider than the top, therefore there is no structural support for corner of Side Kick
- Too much weight on each hook
- Product is too heavy for each hook and therefore sliding off hooks
- Hooks are too close to top edge

BIG LOTS! Shelf PDQ Standards /// PDQ Construction

Side Kick STANDARDS

All four sides of the Side Kick is now required to have Rollover Reinforced Sides.

Minimum Material Specifications:

- 32 ECT (Edge Crush TEST*) OR 200# (Mullen Test**) Bleached white outside liner B-flute + Scuff-Resistant Varnish

Minimum Liner Combination:

- 175 gsm (35#) liner x 112 gsm (23#) medium x 175 gsm (35#) liner

Dimensions:

- Minimum Height is **25" (63.5 cm)**
- Maximum Outer Dimension (OD): **17" W x 6" D (43.18 cm x 15.24 cm)**
- Maximum Weight: 20 lbs

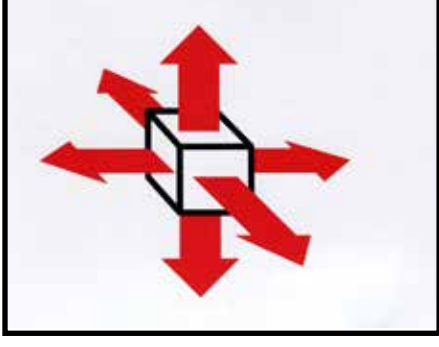

Transit Testing:

- See page 56 for Big Lots Transit Testing Standards.

Testing Protocol for Side Kicks:

ISTA (International Safe Transit Association) Test 2A

- For more information on ISTA: International Safe Transit Association
1400 Abbott Road, Suite 160
East Lansing, Michigan 4823-1900
USA
Phone: 1-517-333-3437
Fax: 1-517-333-3813
ista@ista.org

NOTE: Side Kick displays must be able to be shipped in any orientation.

NOTE: SIDE KICKS ARE EXPECTED TO SURVIVE 13 TOUCH POINTS IN SUPPLY CHAIN AND LAST 9-14 WEEKS ON STORE FLOOR.

* **Edge Crush Test (ECT)** - The Edge Crush Test is a standard industry measure of the stacking strength or corrugated board.

** **Mullen Test** - The Mullen Test is a standard measure of the bursting strength of corrugated board.

SIDE KICK

Master Carton Marking Icons



This icon communicates **SIDE KICK** display to the DC associate. DC associate will then avoid stacking other heavy boxes onto the **SIDE KICK** display/product when loading our trucks to avoid damaging the **SIDE KICK**.

SIDE KICK - DO NOT STACK HEAVY PRODUCT ON TOP OF

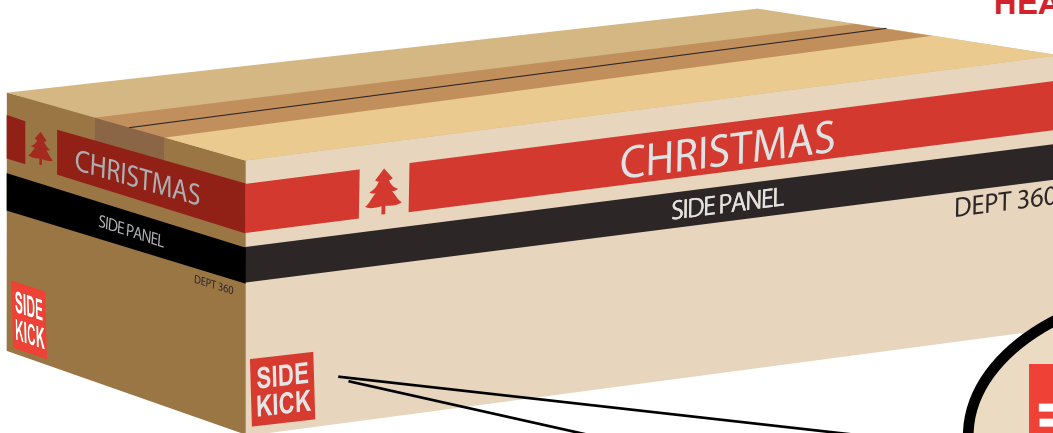

Example Only

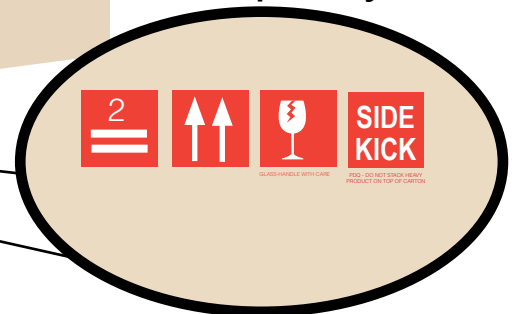

NOTE: Carton marking icons are required to be placed on at least four different sides of the Master Shipping Carton. If the master shipping carton contains a casepack of one then the carton marking icons are also required on at least four different sides of the box. See Carton Marking Icon Sizing Chart (page 9) for appropriate size carton marking icon(s).

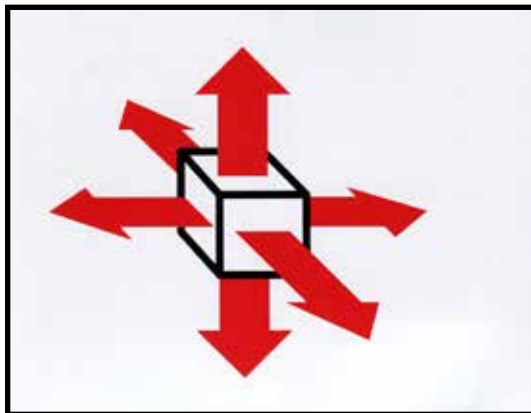

NOTE: Side Kick displays must be able to be shipped in any orientation.

- Required Carton Markings Document and icons can be found on our website at:
<http://www.biglots.com/corporate/vendor-relations/vendor-routing-and-compliance>

NOTE: For questions on Carton Markings contact vendorcompliance@biglots.com



———— **FLOOR DISPLAY STANDARDS** ————

BIG LOTS FLOOR/PALLET STANDARDS

FLOOR/PALLET DISPLAY DESIGN APPROVAL PROCESS: Every Floor Display must go through each step in this process. Big Lots reserves the right to charge back any vendor that produces incorrect or inferior Floor Displays that have not completed this process.

1. A white pack out sample is required to be submitted for review and approval by the Columbus Packaging Team for all Domestic Orders. At this step in the process, Big Lots reserves the right to request any design changes. Recommended design changes will be sent to the vendor via email. Additional information that needs to be included with the white packout sample is Article# and Case Pack. **Be sure to allow time in this step for corrections as needed.**

If the white pack out sample is approved, go to step 2. If the sample is not approved, you will need to make revisions as necessary and re-submit a new folded sample.

NOTE: A sample is not required for close-out items.

2. Once the revised white pack out sample is approved, send the electronic artwork layout on the Side Kick dieline artwork layout should be provided to **packaging@biglots.com**

3. Once the electronic artwork layout has been approved, a color print/press proof is required. This proof must show the exact colors to be printed in mass production and be on the same corrugate (color and weight) to be used in mass production. An ink draw down swatch with Varnish on the actual corrugate is also acceptable, at this stage. If you require a signed print proof to be sent back to you, please send two.

If the proof is approved, go to step 4. If the proof is not approved, you will need to make revisions as necessary and re-submit a new proof. Be sure to allow time in this step if corrections are needed.

White pack out samples & print proofs should be sent to:

Big Lots Corporate Office
ATTN: PACKAGING DEPT
4860 E. Dublin Granville Road
Columbus, Ohio 43081

4. Floor Displays will require testing prior to mass production. See page 56 for transit testing requirements.

5. Begin mass printing after Transit test has passed. Vendors are required to send one final printed Floor Display (please ship this sample flat packed for our files) sample to Big Lots or Big Lots Agent. Send it to the same address as in step 3 above. **If a buyer requires a sample, an additional sample should be sent separately to their attention.**

If you have any questions you may email us at packaging@biglots.com.

NOTE: FLOOR/PALLET DISPLAYS ARE EXPECTED TO SURVIVE 13 TOUCH POINTS IN OUR SUPPLY CHAIN AND LAST 9-14 WEEKS ON STORE FLOOR.

BIG LOTS FLOOR & PALLET DISPLAY STANDARDS continued

FONT SIZES:

Futura Heavy - Used for the Item Description

ABCDEFGHIJKLMNOPQRSTUVWXYZ

abcdefghijklmnopqrstuvwxyz

- Use Futura Heavy for upper and lower case (all white lettering)
- 68 pt. for 24" (60.96 cm) with one line descriptor (Item Description size can vary based on size.)
- If the item description will not fit at 68 pt., you may reduce it to no smaller than 55 pt. and stack it

Futura Bold - Used for the Retail Price

0123456789 \$

- For Retail Price Futura Bold all upper case (all white) 100 pt. type
- For Dollar Sign Futura Bold all upper case (all white) 55 pt. type, aligned with the top of the retail price.
- There should be a 1" (2.54 cm) space between the last number of the price and the right edge of the color Stackable PDQ

Note: If the retail price is a whole number, use ONLY the dollar sign and amount

\$5 right

\$5.00 wrong

- If retail is under \$1, use ONLY the decimal point and amount in Futura Bold 100 pt. type (all white)
.99 right
.99¢ wrong

- Do NOT use the decimal point if the retail price is not a whole number. Cents in Futura Bold 55 pt. type (all white), aligned with the top of the retail price

^{\$1⁵⁰} right

\$1.50 wrong

REQUIRED TRANSIT TESTING FOR **ALL FLOOR/PALLET DISPLAYS ONLY**

The purpose of the ISTA testing is to make sure merchandise flows through the supply chain and out into the retail stores without damage. Our goal is to reduce complaints, increase product sales and not have to re-merchandise 1500 stores (store labor).

All Floor/Pallet displays (includes Stackable PDQ), now require ISTA 3E transit testing.

For Import Vendors Assigned to an Agent - You will be required to have the Side Kicks and Floor/Pallet Displays tested with their designated testing facility prior to mass printing/production.

For National Branded Vendors (Imported Purchases) - You will be required to have the Side Kicks and Floor/Pallet Displays tested with Bureau Veritas prior to mass printing/production. Send all passed Transit Test reports to packaging@biglots.com for our review prior to proceeding to mass production.

For Domestic Importers with FOB U.S.A - You will be required to have the Side Kicks and Floor/Pallet Displays tested with an ISTA (International Safe Transit Association) Certified Lab prior to mass printing/production. Please refer to www.ista.org to locate a certified lab in your area. If a vendor chooses one of the following testing facilities: BV, Intertek or SGS notify deannataylor@biglots.com. Submit all **“passed”** test reports to packaging@biglots.com for approval prior to mass printing/production.

For Items Purchased Domestically (Including National Branded Vendors) - You will be required to have the Side Kicks and Floor/Pallet Displays tested with an ISTA Certified Lab prior to mass printing/production. Please refer to www.ista.org to locate a certified lab in your area. Submit all **“passed”** test reports to packaging@biglots.com for approval prior to mass printing/production.

NOTE: Allow 2 weeks for testing and another week to obtain final test report.

NOTE: ALL DISPLAYS ARE EXPECTED TO SURVIVE 13 TOUCH POINTS IN SUPPLY CHAIN AND LAST 9-14 WEEKS ON STORE FLOOR.

FLOOR DISPLAY STANDARDS

Allow approximately 4 months to create display from design to completion of mass printing.

Definition of a shoppable display:

- Able to easily see the assortment (color and sizes of a given item)
- The ability to pull the item from the display without damaging and/or without having to move pieces of the display to get item out.

What to Consider When Designing a Floor Display:

- Consider the life of the display in store as this will help the designer determine the appropriate corrugate. Displays are expected last 9-14 weeks on store floor.
- Identify where the display is going to be located.
- Determine with Big Lots buyer how many sides display will be shopped in the store
- What size pallet is needed for the display
 - Quarter - 24" x 20" (60.96 cm x 50.8 cm)
(Maximum Weight Limit of Display is 80 lbs)
 - Half - 40" x 24" (101.60 cm x 60. cm)
 - Full Pallet - 48" x 40" (121.92 x 101.60)
- Corrugator will need samples and case pack of each item to design display.
- How many colors will be printed on the display?
- Is there any items that should be prominent on display?
- Able to reach in and pull out item without display collapsing.
- Product not falling forward after partially shopped.

What to Consider When Quoting a Floor Display:

- How many stores will this display reside in?
- Will display be flat packed and shipped?
 - Assembly instructions will need placed inside each box
- Will display ship assembled and loaded?
- Required Transit Testing, see page 56.

Performance and Transit Testing:

Prototype testing is absolutely critical, and must be conducted by an ISTA certified facility. While the overall appearance of the display is very important, it is not an indicator of how well the merchandise will be protected in shipping, from the manufacturer, and out to our stores. It also does not indicate how well the unit will withstand the duration of its in store use.

Shoppable Display



NOTE: ALL DISPLAYS ARE EXPECTED TO SURVIVE 13 TOUCH POINTS IN SUPPLY CHAIN AND LAST 9-14 WEEKS ON STORE FLOOR.

GENERAL FLOOR DISPLAY GUIDELINES AND REQUIREMENTS

The following guidelines represent some displays and best practices; however the exact style and design may vary depending on the specific product involved. A proactive approach to designing a new display will help ensure the success of the display program as it reaches the retail stores.

Displays shall be designed to support the weight of the product through distribution and the supply chain as well as maintain integrity through the entire sell cycle period at the retail store. This period may last 9 to 14 weeks.

Preliminary graphic renderings, plan-o-gram images, or sample mock-ups are highly encouraged during the approval process

Please allow 4 months to allow full design, graphic art, testing, production, approval and refinements to be made prior to launch date of the display.

Displays are intended to be shop through style. This means that the product should not support any load of the display structure. Customers should be able to remove product from the display without having to alter the construction of the display or move components of the display.

Display may be 1, 2, 3, or 4 sides shoppable, depending on merchandising and buyer requirements.



Example: 1 side shoppable display. Customer is able to select product from 1 side only.

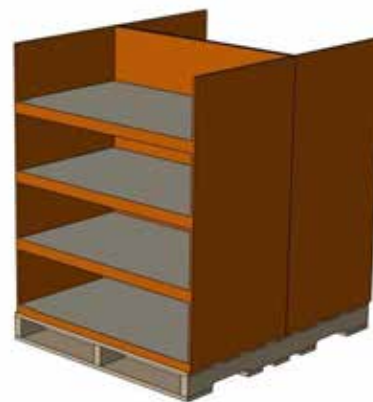

Example: 2 side shoppable display. Customer is able to select product from 2 sides.

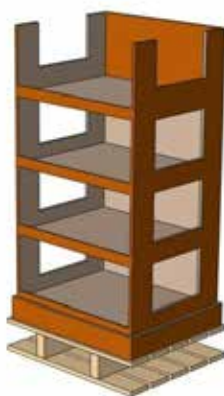

Example: 3 side shoppable display. Customer is able to select product from 3 sides.

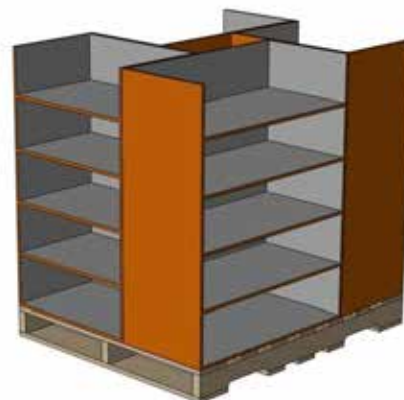

Example: 4 side shoppable display. Customer is able to select product from all 4 sides.

PALLET DISPLAY OPTIONS



Shop Through Display:

Shop through displays can include a mix of products. The product does not bear any load of the display or other products, which allows the consumer to pick and choose their product selection from multiple levels or positions within the display.

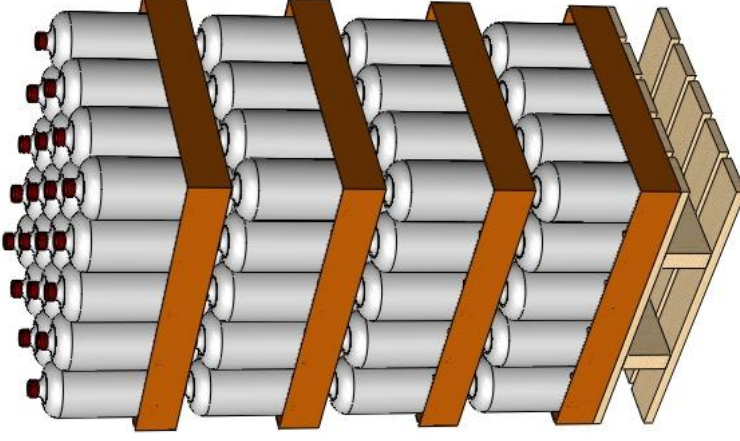

Shop Down Display:

Shop down displays are primarily used and allowed for displays that have the exact same product throughout the pallet. Each layer of the display bears the weight of the product layer above it, which requires the shopper to buy from the top layer and work down the display.

The use of display headers is allowed (but not required). Graphic headers shall be shipped knocked down flat, to be assembled and attached to the main display at the retail store.

PALLET REQUIREMENTS

Pallet displays must be engineered to withstand multiple fork lift and pallet jack touches.
 Pallet displays must be designed to withstand dynamic forces (vibration) from long distance transit (over 1,000 miles) without damage.
 Pallet displays shall be designed to withstand compressive load from mixed load product placed on top of the display during distribution to retail stores.
 Displays must be designed to withstand high humidity environmental factors without failure.

| Pallet Requirements: | | |
|---|--|---|
|  |  |  |
| Big Lots standard for pallets is: 4-way Pallet GMA B 48" x 40" | Chep, Peco and iGPS are allowed, but not preferred | Corrugated pallets are <u>not allowed</u> |
| Pallets should be of sound quality: free of debris, stains, odor and bugs. All stringers and deck boards shall be intact. No nails or fasteners shall be protruding | | |

Pallets must be engineered to fit the display and engineered to work with Big Lots pallet jacks (see photo reference below.)



Display Materials:

Minimum material requirements are 32 # ECT B flute or 200# Mullen Burst B flute

Paper combinations:

35lb (175g/m²) Liner / 26lb (125 g/m²) Medium / 35lb (175g/m²) Liner

B flute is typical for displays due to its high graphic quality and cost balance. Heavier paper combinations or specialty flutes, such as EB doublewall, may be required or utilized depending on various factors including (but not limited to) transit distance, product weight and density, display construction, compression requirements and environmental factors

QUARTER PALLET DISPLAYS

Quarter pallet displays size requirements:

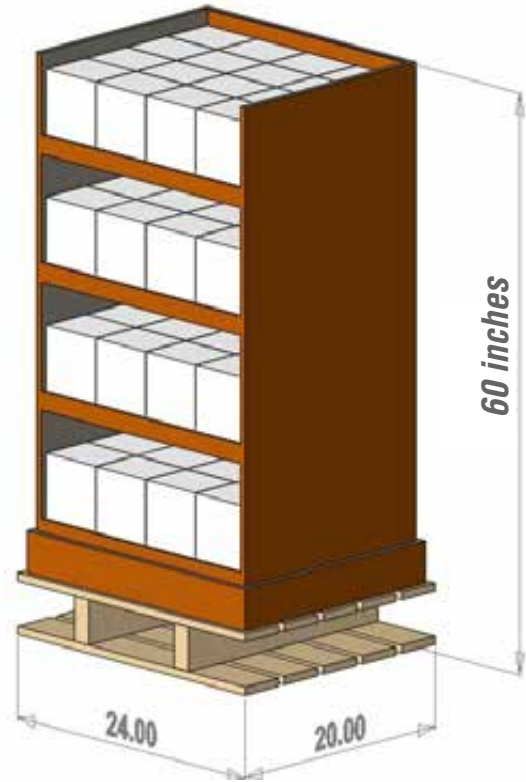
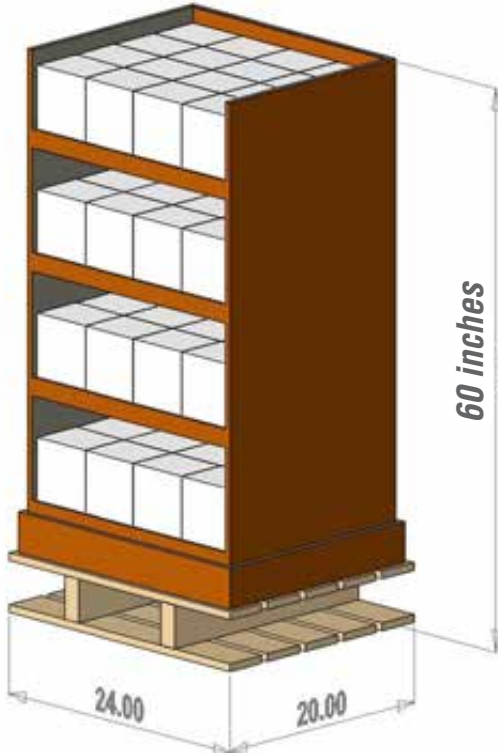

Import Displays- standard 40 foot sea container:
24" x 20" x 60" Tall (Including Pallet)

Import Displays – imported in 40 foot High Cube containers: 24" x 20" x 60" tall (Including pallet)

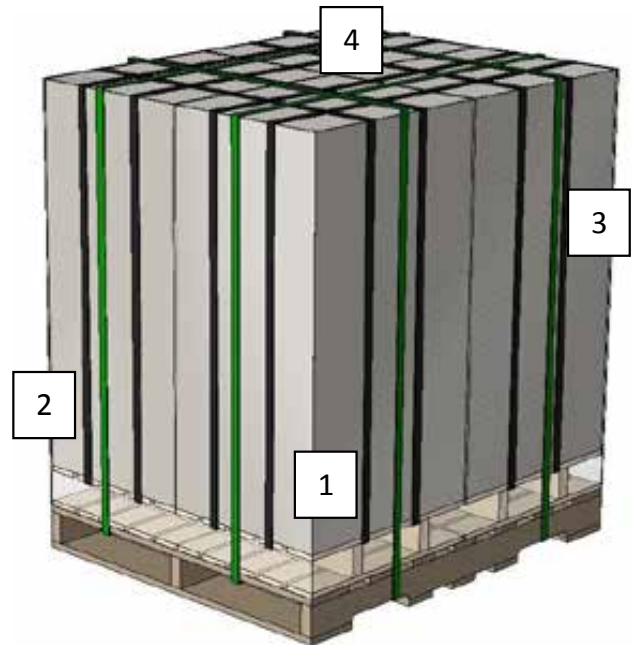
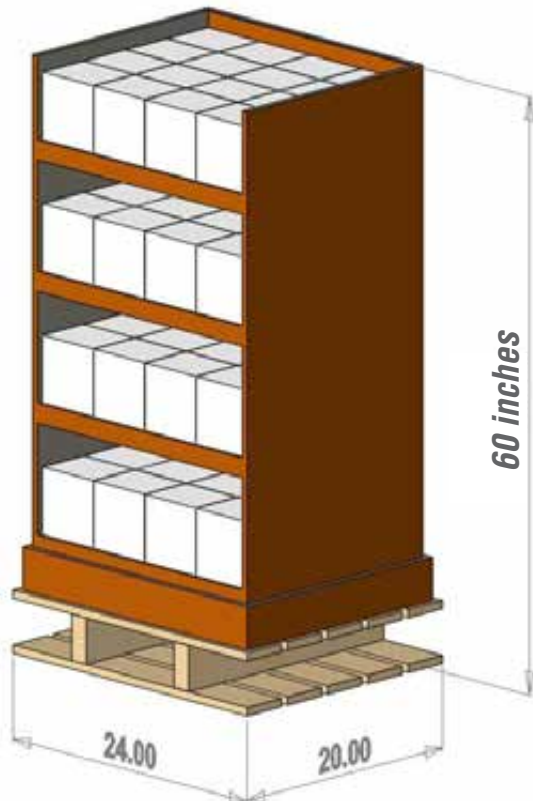

Domestic Displays: 24" x 20" x 60" tall (Including Pallet)

Incoming shipments must ship 4 Quarter Pallet units secured to a standard 48 x 40" pallet

HALF PALLET DISPLAYS

Half Pallet Displays Size Requirements:

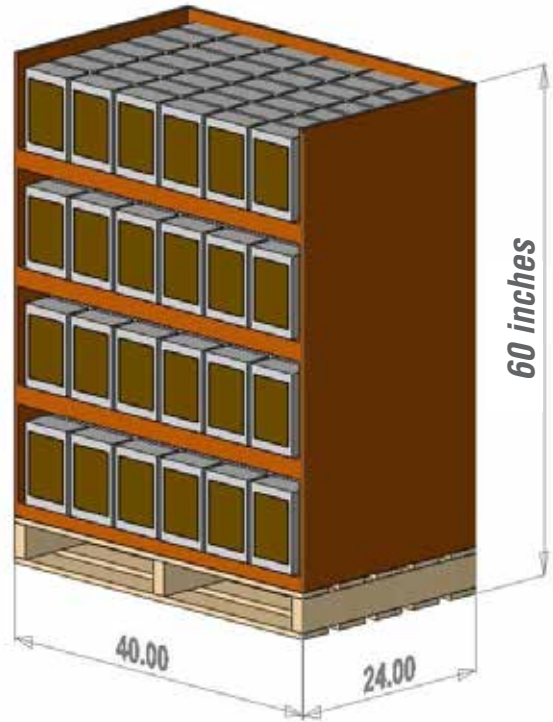
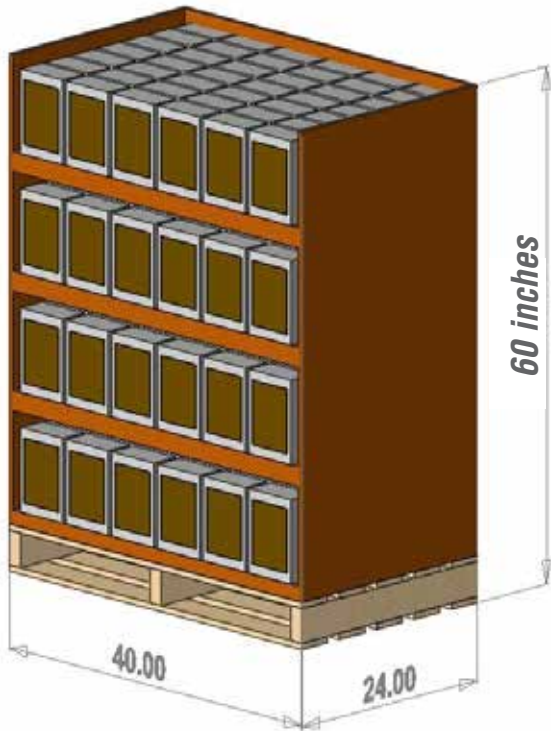

Import Displays - standard 40 foot sea container:
40" x 24" x 60" Tall (Including Pallet)

Import Displays – imported in 40 foot High Cube containers: 40" x 24" x 60" tall (Including pallet)

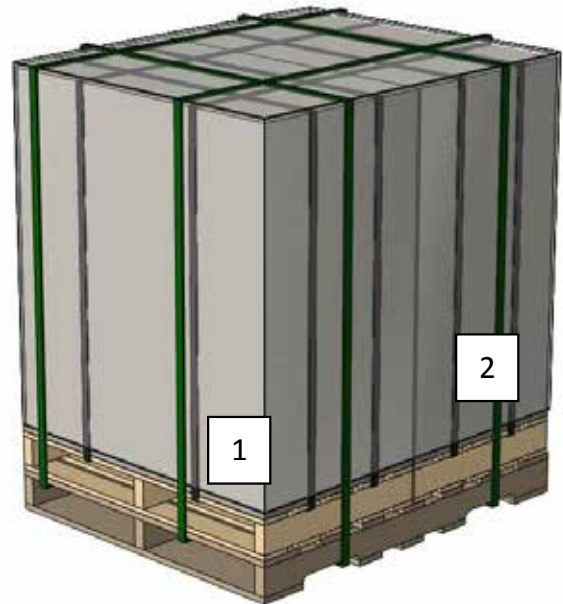
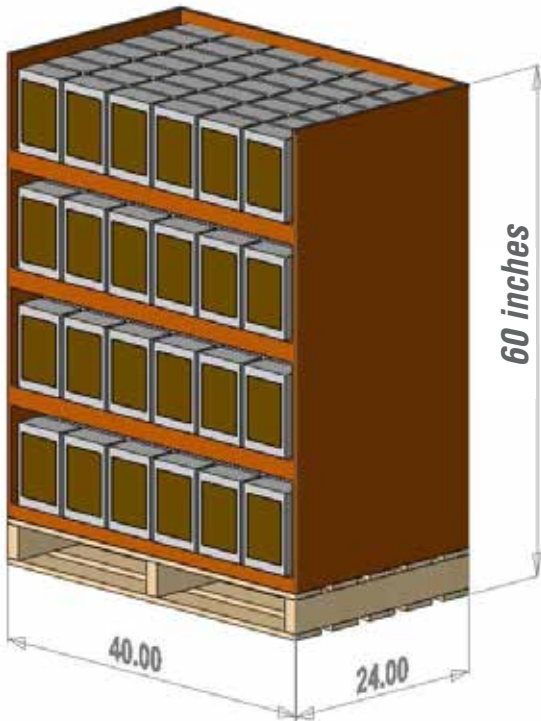

Domestic Displays: 40" x 24" x 60" tall (Including Pallet)

Incoming shipments must ship 2 Half Pallet units secured to a standard 48 x 40" pallet

FULL PALLET DISPLAYS

Full Pallet Displays Size Requirements:

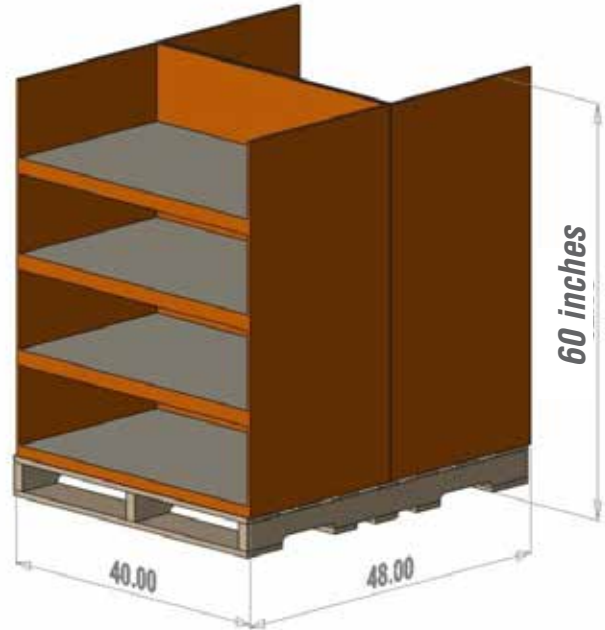
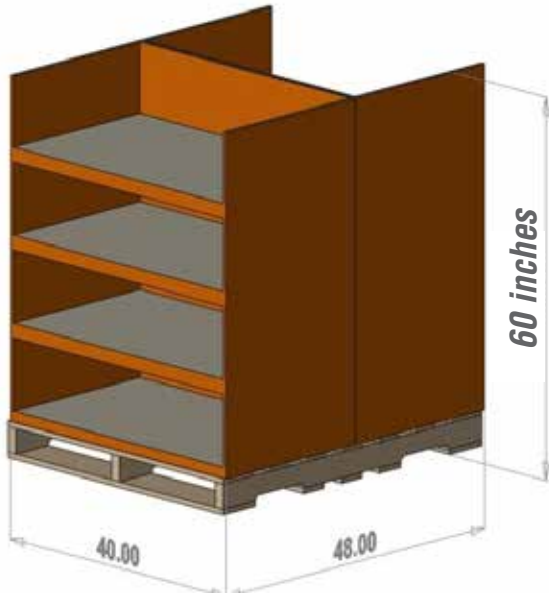

Import Displays- standard 40 foot sea container:
48" x 40" x 60" Tall (Including Pallet)

Import Displays – imported in 40 foot High Cube containers: 48" x 40" x 60" tall (Including pallet)

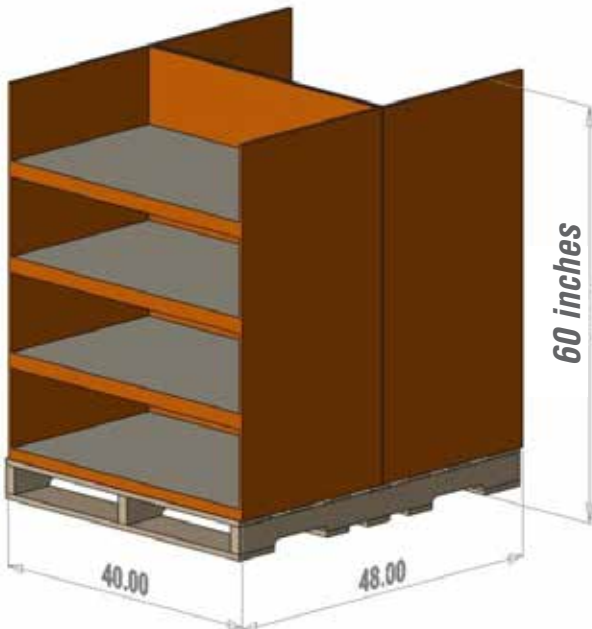

Domestic Displays: 48" x 40" x 60" tall (Including Pallet)

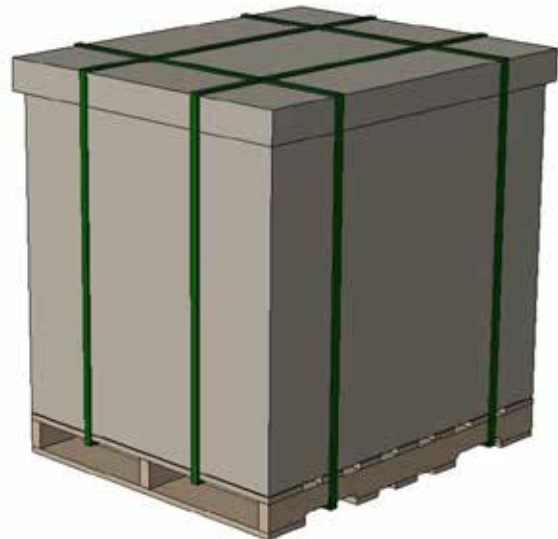
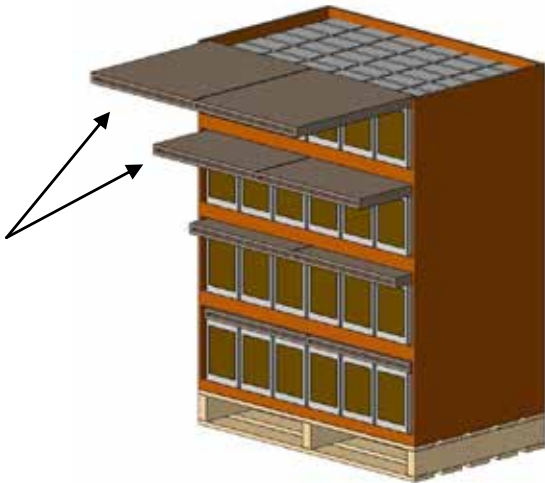

Image shows full pallet display with shroud, cap and banding.

SECONDARY PACKAGING

Secondary packaging includes any protective packaging used to help restrict movement of the product and protect the display during distribution and handling. Secondary packaging may include, but not limited to: void fillers, corrugated shroud and cap, corrugated HSC cover, stretch wrap, corner posts, banding & strapping and pallets.



Void fillers shall be utilized in shipment of displays to help restrict movement of the product inside the display during distribution

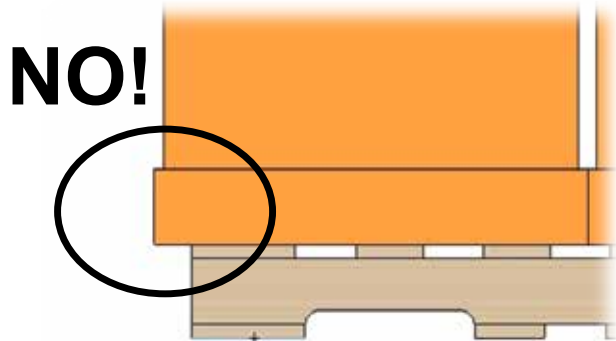

Display must NOT overhang pallet. Pallet overhang reduces the compression strength of the display and also increases the likelihood for damage during distribution handling.

Pallet displays shall utilize corrugated shroud and banding to properly restrain the display to the pallet during transit. Corrugated shrouds also help improve overall compression strength of the display and help prevent punctures to the display and packaged product during distribution handling.

Pallet displays without a corrugated shroud MUST utilize stretch wrapping and banding to properly restrain the display to the pallet during transit.

A minimum of 80 gauge stretch film, wrapped three times or the equivalent in performance is required

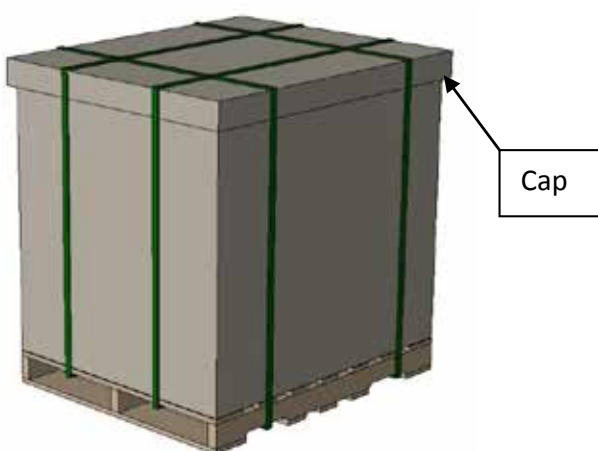

Pallet display with corrugated shroud, cap and banding. The top cap also protects the display from strapping and other cartons stacked on top of the display.

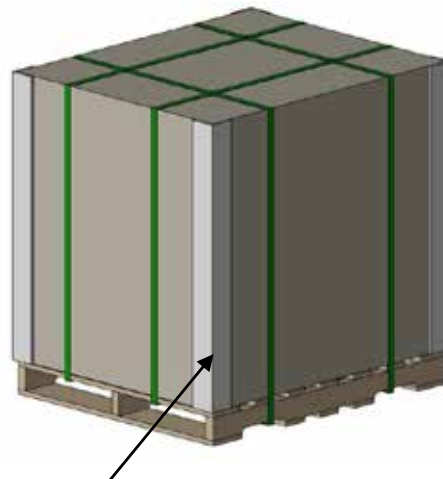

Corner boards added for additional protection and compression strength. Corner boards also protect the display from damage due to tight stretch wrap or strapping.

HARDWARE



Metal tube supports may also be used to provide additional strength support to display shelving. Metal tube supports may be used depending on product mix, shop-ability of the display and display plan-o-gram.

Image shows metal tube support in use. Support is typically ¾" aluminum tubing.

Style Recommendations/ Display Layouts:

Pallet display layouts to maintain 80% utilization of pallet footprint (only 20% "air space" allowed). Considerations for this requirement shall be made when determining the number of product facings, number of sides shop-able, and total number of products per display.

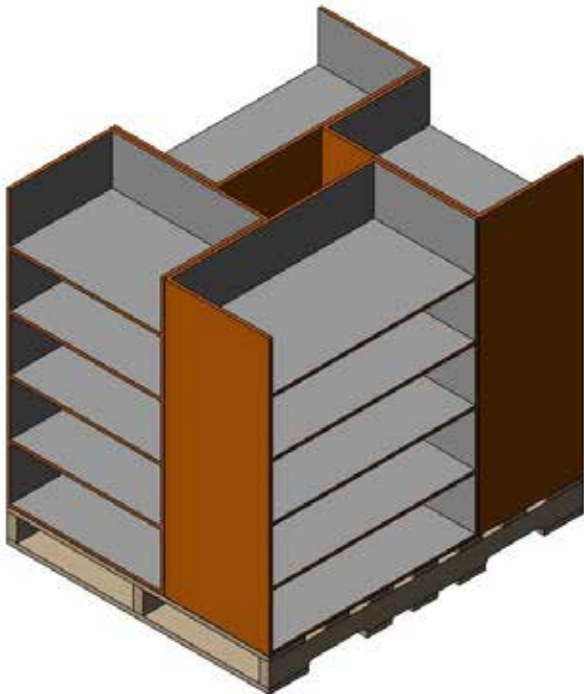
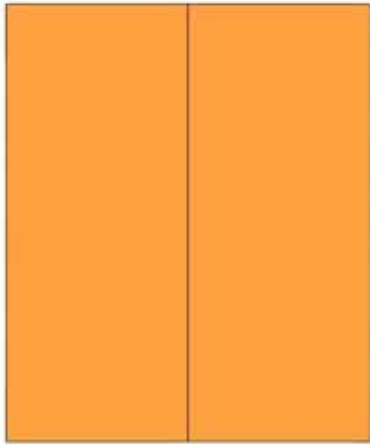
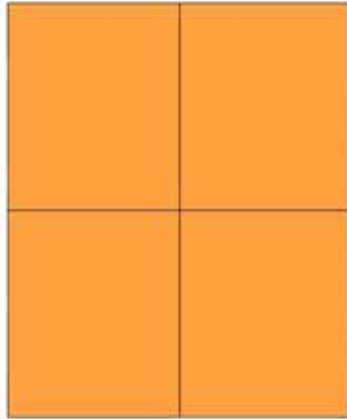

Image shows example of display layout with less than 20% open space in the center of the pallet display.

TOP VIEW OF PALLET LAYOUTS



Layout shows the Top View of two half pallet designs combined to make a Full pallet



Layout shows the Top View of four quarter pallet designs combined to make a Full pallet

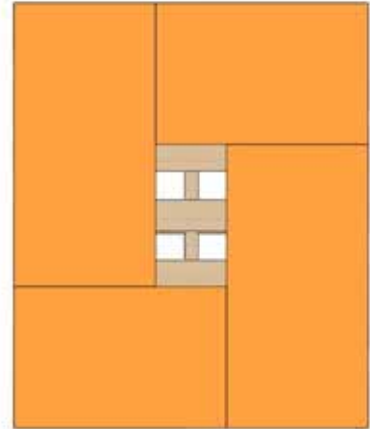

Image shows the Top View of potential pinwheel layout of Full pallet display.

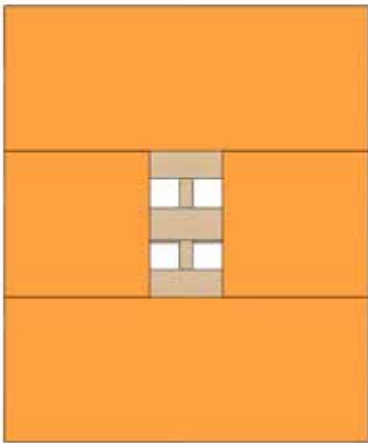

Image shows the Top View of potential layout of full pallet display.

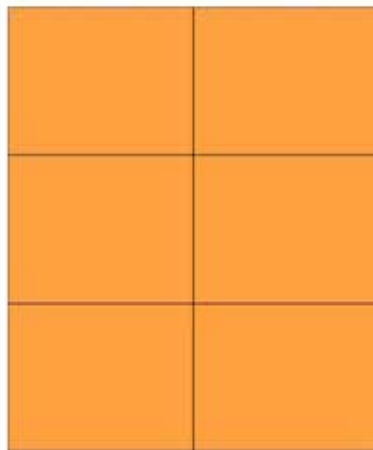

Image shows the Top View of potential layout of full pallet display.

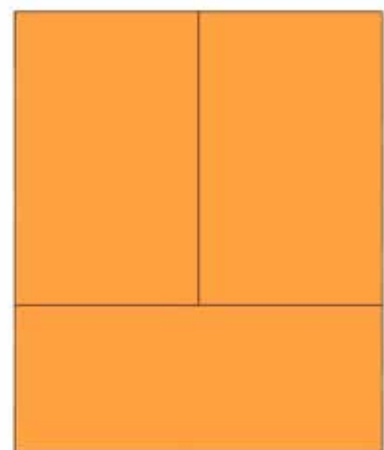

Image shows the Top View of potential layout of full pallet display.

Floor Displays: Best Practices

CURRENT



The display was a shop down display and was not built strong enough. When corrugate filler used to support the tray above was removed, the display began to collapse in store.

Corrugate void fillers are intended for restricting movement during shipping. Void fillers will be removed once the display reaches the retail store. They should not be intended to add any additional support to the display at the retail store level.

Displays must be constructed to hold the weight of the product once these void fillers are removed.

**Big Lots standard for pallets is:
4-way Pallet GMA B,
48" x 40" (121.92 cm x 101.6 cm)**

RECOMMENDED



Each tier has been designed to handle the weight of the merchandise and allows the display to be shopped, since each tier isn't resting on the product below.

Floor Displays: Best Practices

CURRENT



Weight of product is too heavy for construction of display. Trays were damaged in shipping and had to be taped together to contain product.

RECOMMENDED



Each tier has been designed to handle the weight of the merchandise and allows the display to be shopped, since each tier isn't resting on the product below.



No carton marking icons were used on shroud and/or master carton to indicate Pallet Display enclosed. Displays can start to buckle when too much weight is placed on display unnecessarily.



Using carton marking icons on the shipping shroud or master carton communicates to DC associates to be careful with what is loaded on this floor display for shipment to stores.

**Big Lots standard for pallets is: 4-way Pallet GMA B
48" x 40" (121.92 cm x 101.6 cm)**

FLOOR DISPLAY WITH SHROUD

Visual of Shroud covering the floor display for shipping.
NOTE: Carton Marking Icons placed on all four sides of shroud/display.



If Shroud covers the pallet, allow for cut-aways at base of shroud for the floor jack.



FLOOR DISPLAYS

Master Carton Marking Icons

This icon communicates Floor Display to the DC associate. DC associate will then avoid stacking other heavy boxes onto the Floor Display/product when loading our trucks to avoid damaging the Floor Display.

**FLOOR
DISPLAY**

**FLOOR DISPLAY - DO NOT STACK HEAVY
PRODUCT ON TOP OF CARTON**

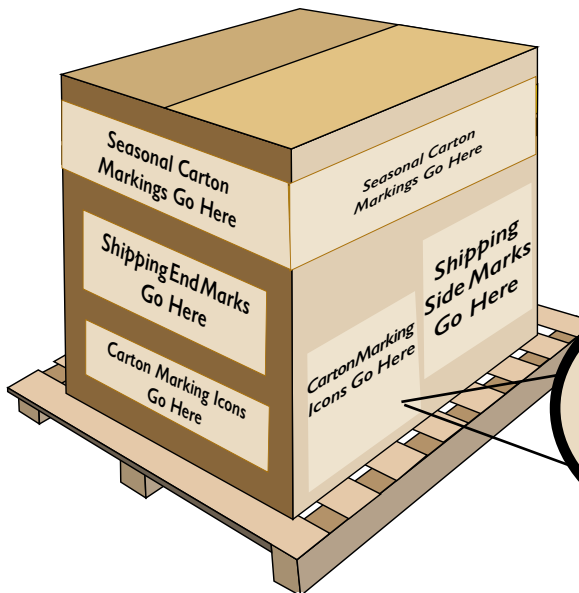

Example Only

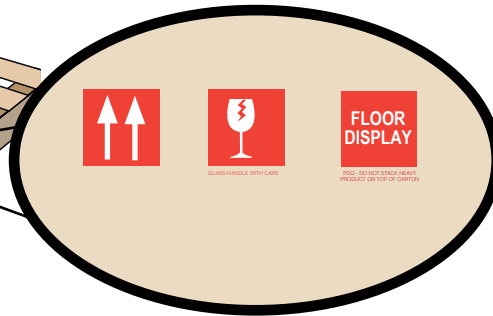

NOTE: Displays with cardboard feet are NOT ALLOWED.



NOTE: Cartons containing Floor Displays, but do not display required icon(s) are likely to be crushed during shipping.

NOTE: Carton marking icons are required to be placed on at least four different sides of the Master Shipping Carton. If the master shipping carton contains a casepack of one then the carton marking icons are also required on at least four different sides of the box. See [Carton Marking Icon Sizing Chart](#) (page 9) for appropriate size carton marking icon(s).

- Required Carton Markings Document and icons can be found on our website at:
<http://www.biglots.com/corporate/vendor-relations/vendor-routing-and-compliance>

NOTE: For questions on Carton Markings contact vendorcompliance@biglots.com

Please include a copy of this sheet and list the following information when submitting white pack out samples for approval:

Article#:

Case Pack per Article:

Dimensions of Pallet (in inches):

Height:

Depth:

Width:

Dimensions of Display (in inches):

Height:

Depth:

Width:

Weight of Display:



————— **REQUIRED TRANSIT TESTING** —————



1. Purpose

The purpose of this document is to establish standardized package performance test methods and procedures to ensure that Side Kick and Pallet Displays are designed, tested and evaluated prior to shipping to withstand normal shipping and handling hazards. These tests are intended to help determine if the current and future levels of packaging provide adequate protection through the distribution system to retail stores. **All displays shall be designed to “Pass” its specified test protocol noted below.**

2. Overview

Side Kick and Pallet Displays will be subjected to drops, vibration and compression testing to evaluate the performance of the entire packaging system (primary, secondary, tertiary and protective packaging).

3. General requirements

- Side Kick displays to be tested per **ISTA 2A** test protocol.
- Pallet displays to be tested per **ISTA 3E** test protocol.
- Testing to be completed by an ISTA certified lab. Please refer to www.ista.org to locate a certified lab in your area. **Please provide the Big Lots Package Testing Criteria and this Transit Testing Section of our Corrugate Display Standards to your ISTA certified facility.**
- All “passed” test reports shall be submitted and approved by Big Lots personnel prior to mass production of Side Kick or pallet display packaging materials. Any and all exceptions must be approved by Big Lots personnel.
- Submit test report, including pre-inspection photos (in secondary package of all 6 sides) and post-inspection (Includes photos of display removed from secondary packaging and photos of all 6 sides of the display) photos to: Big Lots Packaging at: (packaging@biglots.com)
- Test report shall be valid for a 1 year time period. Any changes in materials, package size, design structure shall require new testing and validation. If after a 1 year period, testing may be omitted if no changes in materials, package size, or design structure. Vendors shall provide a letter to Big Lots Packaging, outlining that no changes were made.

4. Acceptance Criteria

See separate “Big Lots – Display Acceptance Criteria” document for additional details

5. Test Report Format

Test report format to include, but not limited to, the following:

- Test sample size and description
 - Size, weights, etc
- Pre-inspection photos (in secondary packaging, photos of all 6 sides)
- Documented test procedures and results
 - To include images of test setup and procedures
- Post inspection photos (Includes photos of display removed from secondary packaging and photos of all 6 sides of display)
- Any noted damage during any of the test series procedures
 - test method / standard

If item or display is damaged during test sequences please proceed in finishing the test in its entirety.

6. Sample size requirements

For all tests, a minimum sample size of one side kick display or pallet displays will be required. Perform each series of tests on each individual side kick display or pallet display.

Packages shall be over packed with protective materials for delivery to test lab facility, so that the test package does not endure rigors of transportation shipment before it gets to the lab.





This may include over boxing the display with protective foam.

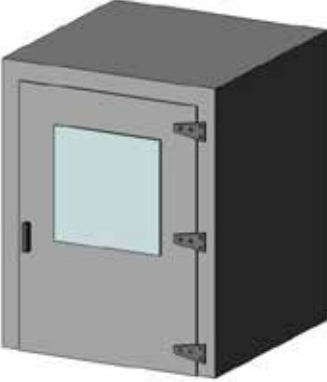

7. Pre-inspection

Inspect the product and packaging for damage, abrasion, punctures, etc prior to beginning the first test sequence. Photos shall be taken at pre-inspection to note and record current package condition and any noted damage prior to testing.

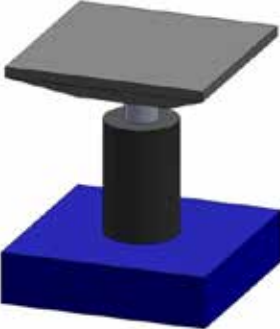
8. Test Overview

| Summary of Testing | | | |
|--|----------------|---|--|
| Display Type | Test Procedure | Test Description | Summary |
| Side Kicks | ISTA 2A | Packaged-Products 150 lbs (68kg) or Less | Atmospheric conditioning, compression, random vibration, and shock testing |
| Floor & Pallet Displays Includes Stackable PDQs | ISTA 3E | Unitized Loads of Same Product | Atmospheric conditioning, compression, random vibration, shock testing |

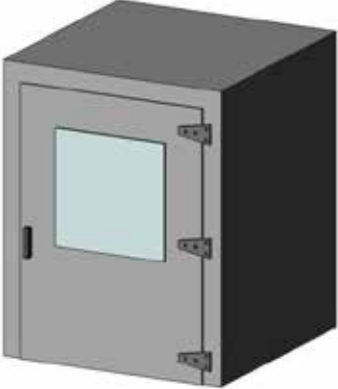
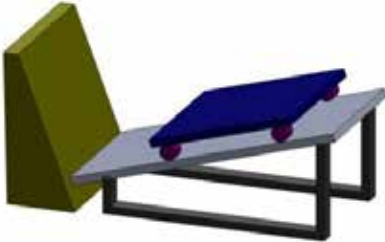
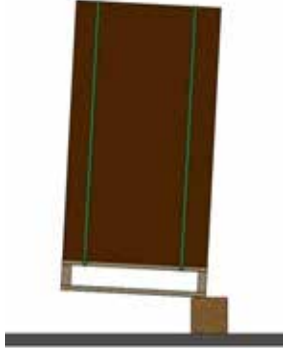
| Side Kicks – ISTA 2A Summary | |
|---|---|
|  <p>100 F (38 C) Preconditioning for 6 hours Conditioning for 24 hours</p> |  |
| Atmospheric Conditioning | Compression |
|  |  |
| Random Vibration | Shock Testing |

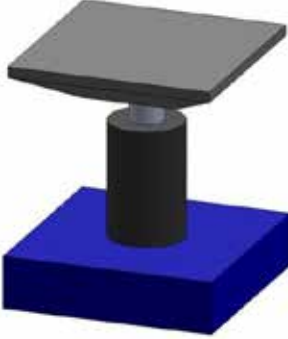
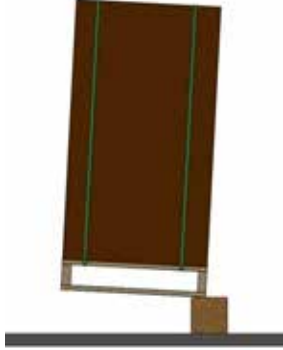
| Pallet Displays – ISTA 3E Summary | | |
|--|---|--|
|  |  |  |
| Atmospheric Conditioning 100°F (38°C) | Shock – Horizontal Impact | Shock – Rotational Edge Drop |
|  |  |  |
| Compression | Random Vibration | Shock – Rotational Edge Drop |



Big Lots! Package Testing Acceptance Criteria

Purpose:

- The function of retail displays is to present the product and increase sales and velocity, while maintaining its structural integrity and aesthetic appeal throughout the life of the display
- **The purpose of this document is to give some definition to types of acceptable and unacceptable damage – either to the display packaging or the product - and to make the review process more consistent and less subjective.**
- After testing, the reviewers will ask themselves “is this result acceptable or unacceptable?” They will need to determine what will be considered “damage” and result in a FAILED test, which would then need to be enhanced and retested.
- Extensive damage to the product, primary packaging and/or display packaging has a negative effect on the sale of goods and results in increased store labor and potential loss of sales

AFTER A PASSED TRANSIT TEST IS RECEIVED DO NOT MODIFY PACKAGING WITHOUT WRITTEN CONSENT FROM BIG LOTS PACKAGING TEAM.

Product damage

- Product damage can be any condition, which causes the product to not meet its performance specifications. It can include both structural and cosmetic damage which makes the product unacceptable to the customer and would result in a 1) lost sales or 2) store markdown
3) discounted product 4) Store labor cost to relocate product.

Product(s) must not be missing, torn, dented, scratched, cracked, broken, crushed, bent, wrinkled, wet, or have smeared artwork as a result of testing

- Examples of general acceptance criteria are as follows:
 - The product functions per its original intention
 - Product is damage-free; no structural damage including no detached, loose, fractured or deformed materials
 - Product cosmetic areas are not degraded beyond manufacturing or final acceptance criteria. Cosmetic damage is defined as non-structural defect that does not affect the function or safety of the product that would be also be deemed unacceptable by the customer
- Examples of general product failure criteria are as follows:
 - Failure of the product to perform as originally intended
 - Damage that negatively impacts the sale of the item (chipped and/or scuffed paint, dents, scratches, tears, etc)

Secondary and Protective Packaging

- The purpose of the package is to absorb, distribute or modify the energy transmitted by the distribution environment and to protect and preserve the product in its original, undamaged condition.

Packaging must support the product and not show damage to the product during or after completion of each test identified in the test procedure

- Some package damage and degradation to the secondary and/or protective packaging is expected and acceptable
- UNACCEPTABLE package degradation may be defined, but not limited to:
 - ANY structural or cosmetic damage that would cause the customer to believe the product inside is damaged, even if the product is not damaged.



- UNACCEPTABLE package degradation may be defined, but not limited to:
 - ANY structural or cosmetic damage that would cause the customer to believe the product inside is damaged, even if the product is not
 - Cosmetic wear that would result in a markdown to the product
 - Any change in package condition, including fractured or deformed materials that may result in product damage or permanent displacement of the product and accessories from their intended position
 - Edge ruptures to the shipper to the extent that it can no longer contain the product, support the product's weight, or facilitate the movement of the packaging in the distribution environment
 - Excessive puncture, tearing or breaking of retail display
 - Leaking of liquids or granular product
 - Severe damage to packaging materials is not acceptable

Display Packaging - Side Kick displays criteria

Shipper glue joint seams shall remain sealed (glue joint failure in shipper box)

Shipper shall remain sealed and in-tact – either by its original tape or adhesive closure

Method or apparatus for hanging display has not been damaged or deteriorated beyond use in the store or missing from display shipper

- Examples of potential FAILURES:



| | |
|--|---|
| | |
| <p>Product loose and displaced from peg</p> | <p>Product loose within Side Kick and displaced from peg hooks</p> |
| | |
| <p>Product peg hooks are not to be deformed, broken, missing or punctured through display shipper (Peg Hook Missing shown)</p> | <p>Peg hooks sag, crack or break due to weight of product and lack of protective insert</p> |

| | |
|--|--|
| | |
| <p>Tray front lip dented and creased – likely from weight of product and lack of support structure</p> | <p>Damage, wrinkling to main facing of side kick display</p> |
| | |
| <p>Display construction deteriorated</p> | <p>Ruptured shipper shown</p> |

Display Packaging - Pallet display damage examples

Void fill materials are not damaged or compressed beyond means of providing adequate protection
 There shall be no broken or missing parts that compromise the structural integrity of a pallet, upon completion of transit testing
 To secure display to a pallet, there shall be no missing bands, shrink wrap, or clips

| | | |
|--|--|--|
| | | |
| <p>Layered display tiers shall not deform, sag, or detach from adjacent layered trays (due to adhesive failure, lock tab failure or other)</p> | <p>Leaning displays – top heavy – presents safety concerns</p> | <p>Leaning displays – top heavy – presents safety concerns</p> |

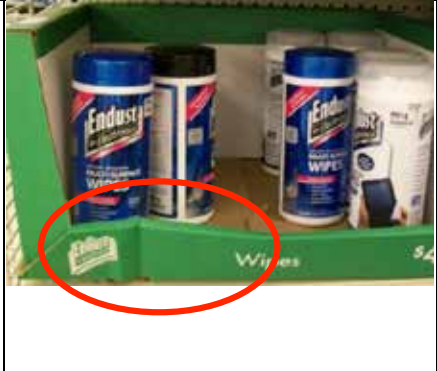
| | |
|---|---|
|  |  |
| <p>Products loose within display tray = greater labor at store level</p> | <p>Display shall remain on pallet (no shifting of display or trays from pallet base)</p> |
|  |  |
| <p>Damage to internal supports & display structure damage – will severely impact the life and image of the display!</p> | <p>Internal structure & supports damaged such that it affects the performance and safety of the display</p> |
|  |  |
| <p>Front facing of display scratched, dented, damaged = lowers perception of product/ package by customer</p> | <p>Display tray facing dented, creased</p> |

****Overall Acceptance Criteria is dependent on the degree (severity) and location of the damage on the display. Any and all exceptions are to be approved by Big Lots - Deanna Taylor**